



Table of Contents

Introduction

[Use the Online Documentation](#)
[Using The How To Manual](#)
[EnSight Overview](#)

Start EnSight

[Connect Automatically](#)
[Connect Manually](#)
[Command Line Start-up Options](#)
[Use Collaboration](#)

Read and Load Data

[Read Data](#)
[Use ens_checker](#)
[Load Multiple Datasets \(Cases\)](#)
[Load Transient Data](#)
[Use Server of Servers](#)
[Read User Defined](#)
[Do Structured Extraction](#)

Save or Output

[Save or Restore an Archive](#)
[Record and Play Command Files](#)
[Print/Save an Image](#)
[Save Geometric Entities](#)
[Save/Restore Context](#)
[Save Scenario](#)
[Output for Povray](#)

Manipulate Viewing Parameters

[Rotate, Zoom, Translate, Scale](#)
[Set Drawing Mode \(Line, Surface, Hidden Line\)](#)
[Set Global Viewing Parameters](#)
[Set Z Clipping](#)
[Set LookFrom / LookAt](#)
[Set Auxiliary Clipping](#)
[Define and Change Viewports](#)
[Control Lighting Attributes](#)
[Display Remotely](#)
[Save and Restore Viewing Parameters](#)
[Create and Manipulate Frames](#)
[Reset Tools and Viewports](#)
[Use the Color Selector](#)
[Enable Stereo Viewing](#)
[Pick Center of Transformation](#)
[Set Model Axis/Extent Bounds](#)
[Do Viewport Tracking](#)

Manipulate Tools

[Use the Cursor \(Point\) Tool](#)
[Use the Line Tool](#)
[Use the Plane Tool](#)
[Use the Box Tool](#)
[Use the Cylinder Tool](#)
[Use the Sphere Tool](#)

[Use the Cone Tool](#)
[Use the Surface of Revolution Tool](#)
[Use the Selection Tool](#)

Visualize Data

[Introduction to Part Creation](#)
[Create Contours](#)
[Create Isosurfaces](#)
[Create Particle Traces](#)
[Create Clips](#)
[Create Clip Lines](#)
[Create Clip Planes](#)
[Create Box Clips](#)
[Create Quadric Clips](#)
[Create IJK Clips](#)
[Create XYZ Clips](#)
[Create RTZ Clips](#)
[Create Revolution Tool Clips](#)
[Create Revolution of 1D Part Clips](#)
[Create General Quadric Clips](#)
[Create Vector Arrows](#)
[Create Elevated Surfaces](#)
[Create Profile Plots](#)
[Create Developed \(Unrolled\) Surfaces](#)
[Create Subset Parts](#)
[Create Tensor Glyphs](#)
[Display Displacements](#)
[Display Discrete or Experimental Data](#)
[Change Time Steps](#)
[Extract Vortex Cores](#)
[Extract Separation and Attachment Lines](#)
[Extract Shock Surfaces](#)
[Create Material Parts](#)
[Remove Failed Elements](#)
[Do Element Blanking](#)

Create and Manipulate Variables

[Activate Variables](#)
[Create New Variables](#)
[Extract Boundary Layer Variables](#)
[Edit Color Palettes](#)

Query, Probe, Plot

[Get Point, Node, Element, and Part Information](#)
[Probe Interactively](#)
[Query/Plot](#)
[Change Plot Attributes](#)
[Query Datasets](#)

Manipulate Parts

[Change Color](#)
[Copy a Part](#)
[Group Parts](#)
[Merge Parts](#)
[Extract Part Representations](#)

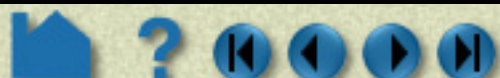



- [Cut Parts](#)
- [Delete a Part](#)
- [Change the Visual Representation](#)
- [Set Attributes](#)
- [Display Labels](#)
- [Set Transparency](#)
- [Select Parts](#)
- [Set Symmetry](#)

Animate

- [Animate Transient Data](#)
- [Create a Flipbook Animation](#)
- [Create a Keyframe Animation](#)
- [Animate Particle Traces](#)

Annotate

- [Create Color Legends](#)
- [Create Lines and Arrows](#)
- [Create Text Annotation](#)
- [Load Custom Logos](#)

Configure EnSight

- [Customize Icon Bars](#)
- [Customize Mouse Button Actions](#)
- [Save GUI Settings](#)
- [Define and Use Macros](#)
- [Set or Modify Preferences](#)
- [Enable User Defined Input Devices](#)
- [Setup For Parallel Computation](#)
- [Setup For Parallel Rendering](#)

Miscellaneous

- [Select Files](#)
- [Use The Feature Detail Editor](#)





[Print/Save an Image](#)
[Activate Variables](#)
[Animate Particle Traces](#)
[Animate Transient Data](#)
[Change Color](#)
[Change Plot Attributes](#)
[Change the Visual Representation](#)
[Change Time Steps](#)
[Command Line Start-up Options](#)
[Connect Automatically](#)
[Connect Manually](#)
[Control Lighting Attributes](#)
[Copy a Part](#)
[Create a Flipbook Animation](#)
[Create a Keyframe Animation](#)
[Create and Manipulate Frames](#)
[Create Box Clips](#)
[Create Clip Lines](#)
[Create Clip Planes](#)
[Create Clips](#)
[Create Color Legends](#)
[Create Contours](#)
[Create Developed \(Unrolled\) Surfaces](#)
[Create Elevated Surfaces](#)
[Create General Quadric Clips](#)
[Create IJK Clips](#)
[Create Isosurfaces](#)
[Create Lines and Arrows](#)
[Create Material Parts](#)
[Create New Variables](#)
[Create Particle Traces](#)
[Create Profile Plots](#)
[Create Quadric Clips](#)
[Create Revolution of 1D Part Clips](#)
[Create Revolution Tool Clips](#)
[Create RTZ Clips](#)
[Create Subset Parts](#)
[Create Tensor Glyphs](#)
[Create Text Annotation](#)
[Create Vector Arrows](#)
[Create XYZ Clips](#)
[Customize Icon Bars](#)
[Customize Mouse Button Actions](#)
[Cut Parts](#)
[Define and Change Viewports](#)
[Define and Use Macros](#)
[Delete a Part](#)
[Display Discrete or Experimental Data](#)
[Display Displacements](#)
[Display Labels](#)
[Display Remotely](#)
[Do Element Blanking](#)
[Do Structured Extraction](#)
[Do Viewport Tracking](#)
[Edit Color Palettes](#)
[Enable Stereo Viewing](#)
[Enable User Defined Input Devices](#)
[EnSight Overview](#)
[Extract Boundary Layer Variables](#)
[Extract Part Representations](#)
[Extract Separation and Attachment Lines](#)
[Extract Shock Surfaces](#)
[Extract Vortex Cores](#)
[Get Point, Node, Element, and Part Information](#)
[Group Parts](#)
[Introduction to Part Creation](#)
[Load Custom Logos](#)
[Load Multiple Datasets \(Cases\)](#)
[Load Transient Data](#)
[Merge Parts](#)
[Output for Povray](#)
[Pick Center of Transformation](#)
[Probe Interactively](#)
[Query Datasets](#)
[Query/Plot](#)
[Read Data](#)
[Read User Defined](#)
[Record and Play Command Files](#)
[Remove Failed Elements](#)
[Reset Tools and Viewports](#)
[Rotate, Zoom, Translate, Scale](#)
[Save and Restore Viewing Parameters](#)
[Save Geometric Entities](#)
[Save GUI Settings](#)
[Save or Restore an Archive](#)
[Save Scenario](#)
[Save/Restore Context](#)
[Select Files](#)
[Select Parts](#)
[Set Attributes](#)
[Set Auxiliary Clipping](#)
[Set Drawing Mode \(Line, Surface, Hidden Line\)](#)
[Set Global Viewing Parameters](#)
[Set LookFrom / LookAt](#)
[Set Model Axis/Extent Bounds](#)
[Set or Modify Preferences](#)
[Set Symmetry](#)
[Set Transparency](#)
[Set Z Clipping](#)
[Setup For Parallel Computation](#)
[Setup For Parallel Rendering](#)
[Use Collaboration](#)
[Use ens_checker](#)
[Use Server of Servers](#)
[Use the Box Tool](#)
[Use the Color Selector](#)
[Use the Cone Tool](#)
[Use the Cursor \(Point\) Tool](#)
[Use the Cylinder Tool](#)
[Use The Feature Detail Editor](#)
[Use the Line Tool](#)
[Use the Online Documentation](#)
[Use the Plane Tool](#)
[Use the Selection Tool](#)
[Use the Sphere Tool](#)
[Use the Surface of Revolution Tool](#)
[Using The How To Manual](#)

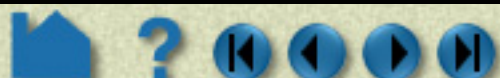



INTRODUCTION

The EnSight online documentation consists of:

Installation Guide Consists of a .pdf file in the doc directory (as well as being available for easy reading from the web install page). Also goes out as hardcopy with an EnSight distribution CD.

Getting Started Manual The Getting Started Manual contains basic Graphical User Interface overview information and several tutorials. This manual is not cross-referenced with any of the other manuals.

How To Manual The How To documentation consists of relatively short articles that describe how to perform a specific operation in EnSight, such as change the color of an object or create an isosurface. Step-by-step instructions and pictures of relevant dialogs are included. In addition, each How To article typically contains numerous hyperlinks (colored **blue**) to other related articles (and relevant sections of the User Manual).

Note that, although the entries in the How To table of contents and index are not colored blue, you can still click on an entry and jump to the appropriate document.

[How To Use the How To Manual](#)
[How To Table of Contents](#)
[How To Index](#)

User Manual The User Manual is a more traditional document providing a detailed reference for EnSight. The User Manual contains blue hyperlinks as well. Both the User Manual table of contents and index entries are hotlinked as well as cross-reference entries within chapters (which typically start with "[See Section ...](#)" or "[See How To ...](#)").

[User Manual Table of Contents](#)
[User Manual Index](#)

Command Language Manual The Command Language Reference Manual documents command language used within EnSight. This manual contains some cross-references to the How To and User Manuals, but cross-referencing from them back is extremely minimal.

WHERE TO START?

If you are new to EnSight you should read the [EnSight Overview](#) article. [Chapter 1](#) and [Chapter 5](#) in the User Manual also provide overview information. The [Introduction to Part Creation](#) provides fundamental information on EnSight's *part* concept.

ACROBAT READER

The EnSight online documentation uses the Acrobat® Reader software from Adobe Systems, Inc. Acrobat Reader provides much the same functionality as a World Wide Web browser while providing greater control over document content quality. See [How To Use the How To Manual](#) for more information on Acrobat Reader.



HOW TO PRINT THE DOCUMENTATION

Printing Topics From The Acrobat Reader

You can easily print any topic in the How To manual or any pages from the other documentation from within Acrobat. The documents have been optimized for screen manipulation, but will still produce decent hardcopy printouts. To print a topic:

1. Navigate to the topic you want to print.
2. Choose Print... from the File menu of Acrobat Reader.
3. Be sure the Printer Command setting is correct for your environment and then click OK. Your document should print to the selected (or default) printer. If you do not have a printer available on your network or you wish to save the PostScript file to disk, you can do so: click the File button, enter a filename, and click OK.

Printing EnSight Manuals

You can print (all or portions of) the EnSight manuals from provided .pdf files. These files have been print optimized and should produce reasonably high quality hardcopy. They have all been formatted for letter size paper. These files are located in the doc/Manuals directory of the EnSight installation.

`$CEI_HOME/ensight80/doc/Manuals/GettingStarted.pdf`

`$CEI_HOME/ensight80/doc/Manuals/HowTo.pdf`

`$CEI_HOME/ensight80/doc/Manuals/UserManual.pdf`

`$CEI_HOME/ensight80/doc/Manuals/CLmanual.pdf`

You can open these manuals in Acrobat and print any or all pages, or send them to an outside source for printing.

CONTACTING CEI

If you have questions or problems, please contact CEI:

Computational Engineering International, Inc.
2166 N. Salem Street, Suite 101
Apex, NC 27523 USA

Email: support@ensight.com
Hotline: 800-551-4448 (U.S.)
919-363-0883 (Non-U.S.)

Phone: 919-363-0883
FAX: 919-363-0833

WWW: <http://www.ceintl.com> or <http://www.ensight.com>



Using The How To Manual

INTRODUCTION

The “How To” documentation provides quick access to various topics of interest. The topics provide basic and some advanced usage information about a specific tool or feature of EnSight. Each topic will provide links to the appropriate section of the EnSight User Manual as well as links to other applicable How To articles.

Topics typically contain the following sections:

Introduction	Introduction to the topic
Basic Operation	Quick steps for simple usage
Advanced Usage	Detailed information on topic
Other Notes	Other items of interest
See Also	Links to related topics and documentation

(See below for how to quickly jump to a specific section.)

The header and footer of each article page provides simple navigation controls:

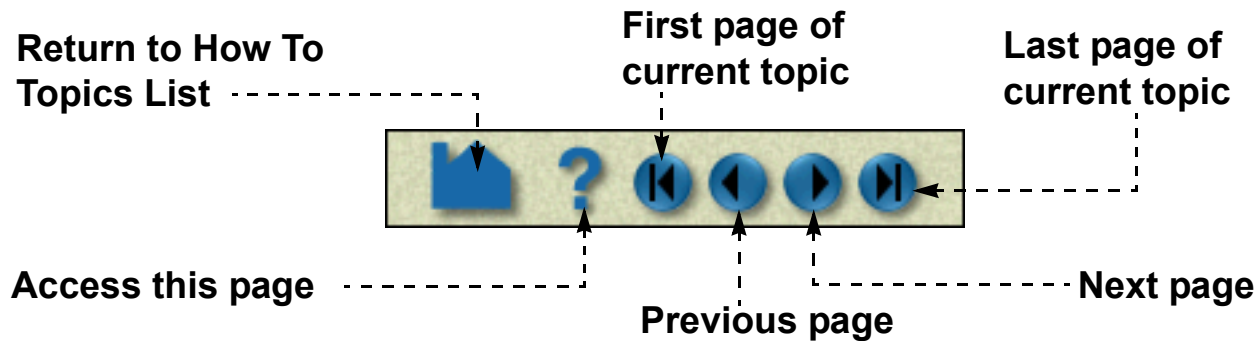

In addition, links to other documents are displayed as **highlighted text**. Note that all links and navigation controls (except index and table of contents) are colored blue.

ACROBAT READER

The EnSight online documentation uses the Acrobat® Reader software from Adobe Systems, Inc. Acrobat Reader provides much the same functionality as a World Wide Web browser while providing greater control over document content quality. The user interface is very simple and provides intuitive navigation controls. Keep in mind that the pages were designed to be viewed at 100% magnification. Although you can use other magnification settings, the quality of the dialog images may be degraded.

The Acrobat Reader toolbar provides quick access to various display options and navigation controls.

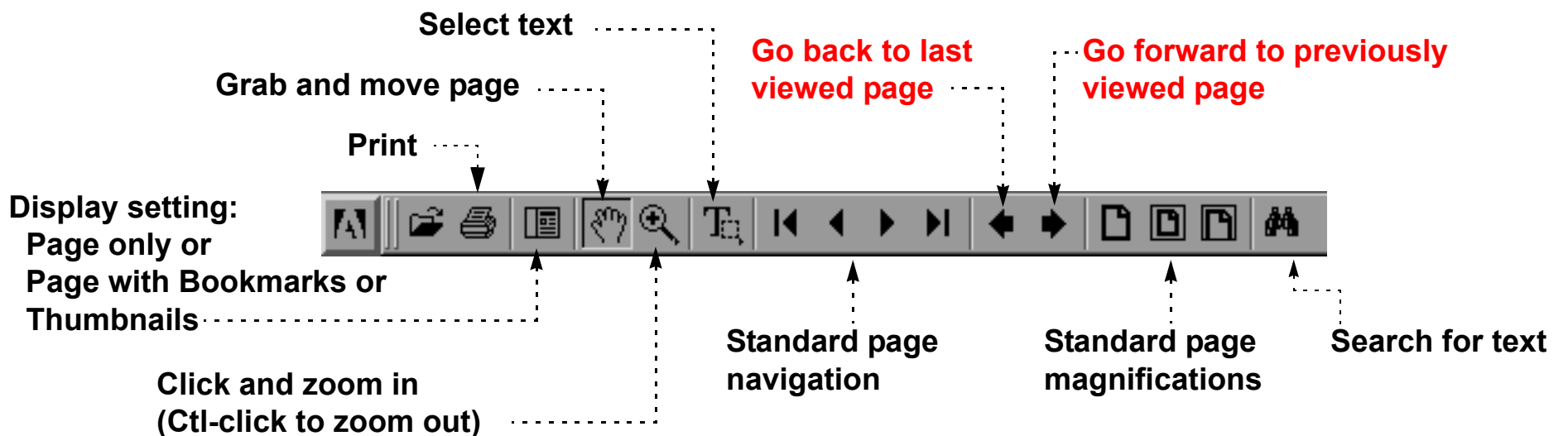

The “Go back/forward” buttons are particularly useful – they operate somewhat like the “Back” and “Forward” buttons on standard Web browsers. If your previously viewed page was in a different document, Acrobat will automatically reload the appropriate file and jump to the correct page. Note that Acrobat also considers a change of view (e.g. scrolling) or magnification as an event to remember in the back/forward list.

For additional information on Acrobat Reader, you can load the online help by selecting “Reader Online Guide” from the Help menu.



Each How To topic provides a set of *bookmarks* that match the standard section titles. You can quickly navigate to one of these sections by using the bookmark list in the left column of the Acrobat user interface:

Be sure **Bookmark/Thumbnails display is selected** -----

Be sure **Bookmarks tab is selected** -----

Click the **turndown to hide or reveal subsections** -----

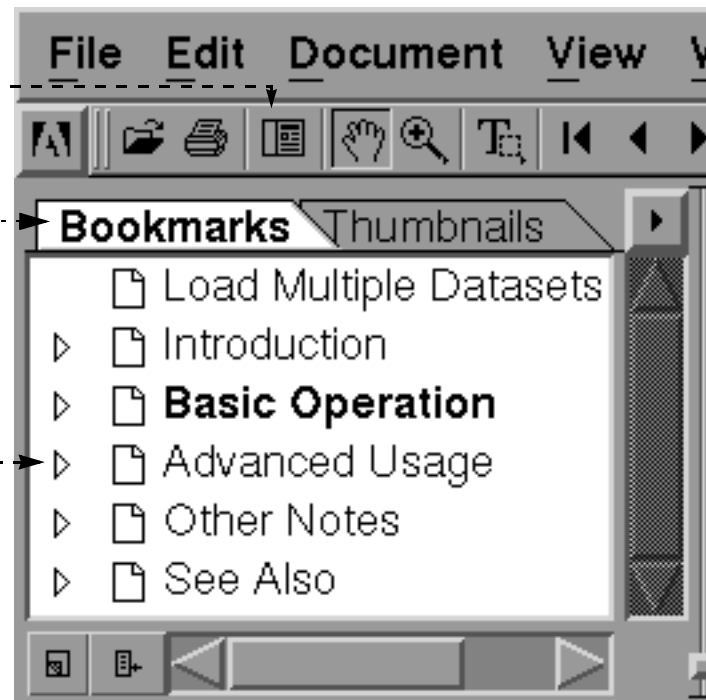

Click on any title to jump to that section

PRINTING

Printing Topics From The Acrobat Reader

You can easily print any topic in the How To manual or pages from the other documentation from within Acrobat. The documents will produce decent hardcopy printouts. To print a topic:

1. Navigate to the topic you want to print.
2. Choose Print... from the File menu of Acrobat Reader.
3. Be sure the Printer Command setting is correct for your environment and then click OK. Your document should print to the selected (or default) printer. If you do not have a printer available on your network or you wish to save the PostScript file to disk, you can do so: click the File button, enter a filename, and click OK.

Printing EnSight Manuals

You can print (all or portions of) the EnSight manuals from provided .pdf files. These files have been print optimized and should produce reasonably high quality hardcopy. They have all been formatted for letter size paper. These files are located in the doc/Manuals directory of the EnSight installation.

```
$CEI_HOME/ensight80/doc/Manuals/GettingStarted.pdf
$CEI_HOME/ensight80/doc/Manuals/HowTo.pdf
$CEI_HOME/ensight80/doc/Manuals/UserManual.pdf
$CEI_HOME/ensight80/doc/Manuals/CLmanual.pdf
```

You can open these manuals in Acrobat and print any or all pages, or send them to an outside source for printing.



ENSIHT OVERVIEW

EnSight is a powerful software package for the postprocessing, visualization, and animation of complex datasets. Although EnSight is designed primarily for use with the results of computational analyses, it can also be used for other types of data.

This document provides a very brief overview of EnSight. Consult [Chapter 1](#) in the User Manual for additional overview information. This article is divided into the following sections:

- [Graphical User Interface](#)
- [Client / Server Architecture](#)
- [EnSight's Parts Concept](#)
- [Online Documentation](#)

Graphical User Interface

The graphical user interface (GUI) of EnSight contains the following major components:

Note: This whole upper level of the GUI is referred to as the "Desktop"

Information Area Button

Click to see information dialog.

Message Area

Quick Interaction Area
Interface controls associated with the current feature selected from the Feature Icon Bar.

Main Menu

Feature Icon Bar

Sets the current feature. Click an icon to open the associated Quick Interaction area.

Main Parts List

All parts from your model as well as created parts (e.g. clips, isosurfaces) are listed here. Click an item to select part(s) to operate on.

Mode Selection Area

Sets the major mode of EnSight (Part, Annot, Plot, VPort, ...) and loads the applicable set of icons into the vertical Mode Icon Bar. Click the button to select the Mode.

Mode Icon Bar

The set of icons associated with the current Mode. Click the icon to access the function. If Tool Tips are on (bottom right of desktop), the icon's function name will be shown when mouse is over the icon. If necessary, use the vertical scroll bar to access the remainder of the icons.

Transformation Control Area

Buttons that control the current transformation operation (e.g. rotate or translate) associated with mouse action in the Graphics Window. Other buttons open dialogs providing detailed transformation control.

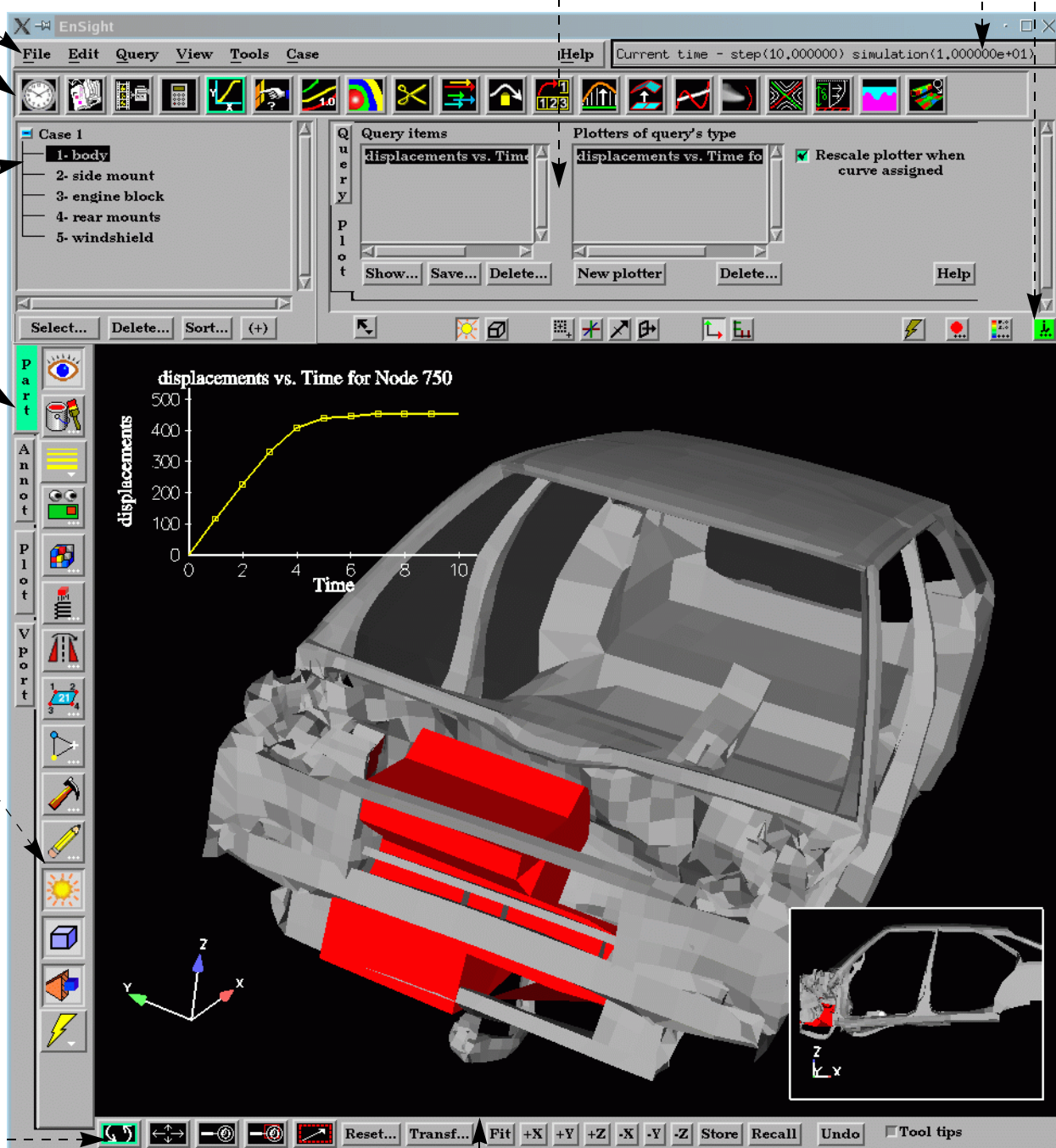

Graphics Window showing inset plot and viewport

[Chapter 5](#) in the User Manual provides additional overview information on the user interface.



Client / Server Architecture

To facilitate the handling of large datasets and efficiently use networked resources, EnSight was designed to distribute the postprocessing workload. Data I/O and all compute intensive functions are performed by a *server* process. The server transmits 3D geometry (and other information) to a *client* running on a graphics workstation. The client handles all user interface interaction and graphic rendering using the workstation's built-in graphics hardware.

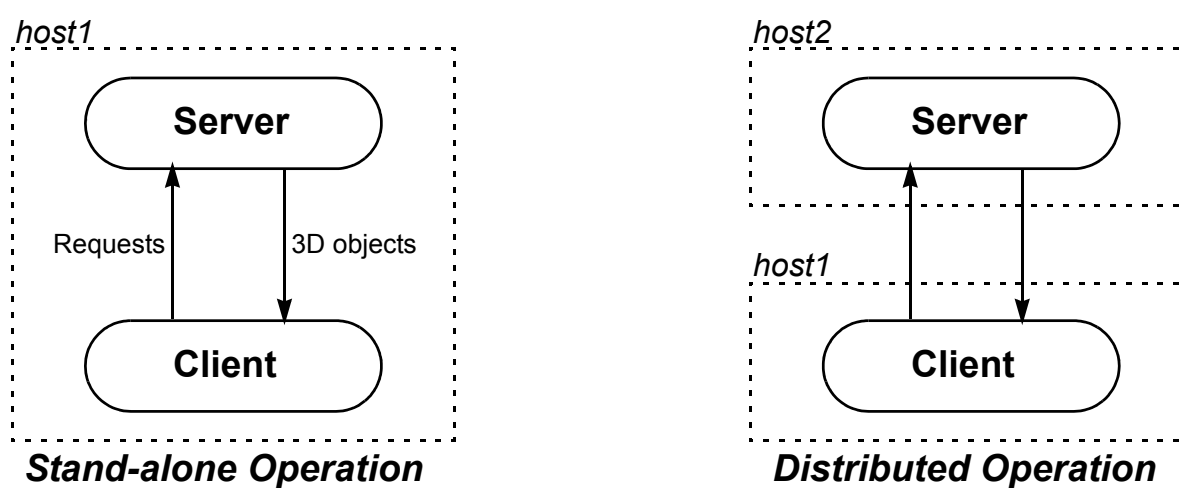

The client and server each run as separate processes on one or more computers. When distributed between a compute server and a graphics workstation, EnSight leverages the strengths of both machines. When both tasks reside on the same machine, a stand-alone capability is achieved. The client-server architecture allows EnSight to be used effectively, even on systems widely separated geographically.

Before EnSight can be used, the client and server must be *connected*. For standalone operation, you simply run the "ensight8" script and the client and server are started and connected for you. For distributed operation (as well as for standalone operation when more control is desired), there are two methods of achieving a connection: a manual connection (described in the Getting Started manual) or an automatic connection (described in [How To Connect Automatically](#)).

EnSight's [cases](#) feature allows you to postprocess multiple datasets simultaneously. Cases is implemented by having a single client connected to multiple servers running on the same or different machines.

EnSight's Parts Concept

One of the central concepts of EnSight is that of the *part*. A part is a named collection of elements (or cells) and associated nodes. The nodes and/or elements may have zero or more *variables* (such as pressure or stress). All components of a part share the same set of attributes (such as color or line width).

Parts are either built during the loading process (based on your computational mesh and associated surfaces) or created during an EnSight session. Parts created during loading are called *model parts*.

All other parts are created during an EnSight session and are called *created* or *derived* parts. Created parts are built using one or more other parts as the *parent parts*. The created parts are said to *depend on* the parent parts. If one or more of the parent parts change, all parts depending on those parent parts are automatically recalculated and redisplayed to reflect the change. As an example, consider the following case. A clipping plane is created through some 3D computational domain and a contour is created on the clipping plane. The contour's parent is the clipping plane, and the clipping plane's parent is the 3D domain. If the 3D domain is changed (e.g. the time step changes), the clipping plane will first be recalculated, followed by the contour. In this way, part coherence is maintained.

One of the major modes of EnSight is Part Mode. Operations in Part Mode (performed by clicking one of the icons in the vertical Mode Icon bar) operate on the parts currently selected in the Main Parts list. See [How To Select Parts](#) for more information.

See the [Introduction to Part Creation](#) for more information on parts.

Online Documentation

Documentation for EnSight is available online. See [How To Use the Online Documentation](#) for more information as well as hyperlinks to the main documents. Online documentation is accessed from the Main Help menu in the user interface. In addition, major dialog windows contain Help buttons that will open a relevant "How To" article.



INTRODUCTION

EnSight is a distributed application with a *client* that manages the user interface and graphics, and a *server* that reads data and performs compute-intensive calculations. The client and server each run as separate processes on one or more computers. Before EnSight can do anything useful, the client process must be connected to the server process. For a standalone operation, you can simply start EnSight with the “ensight8” script and the client and server processes will be started and connected for you. If you desire more control over the standalone operation or want to take advantage of a distributed operation, you have the options described below.

There are two basic types of connection: *manual* and *automatic*. A manual connection is made by starting the client, telling it to listen for a server connection, and then starting the server (and telling it what machine the client is running on). Manual connection is covered in detail in the [How To Connect Manually](#). Automatic connection is covered here.

BASIC OPERATION

The auto-connect mechanism requires that certain conditions exist in your computing environment:

On Unix Systems:

1. You have a valid `.rhosts` file in your home directory on all systems on which you wish to run the EnSight server. The file permission for this file must be such that only the owner (you) has write permission (e.g. `chmod 600 ~/.rhosts`). A `.rhosts` file grants permission for certain commands (e.g. `rsh` or `rlogin`) originating on a remote host to execute on the system containing the `.rhosts` file. For example, the following line grants permission for remote commands from host `clienthost` executed by user `username` to execute on the system containing the `.rhosts` file:

```
clienthost username
```

There should be one line like this for every client host system that you wish to be able issue remote commands from. It is sometimes necessary to add an additional line for each client host of the form `clienthost.domain.com username` (where `domain.com` should be changed to the full Internet domain name of the client host system).

2. You have a `.cshrc` file (even if you are running some other command shell such as `/bin/sh`) in your home directory on the EnSight server host that contains valid settings for `CEI_HOME`, and that your `path` variable includes the `bin` directory of `CEI_HOME`. For example, if your EnSight distribution is installed in `/usr/local/CEI` and you are running EnSight on an SGI system (other architectures use a different library path variable), your `.cshrc` should contain:

```
setenv CEI_HOME /usr/local/CEI
set path = ( $path $CEI_HOME/bin )
```

3. Your `.cshrc` file (or files sourced or executed from there) has no commands that cause output to be written (e.g. `date` or `pwd`). Any output would be interpreted as an EnSight server startup error.
4. You can successfully execute a *remote shell* command from the client host system to the server host system. The name of the remote shell command varies from system to system. While logged on to the client host system, execute one of the following (where `serverhost` is the name of your server host system):

```
rsh serverhost date
remsh serverhost date
```

If successful, the command should print the current date.

If any of these conditions are not met, you will be unable to establish a connection automatically and will have to use the manual connection mechanism. Note that it is not uncommon for system administrators to disable operation of all remote commands for security reasons. Consult your local system administrator for help or more information.



On Windows Systems:

1. You have the EnSight server (ens80sv.exe) installed on the same system as your EnSight client (if you plan to connect to the same system)
---- OR ----
2. You can successfully execute a *remote shell* command from the client host system to the server host system.

Note: While all Windows workstations have the ability to issue RSH (Remote Shell) requests, only systems running Windows Server have the RSH daemon and can respond by executing the EnSight server.

The name of the remote shell command varies from system to system. While logged on to the client host system, execute one of the following (where `serverhost` is the name of your server host system):

```
rsh serverhost date  
remsh serverhost date
```

If successful, the command should print the current date.

If condition 1. or 2. is not met, you will be unable to establish a connection automatically and will have to use the manual connection mechanism. Note that it is not uncommon for system administrators to disable operation of all remote commands for security reasons. Consult your local system administrator for help or more information.





In an initial session, you must provide the connection information to EnSight. Once this is done correctly, you can start future sessions and make the connection automatically. To set up for an automatic connection:

1. Select **File > Connect...** to open the **Connect Server** dialog.

2. Set the **Type** to **Auto**.

3. Enter the **host name** of the system on which you wish to run the EnSight server.

4. Enter the **full path name** of the EnSight server executable:

If the server executable is in your default command search path on the server machine, you do not have to provide the full path name – only the name of the server executable.

5. Enter the **full path name** of the directory from which you wish to start the EnSight server.

This is typically the directory containing your results files. If this field is left blank, the working directory will default to the directory from which the client was started (if both client and server are running on the same system) or your home directory on the server system (if the server is running on a remote machine).

6. If your **login name** on the server host is different from your login name on the client host, enter your server login name here.

7. Click **Connect Server** to initiate the connection process.

See the [Troubleshooting](#) section below if the connection attempt fails.

8. Click **Close** to close the dialog.

You can restore the connection defaults (as stored in `~/.ensight8/ensight.connect.default`) by clicking **Show Server Defaults**.

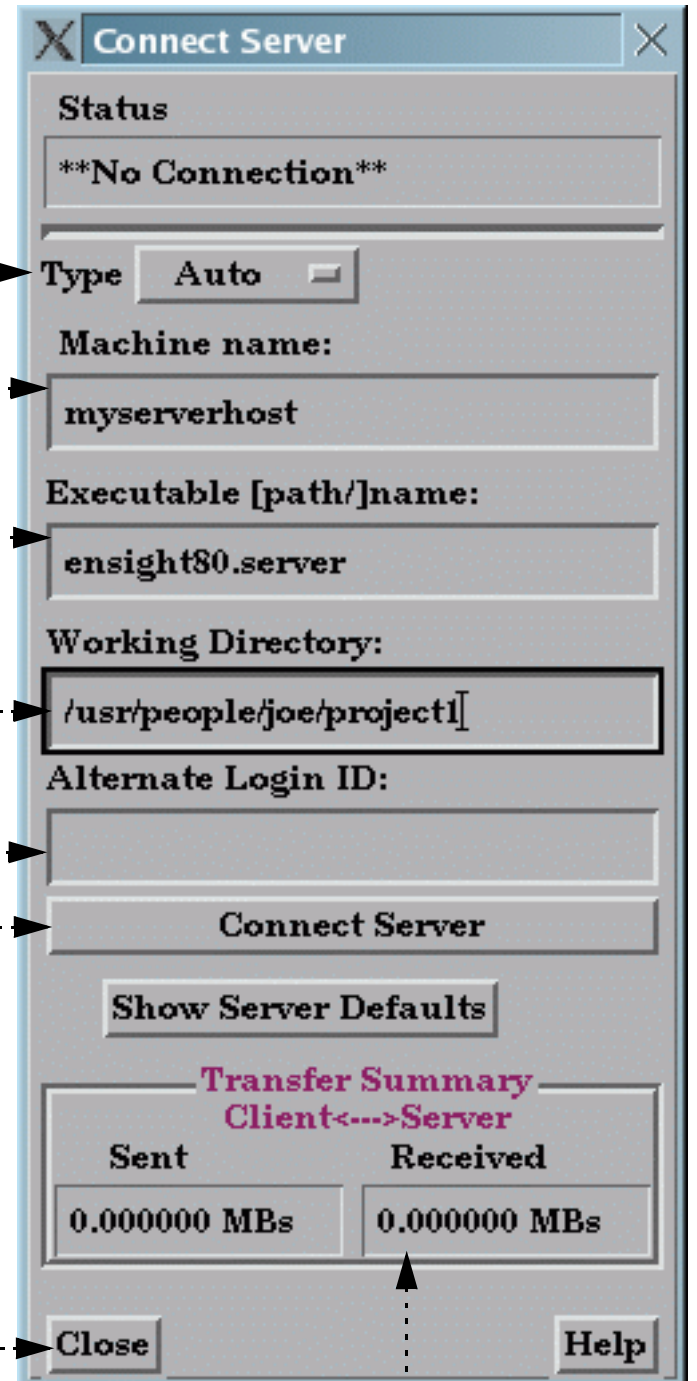

You can open the Connect Server dialog at any time and check the Transfer Summary. This section shows how many bytes have been Sent from the client to the server and how many have been Received in return.

Once an automatic connection has been successfully performed, you can start subsequent sessions of EnSight and connect automatically with the following command:

```
% ensight8
```

(This assumes that your command search path on the client host has been set up to include the client execution directory –e.g. for Unix, `set path = ($CEI_HOME/bin $path)`).



TROUBLESHOOTING

An automatic connection can fail for any of several reasons. Because of the complexity of networking and customized computing environments, we recommend that you consult your local system administrator and/or CEI support if the following remedies fail to resolve the problem.

<i>Problem</i>	<i>Probable Causes</i>	<i>Solutions</i>
For Unix Systems:		
Automatic connection fails or is refused	Server (remote) host name is incorrect for some reason.	Is the server host entered correctly in the Machine Name field? Try running <code>telnet serverhost</code> from the client machine.
	Incorrect or missing <code>.rhosts</code> file in your home directory on the server host.	Follow the instructions on <code>.rhosts</code> files (as described in the Basic Operation section, step 1 above). If you cannot successfully execute a remote command (such <code>rlogin</code> or <code>rsh</code>) from the client host to the server host, you will not be able to connect automatically.
	The user account (<i>i.e.</i> login name) on the client host does not exist on the server host.	Enter your login name on the server host in the Alternate Login ID field.
	The server executable is not found on the server system	Is the entry in the Executable [path/]name field correct? If the server executable is NOT in your default command search path on the server, you must include the full path name to the executable. For example, <code>/usr/local/bin/ensight80/server/ensight8.server</code> .
	Your <code>.cshrc</code> does not contain a valid setting for <code>CEI_HOME</code> .	Add the appropriate line as described in the Basic Operation section, step 2 above.
	Your <code>.cshrc</code> file (or files executed by it) causes output to be written. This is interpreted as a server startup error.	Remove the offending commands from your <code>.cshrc</code> file. As a test, do the following: <pre>% cd % mv .cshrc .cshrc-SAVE</pre> <p>Create a new <code>.cshrc</code> file that contains only the lines to set <code>CEI_HOME</code> and <code>path</code> as described in the Basic Operation section, step 2 above. If that test works, you will need to examine your <code>.cshrc</code> to find and remove the offending lines.</p>
For Windows Systems:		
Automatic connection fails or is refused (trying to connect to same host system)	Server not installed or not executable.	You should be able to locate the server executable (<code>ens6sv.exe</code>) using Windows Explorer. Double click on it and see if a console window opens with "This is EnSight Server 8.0" etc. If this doesn't happen, refer to "Troubleshooting the Installation" in the Getting Started Manual.
	Path to the server is incorrect	If using the EnSight Connect dialog, check that the correct path is specified in the "default path" field. If running from the <code>ensight8</code> command, first ensure that your <code>PATH</code> environment variable contains the paths for the <code>ensight8</code> "client" and "server" directories. You can check and correct the value of <code>PATH</code> in the Start >Settings >ControlPanel >System_Environment dialog.
	Incorrect hostname entered in the "Machine Name" field of the Connect dialog.	Make sure that the hostname is correct, including the case of all letters. The ONLY way to confidently see the hostname (in the correct case) from Windows is to open a Command Prompt window and type: <pre>> ipconfig /all</pre> <p>The Host Name will be one of the first things listed.</p>
Automatic connection fails or is refused (trying to connect to a remote server)	Same causes as for a Unix system	See " For Unix Systems " portion of this table above.



OTHER NOTES

The automatic connection information is stored in the file `~/.ensight8/ensight.connect.default`. The information contained in this file is loaded to the text fields in the Connect Server dialog when it is opened. If required, the file can be edited with any text editor.

By default, the connection between the client and server uses a standard TCP/IP socket mechanism. However, if an automatic connection is being made and EnSight determines that the server will be running on the same machine as the client, it will use a different connection mechanism (known as *named pipes*). This mechanism results in much faster communications between the client and server (from 2 to 5 times speedup). Automatic connection should therefore always be used when running both client and server on the same machine.

SEE ALSO

Chapter 2 of the Getting Started manual.

[How To Connect Manually](#)



Connect Manually

INTRODUCTION

EnSight is a distributed application with a *client* that manages the user interface and graphics, and a *server* that reads data and performs compute-intensive calculations. The client and server each run as separate processes on one or more computers. Before EnSight can do anything useful, the client process must be connected to the server process. For a standalone operation, you can simply start EnSight with the “ensight8” script (or icon, if on a windows or Mac) and the client and server processes will be started and connected for you. If you desire more control over the standalone operation or want to take advantage of a distributed operation, you have the options described below.

There are two basic types of connection: *manual* and *automatic*. A manual connection is made by starting the client, telling it to listen for a server connection, and then starting the server (and telling it what machine the client is running on). Manual connection is covered here. Automatic connection is covered in [How To Connect Automatically](#).

BASIC OPERATION

Necessary Prerequisites

EnSight must have been installed, the `CEI_HOME` and other `ENSIGHT8` environment variables setup, and the command search path set properly. If you successfully performed the installation verification as described in the Installation Guide, you have verified that these things are correct.

(See `$CEI_HOME/ensight80/doc/Manuals/Installation.pdf` if you need this manual.)

Starting EnSight for Distributed Use - Manual Connection

Note: In the instructions that follow, `CLIENT_HOST` refers to the system on which the EnSight Client was installed and will be run, and `SERVER_HOST` refers to the system on which the EnSight Server was installed and will be run.

1. Log onto to the client machine (`CLIENT_HOST`).

This can be a machine of any of the types on which EnSight runs (windows, mac, unix or linux machine).

2. Open two windows.

On a non-windows machine these would be shell or terminal windows. On a windows machine these would be Command Prompt windows.

Note: Since the EnSight user interface comes up by default on the right side of the screen or desktop, it is helpful to place these two windows on the left side of the desktop.

3. In the first window, start the EnSight client by using the appropriate script and the `-cm` option.

If the `CLIENT_HOST` machine is

Windows: `ensight8_client -cm` Note the difference (`.` vs `_`)

Non-Windows: `ensight8.client -cm`

The `-cm` option tells the Client to begin listening for a connection from the Server.

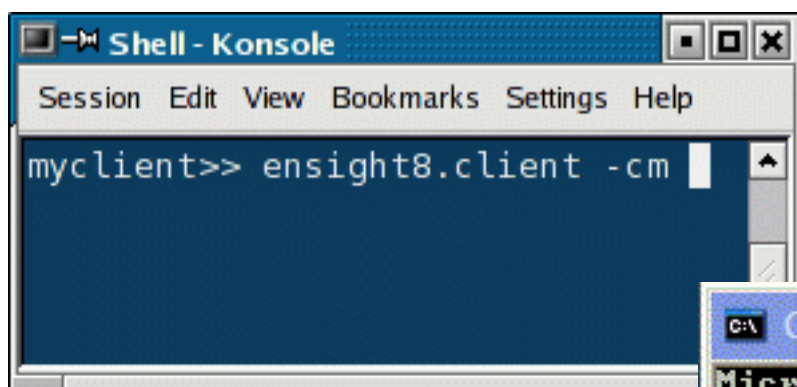

Example in a linux machine shell window.

Example in a windows machine Command Prompt window.

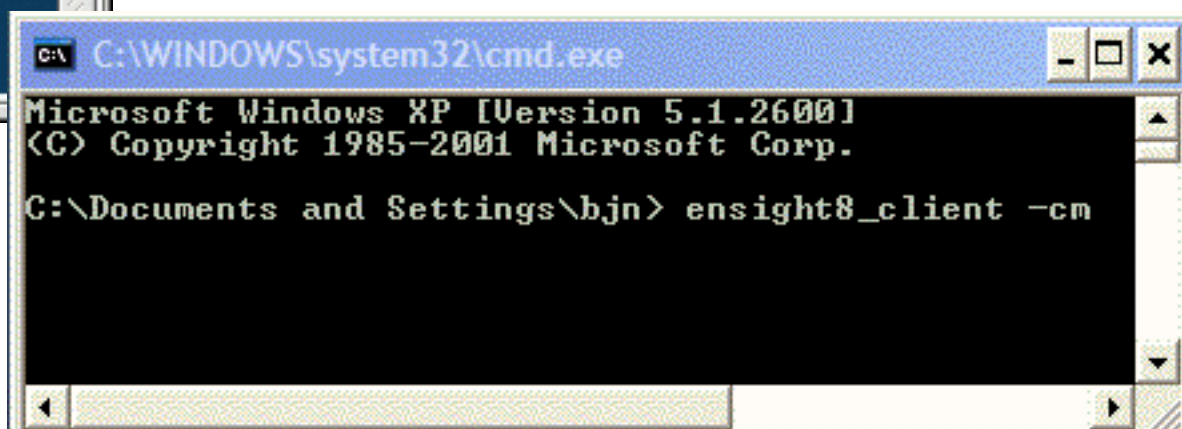



The EnSight Client user interface should now appear on your screen.

4. In the second window, log onto the `SERVER_HOST` machine using telnet (or ssh or equivalent).

This `CLIENT_HOST` can be a machine of any of the types on which EnSight runs (windows, mac, unix or linux machine). It does not have to be of the same type as the `CLIENT_HOST`.

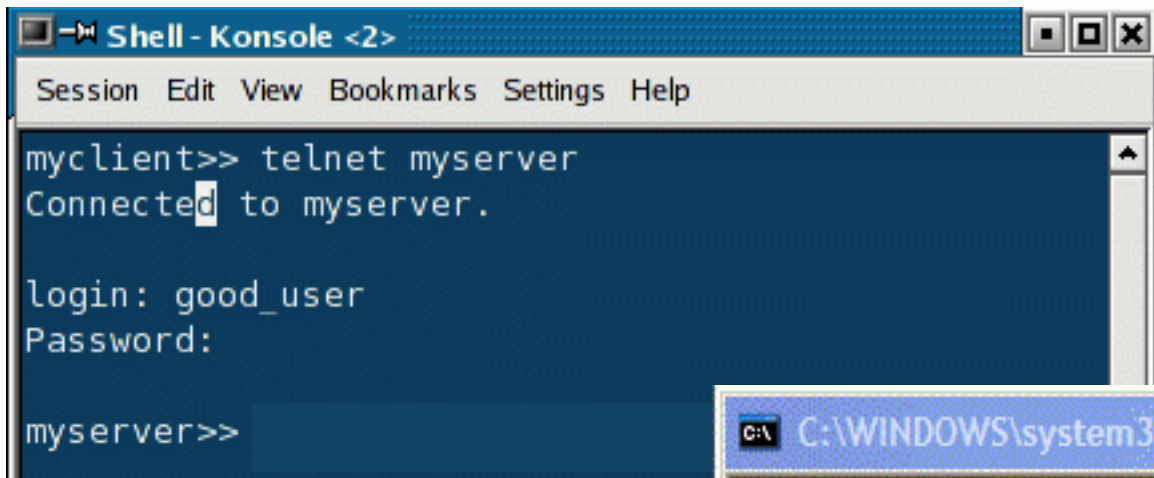

Example of telnetting from a linux machine to a unix machine.

Example of telnetting from a windows machine to a windows machine.

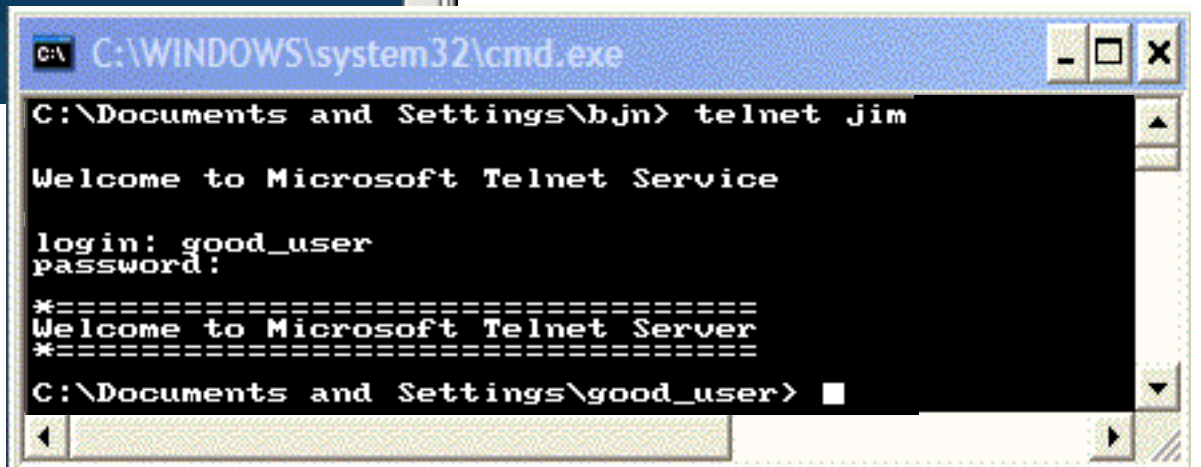

5. Start the ensight server on the `SERVER_HOST` machine, using the appropriate script and the `-c` option.

If the `SERVER_HOST` machine is

Windows: `ensight8_server -c CLIENT_HOST` Note the difference (. vs _)

Non-Windows: `ensight8.server -c CLIENT_HOST`

The `-c CLIENT_HOST` option tells the EnSight Server to connect to the EnSight Client listening on `CLIENT_HOST`.

Example if telnetted into a `SERVER_HOST` which is a windows machine

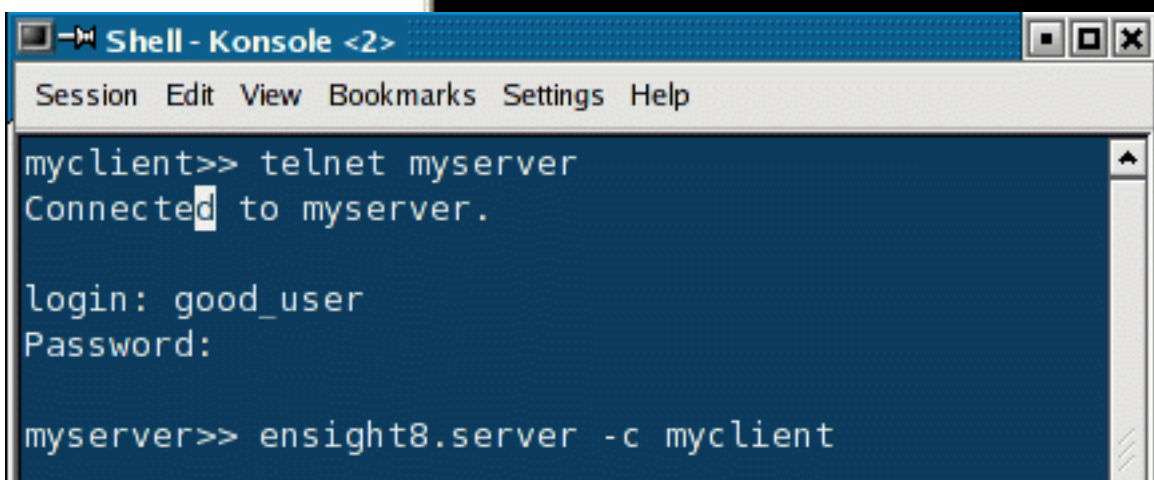
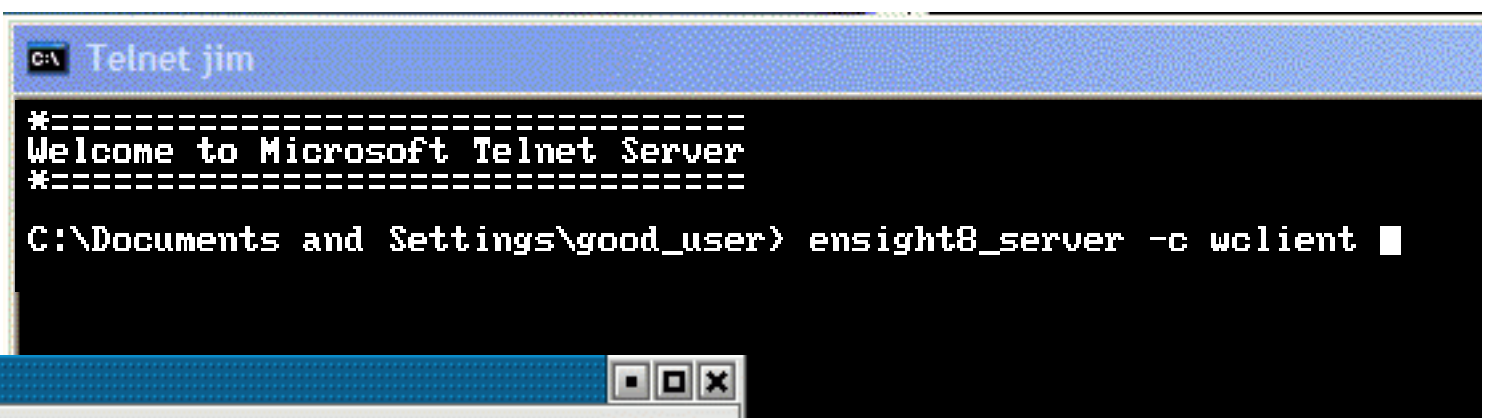

Example if telnetted into a `SERVER_HOST` which is a linux machine.

The Server should now make the connection. To see if the connection is successful, you can click on the Information button on the Desktop. You should see "Connection accepted" in the EnSight Message Window which comes up. Licensing information should also appear in the Graphics Window. If the connection failed, please consult Troubleshooting the Connection in the Installation Guide before contacting CEI support.



TROUBLESHOOTING

An manual connection can fail for any of several reasons. Because of the complexity of networking and customized computing environments, we recommend that you consult your local system administrator and/or CEI support if the following remedies fail to resolve the problem.

<i>Problem</i>	<i>Probable Causes</i>	<i>Solutions</i>
For Unix Systems:		
EnSight client does not start in step 3.	EnSight is not properly installed on the <i>CLIENT_HOST</i>	Verify the installation on the <i>CLIENT_HOST</i> as described in the Installation Guide. Making sure that the proper environment variables and command path have been set.
Unable to telnet into the <i>SERVER_HOST</i> machine in step 4.	Telnet service not allowed or not running on the <i>SERVER_HOST</i> machine.	Get system administration help to be able to perform this operation. It may be that your site requires the use of ssh or some other equivalent.
EnSight server does not start in step 5.	EnSight is not properly installed on the <i>SERVER_HOST</i>	Verify the installation on the <i>SERVER_HOST</i> as described in the Installation Guide. Making sure that the proper environment variables and command path have been set.

OTHER NOTES

Connecting to SOS instead of a regular server

To connect to a SOS (Server of Servers) instead of a regular server, you simply need to change step 5. to be:

5. Start the ensight server of server (SOS) on the *SERVER_HOST* machine, using the appropriate script and the -c option.

If the *SERVER_HOST* machine is

Windows: `ensight8_sos -c CLIENT_HOST` Note the difference (. vs _)

Non-Windows: `ensight8.sos -c CLIENT_HOST`

SEE ALSO

Chapter 2 of the Getting Started Manual

[How To Connect Automatically](#)



INTRODUCTION

There are a number of options that can be included on the command line when starting EnSight. The following tables indicate the commands that can be issued for the EnSight script (ensight8), the EnSight client (ensight8.client), the EnSight server (ensight8.server), or the EnSight server-of-servers (ensight8.sos). To see the most current listing for any of these, issue one or more of the following:

```
ensight8 -help
ensight8.client -help
ensight8.server -help
ensight8.sos -help
```

BASIC USAGE

ensight8 [options]

or

ensight8.client [options]

Section 1. EnSight Startup/Client-Server Options

-ar <f>	Restore from specified archive file "f"
-c <host>	Do an auto connection to machine named "host". EnSight server will run on "host"
-case <f>	Read EnSight casefile name "f" and display part loader
-cm	Do a manual connection of server
-collab_port <#>	Specify the port for collaboration socket communication.
-ctx <f>	Applies context file "f" as soon as connection is made
-custom	Force the license manager to look for a custom token
-delay_refresh	Graphics window is not updated during command file playback, until finished
-extcfd	Extended CFD variables automatically placed in variable list
-externalcmdport	Specify the port on which to receive external commands. See -externalcmds.
-externalcmds	Has EnSight start listening for a connection on port 1104 (or the port specified with the -externalcmdport) for an external command stream. Once connected, all commands must then come from the external source - as the GUI commands will be ignored.
-gold	Force the license manager to look for a gold token
-localhostname <host>	Host name to force server(s) to use to connect to client
-no_delay_refresh	Graphics window is updated during command file playback, until finished
-p <f>	Plays playfile "f" as soon as connection is made
-ports #	Allows user specification of socket communication port. (passed on to server or sos)
-prdist #	Specify a parallel rendering distribution config file.
-rsh <cmd>	Remote shell program to use for automatic connection. (passed on to server or sos)
-security [#]	Forces a handshake between the client and server using the # provided or a random number
-sos	Set up to connect to the Server-of-Servers (ensight8.sos) instead of normal server.
-soshostname <host>	Host name to force server(s) to use to connect to Server-of-Servers
-standard	Force the license manager to look for a standard token
-timeout <#>	Number of seconds to wait for server connection; default = 60, infinite = -1
-token_try_again <#>	If can't obtain a license token, try again in # minutes. where # is a float value. If neither -token_wait_for nor -token_wait_until is specified, will try for 1 hour.
-token_wait_for #	If can't obtain a license token, try again for # minutes, where # is a float value. If -token_try_again is not specified, sets -token_try_again to 10. Supersedes -token_wait_until.
-token_wait_until #	If can't obtain a license token, try again until the time is hour:minute. If -token_try_again is not specified, sets -token_try_again to 10.
-v	Prints out EnSight's version number. (Does not start EnSight)
-version	Prints out EnSight's version number. (Does not start EnSight)

Section 2. EnSight Client GUI Options

-ff	Use the default EnSight fixed font
-----	------------------------------------



-hc <c>	Current Selection Highlight Color Name "c"
-iconlblf <#>	Mode panel icon label font size
-largeicons	Uses larger feature icons in EnSight. (default)
-ni	Will use text in place of icons
-sc <c>	Section Label color name "c"
-smallscreen	Sets window attributes based on the screen size of 1024x768
-smallicons	Uses smaller feature icons in EnSight.

Section 3. EnSight Server Specific Options

-gdbg	Print some debugging info for EnSight format geometries (passed from client to server)
-iwd	Ignore the working directory in the ensight.connect.default file
-time	Prints out timing information (passed from client to server)
-readerdbg	Prints user-defined-reader library loading information in shell window upon startup of server (passed from client to server)
-writerdbg	Prints user-defined-writer library loading information in shell window upon startup of server (passed from client to server)
-maxoff	Turns off maxsize checking (passed from client to server)
-scaleg <#>	Provide scale factor to scale geometry by (passed from client to server)
-scalev <#>	Provide scale factor to scale all vectors by (passed from client to server)
-swd <dir>	Set the server working directory

Section 4. Miscellaneous Options

-h, -help, -Z	Prints the usage list
-helvetica	Use Helvetica font instead of the default Times-Roman for annotation text in the graphics window
-inputdbg	Prints user-defined input device information
-nb	No automatic backup recording
-no_file_locking	Turns off file locking (lock()). Some systems don't support this properly
-no_prefs	Do not load saved user preferences (uses all original defaults)
-range10	Use palette ranges which are 10% in from the extremes
-silent	Causes all stdout and stderr messages to be thrown away
-slimtimeout #	Allow slimd token to expire if idle.
-stderr <f>	Cause all stderr messages to be written to the file.
-stdout <f>	Causes all stdout messages to be written to the file.

Section 5. Rendering Options

-batch <width>< height>	Batch mode with optional width and height. <i>Only available if running X version of EnSight, which you get by using -X option</i>
-bbox	Render only bounding boxes in the GUI window (useful for detached displays with -prsd2 option). (See How To Setup For Parallel Rendering)
-box_resolution <#>	Resolution of bounding boxes for part culling (max 9). Implies -no_display_list
-ctarget	Set the number of polygons per "chunk" target size for parallel rendering (passed from client to server(s)).
-dconfig	Specify a display configuration file
-display_list	Use OpenGL display lists
-frustrum_cull	Use frustrum culling where possible
-glconfig	Prints current OpenGL configuration parameter defaults to screen
-glsw	Forces use of software implementation of OpenGL, bypassing the hardware graphics card (same as -X)
-gl	Sets line drawing mode to draw polygons
-ogl	Sets line drawing mode to draw lines
-no_display_list	Force EnSight to use immediate mode graphics
-no_frustrum_cull	Do not use frustrum culling
-norm_per_vert	Use one normal per vertex for flat-shading
-norm_per_poly	Use one normal per polygon for flat-shading



-multi_sampling	Turns MultiSampling on
-multi_sampling_sw	Use software MultiSampling
-no_multi_sampling	Do not use MultiSampling
-no_start_screen	Ignore the start screen image (Good for HP using TGS OpenGL)
-num_samples <#>	Specify number of samples for software multi-sampling
-num_samples_st <#>	Specify number of samples for hardware stereo multi-sampling
-occlusion_test	Use the HP occlusion extension if available
-no_occlusion_test	Do not use the HP occlusion extension
-stencil_buff	Use the OpenGL stencil buffer (even if not enabled by default)
-no_stencil_buff	Assumes there is not a working stencil buffer (some Windows video cards)
-double_buffer	Use double-buffering for the graphics window (default)
-single_buffer	Do not use double-buffering
-sort_first	Sets the default parallel rendering sorting method to be the sort first method
-sort_last	Sets the default parallel rendering sorting method to be the sort last method
-unmapdd	Don't map the detached display on startup
-X	Starts the X version of EnSight (uses Mesa OpenGL instead of native OpenGL, bypassing the hardware graphics card). <i>This option is mandatory if the -batch option is desired.</i> (This is the same as -glsw)

Section 5. X Window Specific Options

-bg <c>	Background Color colorname "c"
-fg <c>	Foreground Color colorname "c"
-fn <fn>	Font Name "fn"
-font <fn>	Same as -fn

Client Examples:

```
ensight8 -cm -p myplayfile
```

This will allow the user to do a manual connection, after which the "myplayfile" will be run.

```
ensight8 -c -gold -ports 1310 -case myfile.case
```

This will do an automatic connection (according to information in the user's ensight.connect.default file) on port 1310, using a gold seat. After the connection is made, the "myfile.case" casefile will be run.

```
ensight8 -rsh ssh -hc yellow          (or  ensight8.client -c -rsh ssh -hc yellow)
```

This will use ssh as the remote shell for an automatic connection, and will set the highlight color to yellow (instead of the default color of green).

ensight8.server [options]

-c <host>	"host" indicates where the client is running
-ctarget	Set the number of polygons per "chunk" target size for parallel rendering.
-ctries <#>	The number of times (1 second per try) to try to connect client and server.
-ether	Ethernet device name such as ln0
-gdbg	Print some debugging info for EnSight format geometries
-h, -help	Prints the usage list
-maxoff	Turns off maxsize checking
-pipe	Forces the server to use a named pipe connection (must be on same machine)
-ports <#>	Allows user specification of socket communication port.
-readerdbg	Prints user-defined-reader lib loading information in shell window upon startup of server
-writerdbg	Prints user-defined-reader lib loading information in shell window upon startup of server
-sock	Forces the server to use a socket connection
-time	Prints out timing information
-scaleg <#>	Provide scale factor to scale geometry by
-scalev <#>	Provide scale factor to scale all vectors by





-security <#>	Provide number for client to server security check
-soshostname <host>	Allows different name for servers to connect back to Server-of-Servers with

Server Examples (when started manually):

```
ensight8.server -c clientmachine -readerdbg
```

Specifies “clientmachine” as the machine on which the client is running, and that information on user-defined-reader library loading should be printed out.

```
ensight8.server -ports 1310 -scaleg 10.0 -scalev 10.0
```

Specifies that communication is to occur on port 1310, and that the geometry and all vectors are to be scaled by a factor of 10.

ensight8.sos [options]

-c <host>	“host” indicates where the client is running
-cports	Allows specification of socket communication port to the client. See also -ports, -sports.
-ctarget	Set the number of polygons per “chunk” target size for parallel rendering (passed on to servers).
-ctries <#>	The number of times (1 second per try) to try to connect client and server.
-ether	Ethernet device name such as ln0
-gdbg	Print some debugging info for EnSight format geometries (passes on to servers)
-h, -help	Prints the usage list
-maxoff	Turns off maxsize checking (passes on to servers)
-pipe	Forces the server to use a named pipe connection (must be on same machine) (passes on to servers)
-ports <#>	Allows user specification of socket communication port. (passes on to servers) Has the effect of setting -cports and -sports to be the same.
-readerdbg	Prints user-defined-reader library loading information in shell window upon startup of server (passes on to servers)
-writerdbg	Prints user-defined-reader library loading information in shell window upon startup of server (passes on to servers)
-rsh <cmd>	Remote shell program to use for automatic connection of servers. (passes on to servers)
-sock	Forces the server to use a socket connection
-scaleg <#>	Provide scale factor to scale geometry by (passes on to servers)
-scalev <#>	Provide scale factor to scale all vectors by (passes on to server)
-security <#>	Provide number for client to server security check (passes on to servers)
-soshostname <host>	Allows different name for servers to connect back to Server-of-Servers with (passes on to servers)
-sports	Allows specification of socket communication port to the servers. See also -ports, -cports.
-time	Prints out timing information (passes on to servers)

SOS (Server-of-Servers) Examples (when started manually):

```
ensight8.sos -c clientmachinename -soshostname sosmachinename
```

Specifies “clientmachinename” as the machine on which the client is running, and that the individual servers should connect back to “sosmachinename”.

```
ensight8.sos -readerdbg -gdbg
```

Specifies that the sos and any servers print out user-defined-reader library loading information, and that the servers print out EnSight data format geometry loading information.



Use Collaboration

INTRODUCTION

Collaboration between an EnSight session (Client and Server) and another EnSight client can be accomplished via the EnSight collaboration hub. This feature provides a way for a user to allow another colleague to connect to his/her running EnSight session and interactively work in a master/slave manner. The master drives the session until the slave requests and is allowed to become the master (or Pilot). The colleague will only need to start an EnSight client because, when connected via the hub, they share the EnSight server of the originating user. The master will go about the normal postprocessing operations, but will be issuing commands to the slave client to perform transformations, part editing, etc., to keep the slave current.

The EnSight collaboration hub (ensight8.collabhub) is now available on the release CD. This hub can be run on any supported computer on the network to route data between the two clients and the server. The initial connection between the originating user's client and server will be redirected through the hub when the connection is made. The colleague joins by contacting the hub which then asks the originating user if it is okay for this person to join the collaboration session. All communication between the server and client processes will transfer through the hub.

BASIC OPERATION

To start a new session:

1. Select File->Collaboration...



2. Select Session Control->New...



3. Enter Your Name.

4. Enter the Hub Hostname.

5. Enter the Hub Port Number.

6. Select Start Session to start the session and allow colleagues to make requests to join.

7. When a colleague requests to join your session you will be prompted with the name and machine information to allow them to join. Select the appropriate button as indicated in the dialog that pops up.

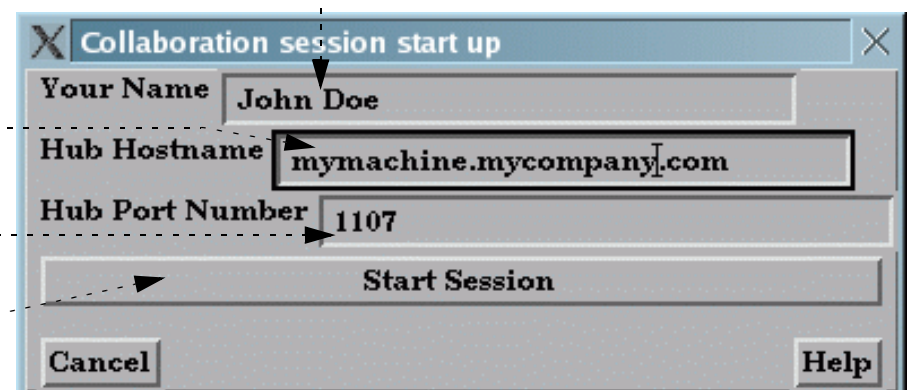



To join session:

1. Select File->Collaboration...



2. Select Session Control->Join Existing...



3. Enter Your Name.

5. Enter the Hub Hostname given to you by the person who started the collaboration session.

6. Enter the Hub Port Number given to you by the person who started the collaboration session.

7. Select Join Session to request permission to join the session.

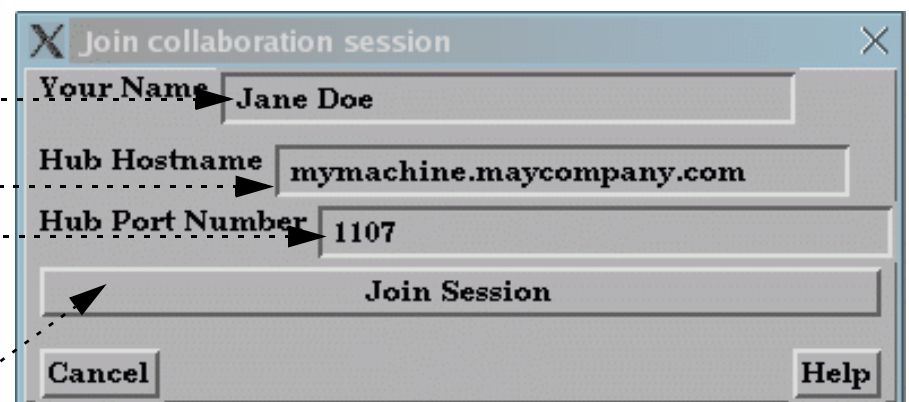

OTHER NOTES

You close or "Break Off" your session in a similar manner under File -> Collaboration -> Session Control -> Break Off



Read and Load Data
Read Data

INTRODUCTION

EnSight supports a number of file formats common in computational analysis. In addition, CEI has defined generic data formats (in both ASCII and binary versions) that can be used for both structured and unstructured data. In many cases analysis codes output this data directly (i.e. FLUENT, STAR-CD, KIVA, etc.)

Reading data into EnSight can be a **one-step quick process** if an association is known for the data format type **and you wish to load all parts**. This simplified method will be shown below. It is accessed under File->Open.....

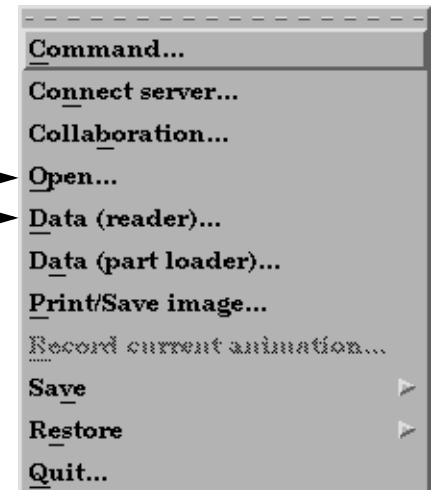

A **two-step process** is also available. It is accessed under File->Data (reader)..... This is the more traditional method for EnSight, and provides more control over the reading of data files and the part creation process. The first step is the selection of appropriate files. The second step is the loading of parts. Both steps have many similarities regardless of the data format. These basic steps are described below. Variations from the methods shown will be described in Chapter 2 ([Reader Basics](#)) of the User Manual for the various formats.

One-Step Quick Method (File->Open...)

[ensight_reader_extension.map](#) file example:

Two-Step Method (File->Data (reader)...) First Step (Specifying Files):

Second Step (Loading Parts):

BASIC OPERATION

One-Step Quick Method (File->Open...)

The one-step method of reading data into EnSight works for most formats and requires a file extension-to-reader mapping file (ensight_reader_extension.map). This file can reside in the site_preferences directory and/or each user can have his own personal one in his .ensight8 directory. A sample of this file is shown below. The mapping file associates file extensions to readers. If this file is not provided or an association is not known, or the format doesn't allow it due to required intermediate information (such as Plot3D currently), the one-step method (Open...) will default to the first step of the two-step method (Data (reader)...)

1. Select File > Open...

2. Select the desired data directory using the Directories list.

You can also enter a directory name directly in the Filter field to jump to that directory. The Filter can also provide file name filtering, e.g. using *.case to display in the Files list only those files that end with .case.

3. Select whether to replace any currently loaded data, or keep it and append the new data.

4. Select the desired file in the Files list.

This file's extension is what will be mapped to a reader in the ensight_reader_extension.map.

5. Click Okay.

(Double clicking the file in step 4. is also allowed.)

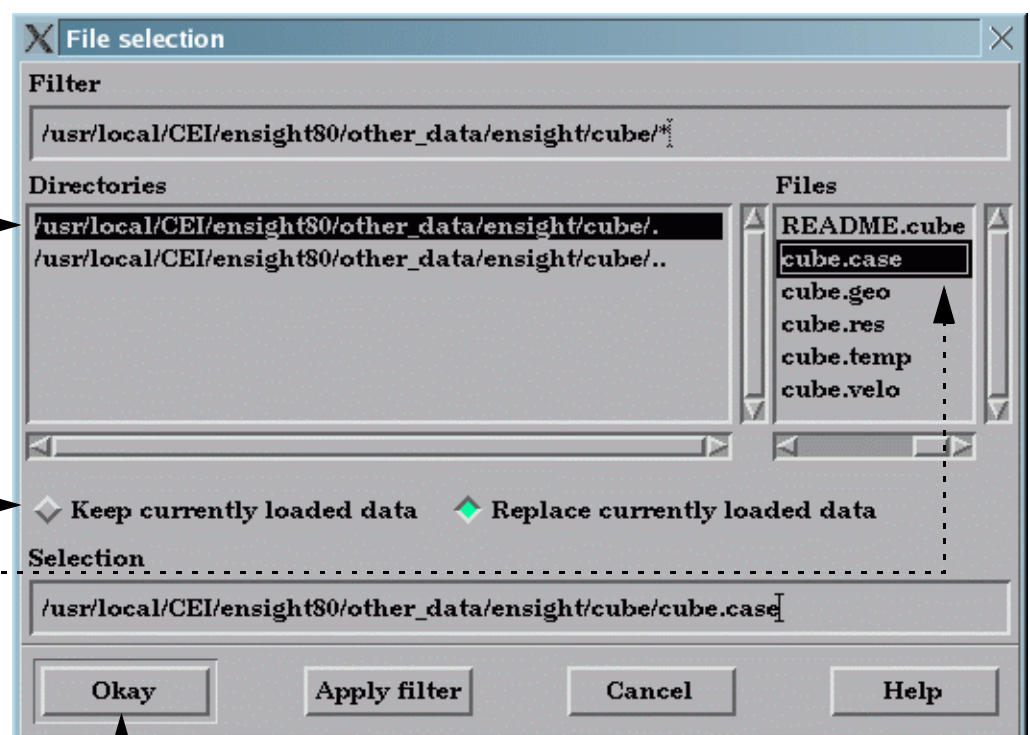

At this point (provided the association is successful and the data is readable) all parts of the model will be loaded into EnSight and will appear in the graphics screen and in the Parts List. If the association is not successful, the File Selection dialog for the Data (reader) method will appear and you will default to the two-step method.



EnSight_reader_extension.map file example:

The following is a sample containing associations for EnSight Case, EnSight5, STL and MSC/Dytran:

```

EnSight file extension to format association file
Version 1.0
#
# Comment lines start with a #
#
#
# The format of this file is as follows:
#
# READER_NAME: reader name as it appears in the Format chooser in the EnSight Data Reader dialog
# NUM_FILE_1: the number of file_1_ext lines to follow
# FILE_1_EXT: the extension that follows a file name minus the ".", i.e., "geo", "case", etc.
#           There should be one definition after the :. Multiple FILE_1_EXT lines may exist
# NUM_FILE_2: the number of file_2_ext lines to follow
# FILE_2_EXT: the extension of a second file that will act as the result file. This is only used
#           for formats that require two file names. As with FILE_1_EXT, there may be multiple
#           FILE_2_EXT lines.
# ELEMENT_REP: A key word that describes how the parts will be loaded (all parts will be loaded the
#           same way). One of the following:
#           "3D border, 2D full"
#           "3D feature, 2D full"
#           "3D nonvisual, 2D full"
#           "Border"
#           "Feature angle"
#           "Bounding Box"
#           "Full"
#           "Non Visual"
#           If option is not set then 3D border, 2D full is used
# READ_BEFORE: (optional) The name of a command file to play before reading the file(s)
# READ_AFTER: (optional) The name of a command file to read after loading the parts

# Definition for Case files

READER_NAME: Case
NUM_FILE_1: 2
FILE_1_EXT: case
FILE_1_EXT: encas
ELEMENT_REP: 3D feature, 2D full

# Definition for EnSight5 files

READER_NAME: EnSight 5
NUM_FILE_1: 2
FILE_1_EXT: geo
FILE_1_EXT: GEOM
NUM_FILE_2: 2
FILE_2_EXT: res
FILE_2_EXT: RESULTS
ELEMENT_REP: 3D feature, 2D full

# Definition for STL files

READER_NAME: STL
NUM_FILE_1: 2
FILE_1_EXT: stl
FILE_1_EXT: STL
ELEMENT_REP: 3D feature, 2D full

# Definition for Dytran files

READER_NAME: MSC/Dytran
NUM_FILE_1: 2
FILE_1_EXT: dat
FILE_1_EXT: ARC
ELEMENT_REP: 3D border, 2D full
READ_AFTER: ~/.ensight8/read_after_dytran.cmd

```





Two-Step Method (File->Data (reader)...) Read Data

First Step (Specifying Files):

Each data format requires a different set of files for proper data loading. A table is provided below that briefly describes these files for various formats. Links to the User Manual are also provided - so you can get detailed information for each format

1. Select File > Data (Reader)...

2. Select the desired data directory using the Directories list.

You can also enter a directory name directly in the Filter field to jump to that directory. The Filter can also provide file name filtering, e.g. using *.geo to display in the Files list only those files that end with .geo.

3. Select the desired format.

The list shown is dependent on the presence of internal and user-defined readers at your site, and on your preference settings.

Case	ESTET	Nastran OP2
EnSight 5	ExodusIlgold	N3S
ABAQUS	FAST UNSTRUCTURED	NetCDF
ABAQUS_ODB	FIDAP NEUTRAL	Plot3D
Medina bif/bof	D_Fluent	RADIOSS_4.x
ANSYS RESULTS	FLUENT UNIVERSAL	SCRYU
Ansys Results(v8)	Special HDF5	Silo
AVUS	LS-DYNA3D	STL
CFF	Movie	Tecplot_ASCII
CFX-4	MPGS 4.1	TECPLOT_7.x
CGNS	MSC/Dytran	Vectis

4. If desired, specify a starting time

The default is the last time step, unless you have set a preference otherwise.

5. If the file is binary, set the correct byte order.

For most formats, EnSight can determine this automatically, and your selection is ignored. But if it can't determine, it will use this selection.

6. Select the desired file(s) in the Files list one at a time and click the appropriate (Set) button for the file.

The required files vary per Format type. See the table on the next page.

1st field: (Set) Geometry (or something similar). All formats will require something in this field.

2nd Field: (Set) Results or (Set) Params. Some formats will require input of a file in this field. A few formats will allow special parameters in this field.

3rd Field: (Set) measured. All but the Casefile format will allow input of measured data. See [EnSight5 Measured/Particle File Format](#)

4th Field: (Set) boundary. Only the Plot3d, Casefile, and Special HDF5 structured formats will pay attention to input in this field. See [EnSight Boundary File Format](#)

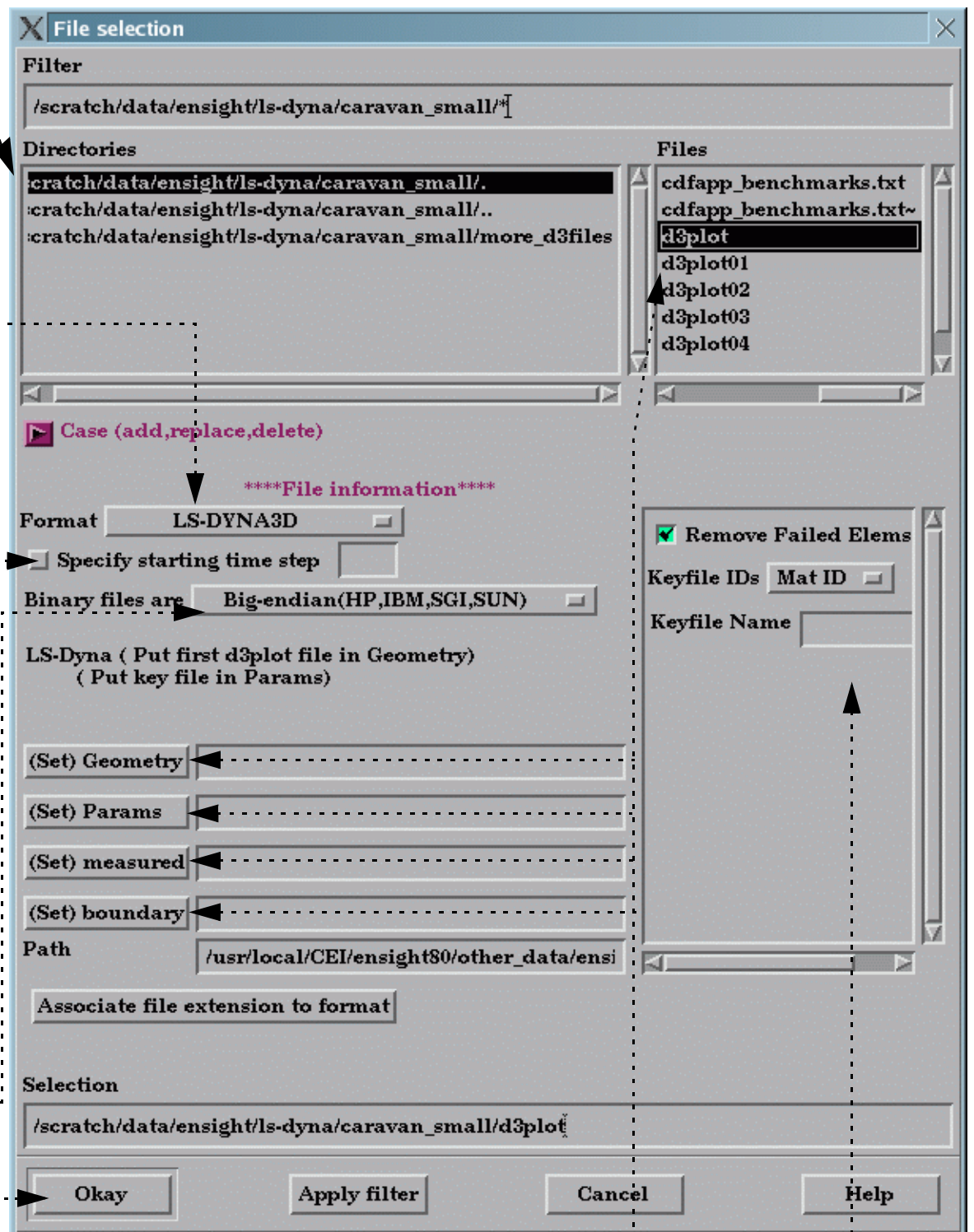

7. Select any appropriate extra options if the chosen format has any. (Most do not.)

8. Click Okay, once you have specified the files and any options.

The Data Part Loader dialog for the applicable format will now open and you are ready for the second step in the data reading process.

There are a couple of exceptions to this, where additional information must be entered. For example, the Plot3D reader requires some confirmation on various formatting possibilities, the ESTET reader allows for vector building from scalar components, etc. If not obvious, please see the details for specific readers in Chapter 2 ([Other Readers](#)) of the User Manual



The following table details the files required for each file type for the Data (reader)... method:

Format Type		Description	Geometry Field (1st Field)	Result Field (2nd Field) Blank field indicates not used	Extra Options?
Case A "wrapper" format for other formats	EnSight Gold	CEI format defined for version 7.x of EnSight. Loads into EnSight much quicker and is much more memory efficient. (To troubleshoot, see How To Use ens_checker)	file.case		
	EnSight6	CEI format defined for version 6.x of EnSight. Typically a superset of EnSight 5 format with support for structured data. (To troubleshoot, see How To Use ens_checker)	file.case		
EnSight5		CEI format defined for version 5.x of EnSight. Unstructured only	file.geo	file.res If variables provided.	
ABAQUS		Data written from ABAQUS (commercial FEM solver).	file.fil Will also read file.dat if present in the same directory with the same root file name.		
ABAQUS_ODB		Data written from ABAQUS (commercial FEM solver).	file.odb	Optional parameter string. See ...	
ANSYS RESULTS		Older reader for data written from ANSYS (commercial FEM solver).	file.rst (also .rth, .rfl, .rmq)		
Ansyes Results (v8)		Newer reader for data written from ANSYS (commercial FEM solver).	file.rst (also .rth, .rfl, .rmq)		
AVUS		Formerly Cobalt60, for static data	file.grd	file.sol (solution or restart file)	
	Case	Formerly Cobalt60 Case, for transient data	file.txt (text AVUS case file)	file.sol (solution or restart file)	
CFF		Unsupported CFF reader	file		
CFX-4		Data written from CFX (commercial CFD solver).	file.dmp		
CGNS			file.cgns		
ESTET		Data written from ESTET (commercial CFD solver).	file		
ExodusIIgold		Data written from Exodus II CFD solver	file.exo (or similar)		Yes
FAST UNSTRUCTURED		NASA FAST format for unstructured (tetrahedral) data.	file.xyz (or similar)	file.res. NOTE! Do not use your solution file (e.g. file.q) here. You must create a special results file to handle FAST variable files. See FAST UNSTRUCTURED Result file format .	
FIDAP NEUTRAL		Data written from FIDAP (commercial CFD solver) in the NEUTRAL format.	file.fdneut (or similar)		
D_Fluent		Data written from Fluent (commercial CFD solver) in the UNIVERSAL format	file.cas	file.dat	
FLUENT UNIVERSAL		Data written from Fluent (commercial CFD solver) in the UNIVERSAL format	file.unv (or similar)		
Special HDF5		Data written for specific implementation of HDF5 format	file		
LS-DYNA3D		Data written from LS-Dyna3D (commercial FEM solver) in single or multiple unstructured C-binary format	file.d3plot		Yes





Format Type	Description	Geometry Field (1st Field)	Result Field (2nd Field) Blank field indicates not used	Extra Options?
Medina bif/bof	Data written from Medina BIF/BOF PERMAS code. (commercial solver).	file.konfig (Ascii)		
Movie	Data in MOVIE.BYU format.	file.geo	file.res	
MPGS 4.1	CEI format for EnSight prior to version 5.0	file.geo	file.res	
MSC/Dytran	Data written for Dytran (commercial solver)	file.dat or file.arc		
Nastran OP2	Data written for NASTRAN (commercial FEM solver) in .op2 format. Only PDA Patran (PARAM POST = -1) and SDRC Ideas (PARAM POST = -2) are supported.	file.op2		
N3S	Data written from N3S (commercial CFD solver).	file.geo	N3S format file.res	
NetCDF	Data written for specific implementation of Unidata NetCDF	file.ncase		
PLOT3D	NASA format for multiblock, structured data.	file.x (or similar)	<p>If your solution (Q) file contains the five standard variables, you can use it as the results file.</p> <p>If you have a non-standard Q file (or a function file) you must create a special results file to handle PLOT3D variable files. See PLOT3D Results File Format.</p>	
RADIOSS_4.x	Data written for Radioss solver	file.anim (or similar)		
SCRYU	Data written for SCRYU solver	file.pre		
Silo	Data written for Silo format	file.silo or file.case		
STL	Data written in STL format	file.stl (or similar)		
TECPLOT 7.x	Data written for Tecplot binary 7	file.plt		
Tecplot_ASCII	Data written for Tecplot ASCII 10	file.dat		
Vectis	Data written for Vectis solver	file.TRI, file.POS (or similar)		
Other User Defined	Any format for which a shared library data reader has been developed.	Depends on reader	Depends on reader	Depends on reader



Second Step (Loading Parts):

There are several ways that parts are specified for loading into EnSight. Many formats use similar procedures, while a few have custom methods. Below we present the more common part loading methods. For formats that vary from these - you will be referred to the User Manual which gives the details for each.

To build **unstructured** parts for EnSight Case (EnSight Gold, EnSight6), EnSight5, ABAQUS_ODB, Medina bif/bof, Ansys Results (v8), AVUS, AVUS Case, CFF, CFX-4, CGNS, ExodusIIgold, Special HDF5, LS-DYNA3D, MSC/Dytran, Nastran OP2, NetCDF, RADIOSS_4.x, SCRYU, Silo, TECPLOT 7.x, Tecplot_ASCII, Vectis, and any other User-defined formats:

1. If the **Data Part Loader** dialog is not open, select **File > Data (Part Loader)**...

The available parts are listed in the Parts List. You can build them all by clicking Load All at the bottom. Alternately, you can build the selected ones or even one by one and choose a different visual representation and part name for each.

To build selected parts:

2. Select the desired part(s) in the **Parts list**.
3. Choose the desired initial **Visual Representation** for the select part(s).
4. If desired, enter a name for the part (to use in the Main Parts list). The default name is the same as the entry in this Parts List.
5. Click **Load Selected**.
6. Click **Close** when done.

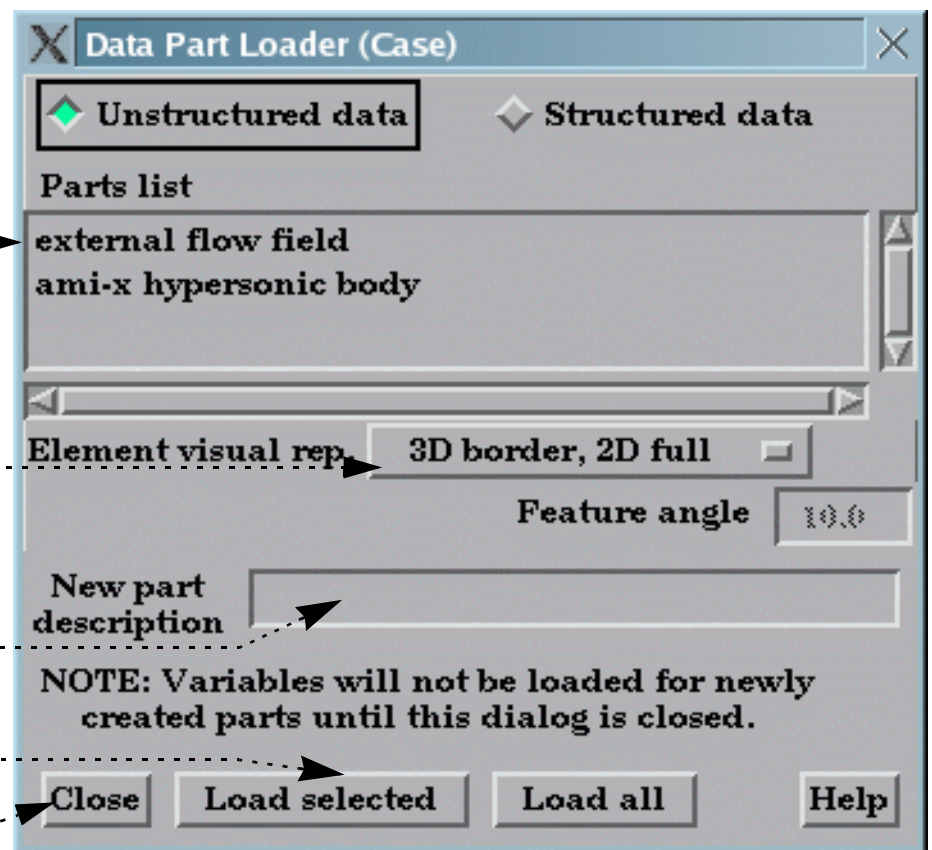

Note that you can re-enter the part loader and build more parts later for formats which use this method.

For ANSYS RESULTS, FAST UNSTRUCTURED, FIDAP NEUTRAL, FLUENT UNIVERSAL, Movie, and MPGS 4.1 formats:

All parts defined in the file will be loaded to the EnSight server. However, you have a choice for the initial visual representation of some parts as displayed on the client. The choice is made with the Load pull-down:

All Parts: all parts are loaded to the client in the default visual representation (typically 3D Border, 2D Full).

Part 1 Only: Only the first part is loaded to the client in the default visual representation. The other parts will have the NonVisual representation.

All But Part 1: All parts *other* than part 1 are loaded to the client in the default visual representation. Part 1 will be NonVisual.

No Parts: No parts are loaded to the client (*i.e.* the representation of all parts is set to NonVisual).

Note that you can easily change the visual representation of a part at any time. See [How To Change Visual Representation](#) for more information.

1. Select the desired **Load option**.
2. Click **Okay**.

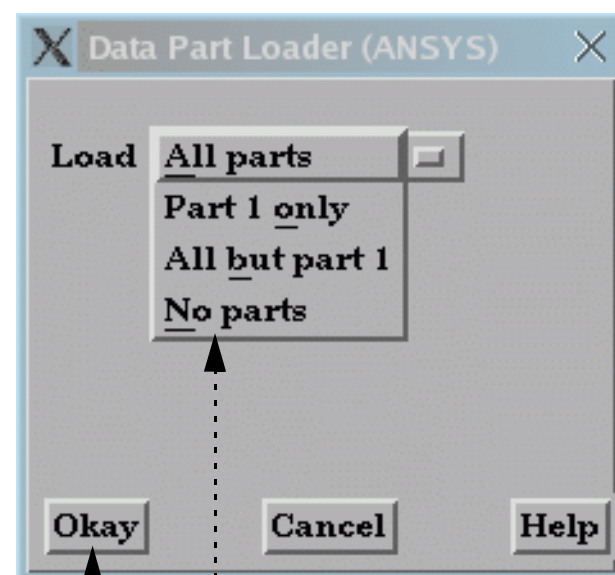

Note that you will not be able to re-enter the part loader for formats which use this method

For the N3S format, see [N3S Reader](#)

For the Abaqus_fil format all parts are automatically loaded.





To build **structured** parts for EnSight Case (EnSight Gold, EnSight6), Special HDF5, Plot3D, and any other User-defined formats:

1. If the Data Part Loader dialog is not open, select File > Data (Part Loader)...

2. Be sure Structured Data is selected to display only the structured parts in the Parts List.

3. Select the desired part(s) in the Parts List.

4. Choose the desired initial **Visual Representation** for the select part(s).

5. If the selected part has Iblanking, you can build based on the value (Inside selects cells where Iblank=1, Outside selects Iblank=0, All selects all cells ignoring Iblanking).

6. You can specify From, To, and Step IJK values for the selected part(s). The From and To values are inclusive.

Valid values in the From and To fields are numbers advancing from 1(the min for each part), or numbers decreasing from 0(the max for each part):

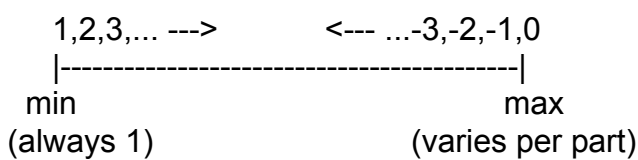

If you specify values that will be outside of the range of an individual part, the proper min or max values for the given part will be used.

The Min and Max fields are for reference only.

8. If desired, enter a name for the part (to use in the Main Parts list). The default name is the same as the entry in the Parts List.

9. Open this turndown section to create unstructured parts based on boundary Iblanking from any parts created above.

10. Click Create and Load Part.

11. Click Close when done.

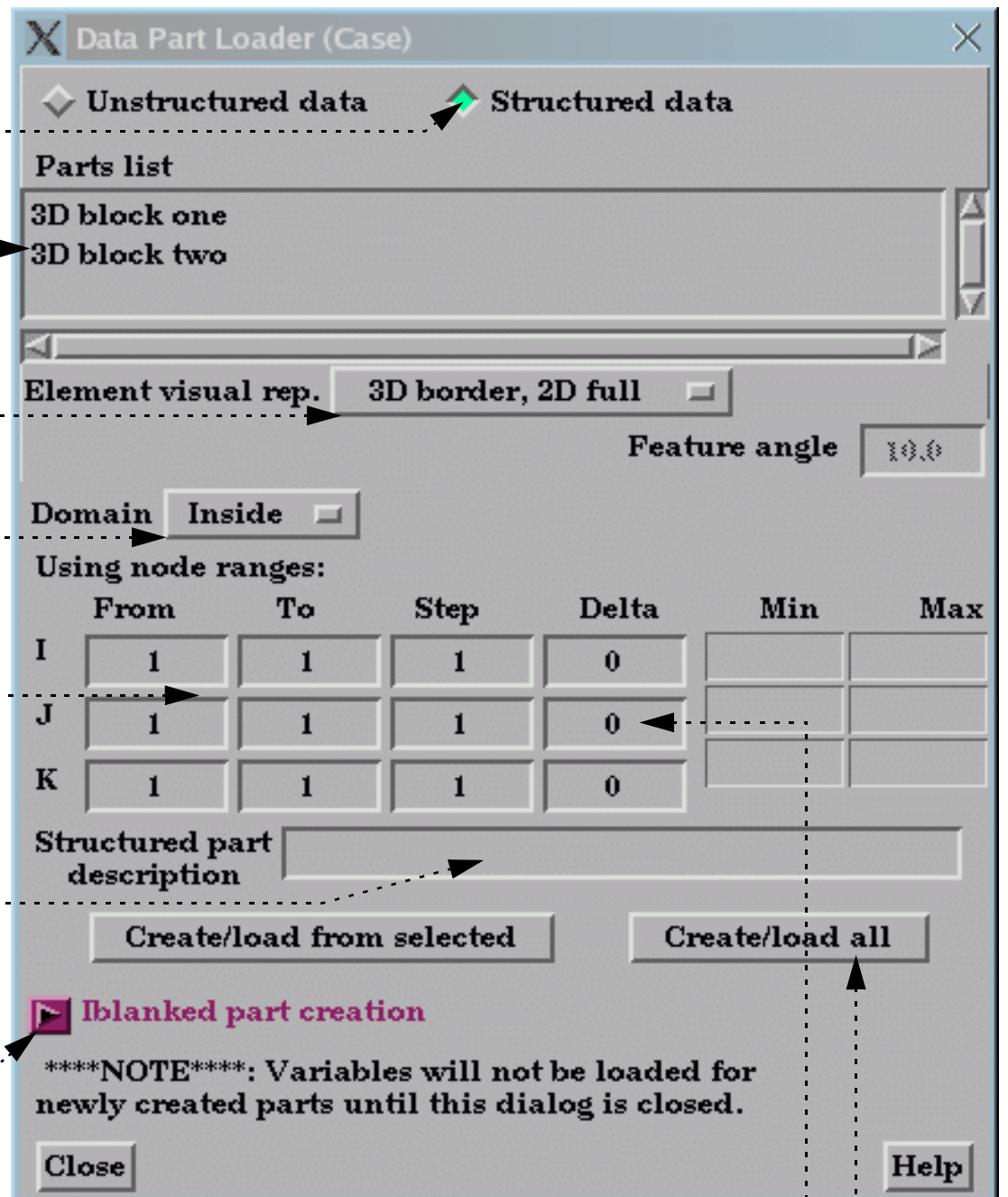

7. If you desire to extract multiple surfaces (at a constant delta) from the same zone, set one of the directions to the desired non-zero delta value.

This is a “blade row” kind of operation. Please note that this results in an unstructured part instead of a structured one.

For the ESTET format the procedure is similar. See [ESTET Reader](#)



SEE ALSO

[How To Use ens_checker](#)

User Manual:

- [Reader Basics](#)
- [EnSight Case Reader](#)
- [EnSight5 Reader](#)
- [ABAQUS_FIL Reader](#)
- [ABAQUS_ODB Reader](#)
- [Medina BIF-BOF PERMAS Reader](#)
- [ANSYS Reader](#)
- [AVUS Reader](#)
- [CFF Reader](#)
- [CFX4 Reader](#)
- [CGNS Reader](#)
- [ESTET Reader](#)
- [EXODUS II Gold Reader](#)
- [FAST UNSTRUCTURED Reader](#)
- [FIDAP NEUTRAL Reader](#)
- [FLUENT Direct Reader](#)
- [FLUENT UNIVERSAL Reader](#)
- [HDF Reader](#)
- [LS-DYNA Reader](#)
- [Movie.BYU Reader](#)
- [MPGS 4.1 Reader](#)
- [MSC.DYTRAN Reader](#)
- [MSC.NASTRAN Reader](#)
- [N3S Reader](#)
- [NetCDF Reader](#)
- [PLOT3D Reader](#)
- [RADIOSS Reader](#)
- [SCRYU Reader](#)
- [SILO Reader](#)
- [STL Reader](#)
- [Tecplot Reader](#)
- [Vectis Reader](#)





Use ens_checker

INTRODUCTION

This program attempts to check the integrity of the EnSight Gold (or EnSight6) file formats. Most files that pass this check will be able to be read by EnSight (see Other Notes below). If EnSight Gold (or EnSight6) data fails to read into EnSight, one should run it through this checker to see if any problems are found.

Ens_checker makes no attempt to check the validity of floating point values, such as coordinates, results, etc. It is just checking the existence and format of such.

BASIC OPERATION

Program invocation:

If you invoke the program without any arguments, it will prompt you for the casefile to read. For example:

```
> ens_checker

*****
*   EnSight Data Format Checker                               *
*   =====                                                 *
*   Currently,                                             *
*   1. Must be run from directory in which casefile is located. *
*   2. Handles EnSight6 and EnSight Gold formats only.      *
*   3. Does not process SOS casefiles.                    *
*****

<Enter casefile name (must be in directory containing it!) > mydata.case
```

You can alternatively invoke the program with the casefile on the command line.

```
> ens_checker mydata.case
```

Sample runs:

As ens_checker works it will be providing feedback. This feedback is important in interpreting what is wrong in the files. Here is a sample run, which was successful:

```
> ens_checker 3by3.case

*****
*   EnSight Data Format Checker                               *
*   =====                                                 *
*   Currently,                                             *
*   1. Must be run from directory in which casefile is located. *
*   2. Handles EnSight6 and EnSight Gold formats only.      *
*   3. Does not process SOS casefiles.                    *
*****

<Enter casefile name (must be in directory containing it!) > 3by3.case

Casefile to Process:
-----
3by3.case   (Opened successfully)

-----

Major Sections Found:
-----
Required FORMAT   section      (at line 1)
Required GEOMETRY section      (at line 4)
Optional VARIABLE section      (at line 7)
Optional TIME     section      (at line 11)

-----

FORMAT Section:
-----
EnSight 6 Format   (set at line 2)
```

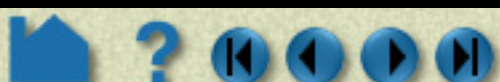



```
-----
TIME section:
-----
Info for timeset number: 1
-----
Time set: 1 (at line 12)
  No description provided
  Number of steps:      1 (at line 13)
  Time values:          (starting on line 14)
                        time values[1] = 0

>-----<
> TIME section OKAY <
>-----<

-----
GEOMETRY Section:
-----

-----
Model filename is: 3by3.geo (at line 5)

  Static geometry

-----
Opened 3by3.geo successfully

File type is: ASCII
Description 1: EnSight test geometry file
Description 2: =====
node ids: assign
element ids: assign

Global section:
  Number of nodes: 64
  Coordinates for (64) nodes found

Part 1:
  Description is: 3 x 3 xy
  Unstructured Part
  Number of quad4 elements is: 9
  Connectivities for (9) quad4 elements found

Part 2:
  Description is: 3 x 3 yz
  Unstructured Part
  Number of quad4 elements is: 9
  Connectivities for (9) quad4 elements found

Part 3:
  Description is: 3 x 3 xz
  Unstructured Part
  Number of quad4 elements is: 9
  Connectivities for (9) quad4 elements found

Part 4:
  Description is: 3 x 3 45
  Unstructured Part
  Number of quad4 elements is: 9
  Connectivities for (9) quad4 elements found

>-----<
> GEOMETRY section OKAY <
>-----<

-----
VARIABLE Section:
-----

scalar per node: scalar (at line 8)
  Filename is: 3by3.scl
  Non transient variable
```





```

-----
Opened 3by3.scl successfully

Description: 3by3 scalar variable

Global section:
  (64) Nodal scalar values for unstructured nodes found

vector per node:  vector      (at line 9)
Filename is: 3by3.vct
Non transient variable

-----
Opened 3by3.vct successfully

Description: 3by3 vector variable

Global section:
  (192) Nodal vector values for unstructured nodes found

>-----<
> VARIABLE section OKAY <
>-----<

                >----- Hooray! -----<
                > <
                > Data verification SUCCESSFUL <
                > <
                > with No Warnings <
                > <
                >-----<
    
```

And here is a sample run, with a problem, namely a 'block' line is missing:

```

> ens_checker 3by3s.case

*****
* EnSight Data Format Checker *
* ===== *
* Currently, *
* 1. Must be run from directory in which casefile is located. *
* 2. Handles EnSight6 and EnSight Gold formats only. *
* 3. Does not process SOS casefiles. *
*****

Casefile to Process:
-----
3by3s.case (Opened successfully)

-----
Major Sections Found:
-----
Required FORMAT section (at line 1)
Required GEOMETRY section (at line 4)
Optional VARIABLE section (at line 7)
Optional TIME section (at line 11)

-----
FORMAT Section:
-----
EnSight 6 Format (set at line 2)

-----
TIME section:
-----
Info for timeset number: 1
-----
    
```





```
Time set: 1 (at line 12)
  No description provided
  Number of steps: 1 (at line 13)
  Time values: (starting on line 14)
                time values[1] = 0
```

```
>-----<
> TIME section OKAY <
>-----<
```

```
-----
GEOMETRY Section:
-----
```

```
-----
Model filename is: 3by3s.geo (at line 5)
```

```
Static geometry
```

```
-----
Opened 3by3s.geo successfully
```

```
File type is: ASCII
Description 1: EnSight test geometry file
Description 2: =====
node ids: assign
element ids: assign
```

```
Global section:
  Number of nodes: 0
```

```
Part 1:
  Description is: 3 x 3 xy block
  Structured Part
  Not iblanked
  i j k = 4 4 1
  Number of nodes: 16
  Number of cells: 9
    Block X coordinates for (16) nodes found
    Block Y coordinates for (16) nodes found
    Block Z coordinates for (16) nodes found
```

```
Part 2:
  Description is: 3 x 3 yz block
```

```
====> Problem:
```

```
-----
Looking for one of the following valid line types:
  element type (unstructured types, any of the following:
                point   tria6   tetra10   penta15
                bar2    quad4   pyramid5   hexa8
                bar3    quad8   pyramid13  hexa20
                tria3   tetra4   penta6
  block (structured block)
  part (the next part)
but found the following:
4      4      1
```

```
>-----<
> GEOMETRY section FAILED <
>-----<
```

```
>-*-*-*-*-* bummer! *-*-*-*-*<
> <
> Verification of the data FAILED <
> <
>-*-*-*-*-*<
```

After fixing the 'block' line and running the program again, another problem is encountered - namely, an extra space





at the end of the second line of x coordinates for the block that is part 2.

```
> ens_checker 3by3s.case
```

```
*****
*   EnSight Data Format Checker                               *
*   =====                                                 *
*   Currently,                                              *
*   1. Must be run from directory in which casefile is located. *
*   2. Handles EnSight6 and EnSight Gold formats only.      *
*   3. Does not process SOS casefiles.                      *
*****
```

```
Casefile to Process:
-----
```

```
3by3s.case   (Opened successfully)
```

```
-----
Major Sections Found:
-----
```

```
Required FORMAT   section   (at line 1)
Required GEOMETRY section   (at line 4)
Optional VARIABLE section   (at line 7)
Optional TIME     section   (at line 11)
```

```
-----
FORMAT Section:
-----
```

```
EnSight 6 Format   (set at line 2)
```

```
-----
TIME section:
-----
```

```
Info for timeset number: 1
-----
```

```
Time set: 1   (at line 12)
  No description provided
  Number of steps:      1   (at line 13)
  Time values:          (starting on line 14)
                        time values[1] = 0
```

```
>-----<
> TIME section OKAY <
>-----<
```

```
-----
GEOMETRY Section:
-----
```

```
-----
Model filename is:   3by3s.geo   (at line 5)
```

```
  Static geometry
```

```
-----
Opened 3by3s.geo successfully
```

```
File type is:      ASCII
Description 1:     EnSight test geometry file
Description 2:     =====
node ids:         assign
element ids:      assign
```

```
Global section:
  Number of nodes: 0
```

```
Part 1:
  Description is: 3 x 3 xy block
  Structured Part
  Not iblanked
  i j k = 4 4 1
  Number of nodes: 16
```





```

Number of cells: 9
  Block X coordinates for (16) nodes found
  Block Y coordinates for (16) nodes found
  Block Z coordinates for (16) nodes found

```

Part 2:

```

Description is: 3 x 3 yz block
Structured Part
Not iblanked
i j k = 4 4 1
Number of nodes: 16
Number of cells: 9

```

==> Problem:

```

-----
Previous lines end with 1 extra chars on the line,
but line 2 has 2 extra chars. The lines must be consistent
or EnSight will have trouble reading it.

```

==> Problem:

```

-----
Not successful reading 16 X block coordinates

```

```

>-----<
> GEOMETRY section FAILED <
>-----<

>-*-*-*-*-* bummer! *-*-*-*-*<
> <
> Verification of the data FAILED <
> <
>-*-*-*-*-*<

```

After eliminating the extra space, the file then checked out fine.

ADVANCED USAGE

Redirecting Output to a File:

ens_checker is writing to stderr, so if you want to redirect output to a file, you need to use ">&". For example, the following will place the output of the run into a file called output.file:

```
> ens_checker 3by3.case >& output.file
```

OTHER NOTES

The word "most" is used above because one of the things that could pass the checker, but fail in EnSight is element connectivity of EnSight6 files with node ids. The ens_checker checks that node ids used in the element connectivities lie within the min and max range of the node ids, but does not verify that there is actually a node with each individual id.

The validity of model extents, presence of nan's, etc. are currently checked to some degree in ens_checker, but again, this is a format checker - not a model integrity checker.

SEE ALSO

User Manual:

[EnSight Gold Casefile Format](#)
[EnSight6 Casefile Format](#)

INTRODUCTION

Normal operation of EnSight involves one client process (the graphics and GUI) interfacing with one server process (data I/O and computation) to postprocess your data. There however several other configurations possible. One of these is the ability to connect a single client to multiple servers at the same time, with each server maintaining a unique dataset. Each of these servers can potentially run on different machines.

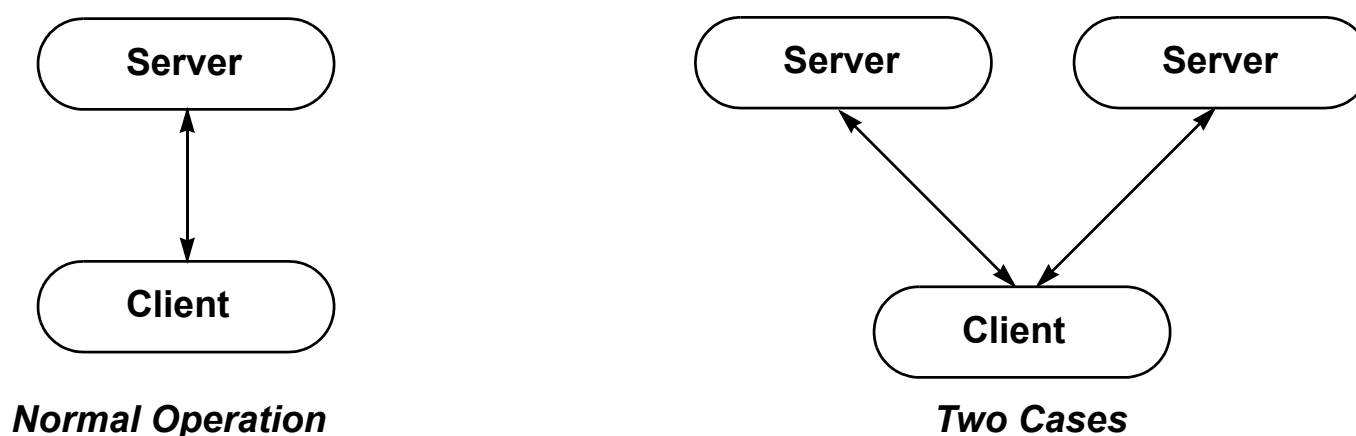

The main use of this capability is to visualize multiple datasets simultaneously. Each dataset is loaded into a separate case and can be viewed in the same window or in separate viewports. You can perform before and after comparisons of the same problem or compare experimental with simulated results. The same operation (such as a clip or a particle trace) can be performed in both cases simultaneously. Created parts always belong to the same case as the parent from which the part was created. As a consequence, you cannot perform operations that combine parts (such as a merge) from multiple cases.

When EnSight reads a new case, it searches the current list of variables for matches with the variables from the new case. If it finds a match (based on an exact match of the variable name), it will not enter the new variable in the list. Rather, the matched name will be used for both. This behavior is based on the assumption that the identical variable names represent the same physical entity and should therefore be treated the same. If the new variable name does not match any existing name, the new variable is added to the list as usual.

Up to 16 cases can be active at one time. You can add a new case or replace an existing case to a running session by using the File->Open... process (if you want to load all parts and don't need to control other options available when loading cases) or the File->Data (reader)... process (which provides greater control). Adding a case starts a new server process, connects it to the client, and either loads all the parts (if you used Open...) or allows you to specify the data format and files as well as which parts to load into the new server and what optional settings to use as the case is created. One of the helpful uses of the replace case option is to load a new dataset into EnSight without re-starting the client. You can of course also delete cases you no longer need.

BASIC OPERATION

Simplified case operations (Add or Replace and load all parts) can be accessed through the File->Open dialog. All other case operations (including control of various options) can be accessed through the Case menu or through the File->Data (reader) dialog. Both methods will be shown below.

Add a Case

To add a case to a running EnSight session

Using simple File->Open dialog method:

1. Select File->Open... to open the File Selection dialog.
2. Select Keep currently loaded data
This will add, rather than replace, the case
3. Select the desired directory and files for the new case.
4. Click Okay.

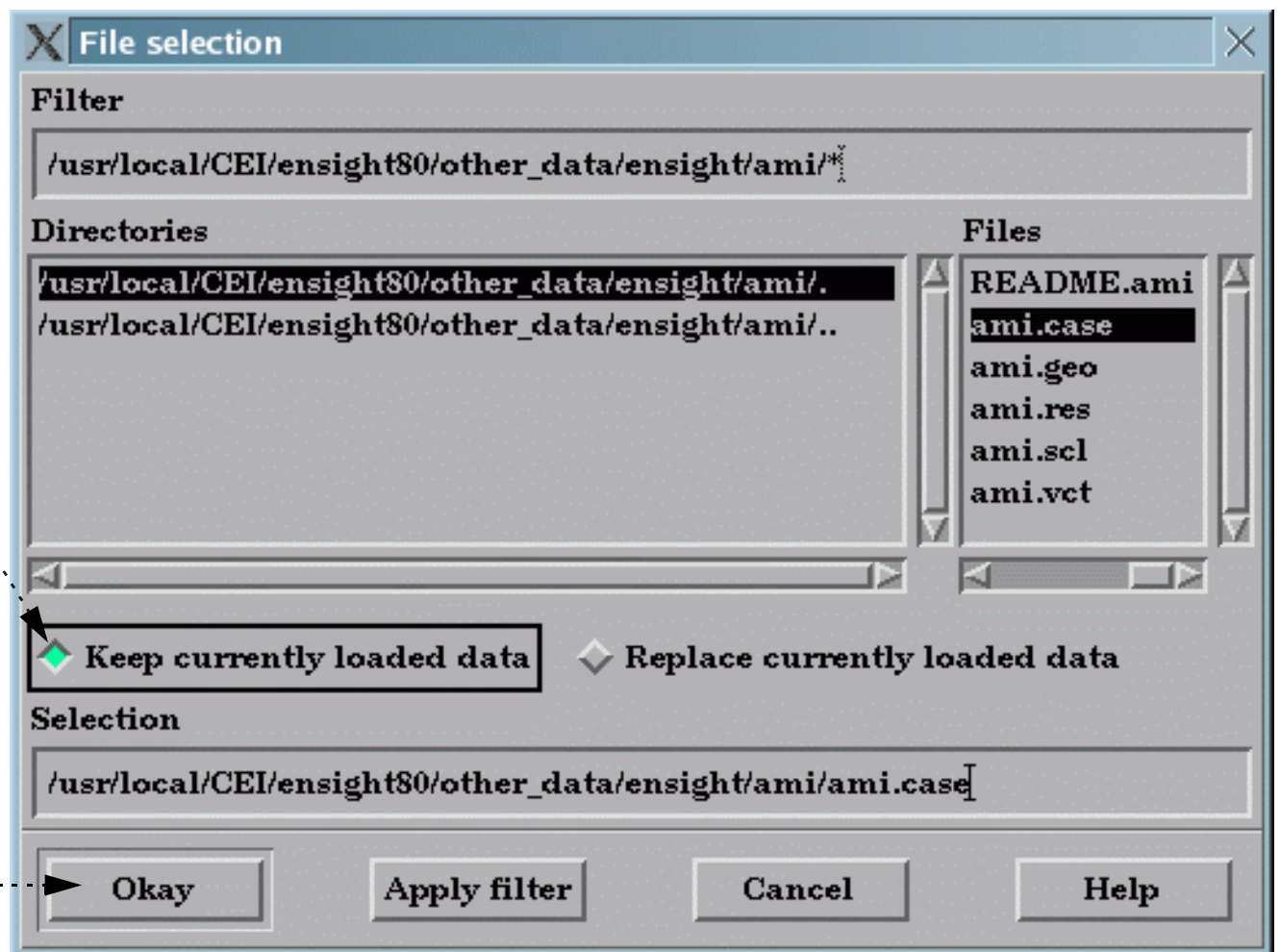

The EnSight client will now start the connection process for the new server. If your original connection was automatic, the new server will be started automatically. If your original connection was manual, you will have to manually start another server. You can follow the progress of the connection in the Message area. See the EnSight Getting Started Manual or [How To Start and Connect Automatically](#) for more information. Once connected, EnSight will also load all parts of this new case if you use this method.

Using File->Data (reader) dialog method:

1. Select Case > Add, Replace, Delete... to open the data reader File Selection dialog.

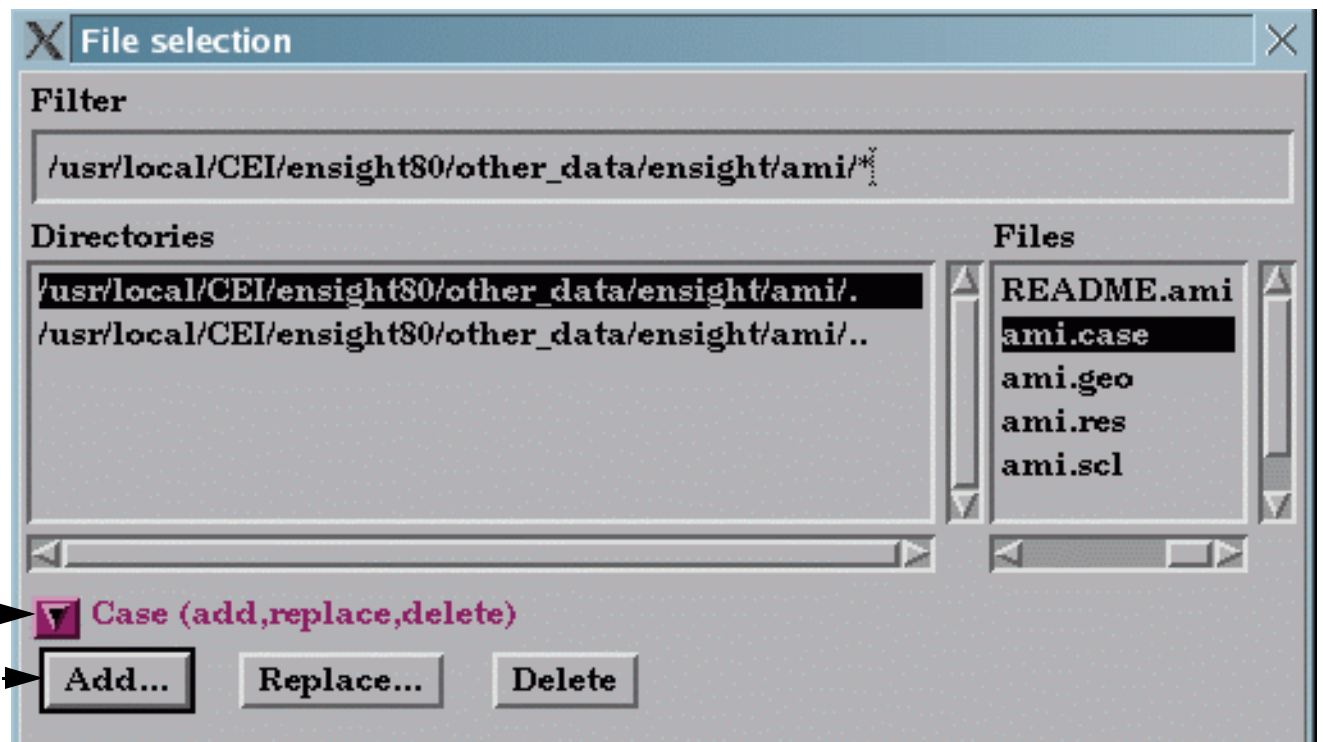

2. If the Case section is not open, click the turndown:

3. Click Add...

4. If desired, enter a name for the case (other than the default).

The name will be displayed in the Case menu so this case can be selected as the current case.

5. Set optional settings.

Create new viewport for this case will place the new case in a new viewport.

Apply Context From Case 1 will cause the new case to inherit positioning etc. from case 1.

Reflect Model About Axis allows the model to be reflected as it is read in. Pick the axis and specify the origin location.

6. Click Okay.

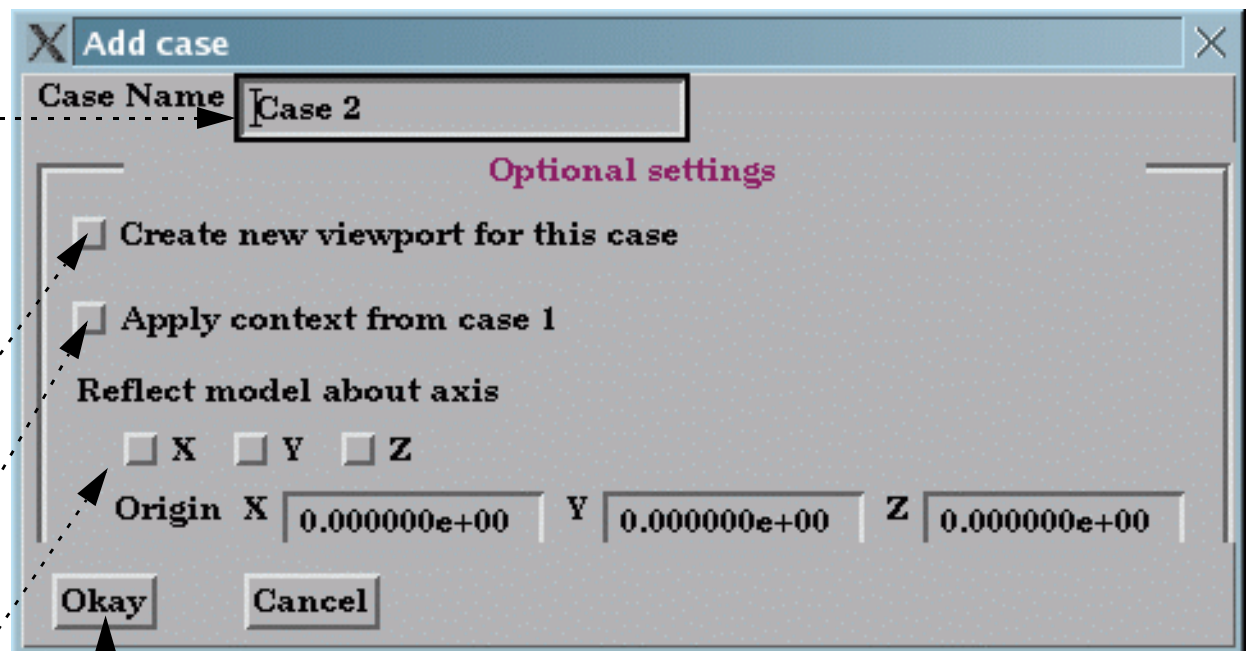

The EnSight client will now start the connection process for the new server. If your original connection was automatic, the new server will be started automatically. If your original connection was manual, you will have to manually start another server. You can follow the progress of the connection in the Message area. See the EnSight Getting Started Manual or [How To Start and Connect Automatically](#) for more information.



Replace a Case

You can replace an existing case. This is most useful when you wish to load a new dataset without having to stop and re-start the client. To replace a case:

Using simple File->Open dialog method:

Do the same thing you do for adding a case, but select the **Replace currently loaded data** toggle.

Using File->Data (reader) dialog method

1. Select the case you wish to replace in the Case menu (Case > *casename*).

2. Select Case > Add, Replace, Delete... to open the data reader File Selection dialog.

3. If the Case section is not open, click the turndown.

4. Click Replace...

You will be asked to confirm the replacement. If confirmed, the server associated with the selected case is terminated and the EnSight client will now start the connection process for the new server. If your original connection was automatic, the new server will be started automatically. If your original connection was manual, you will have to manually start another server. You can follow the progress of the connection in the Message area. See [How To Start and Connect Automatically](#) for more information.

Delete a Case

To delete a case:

1. Select the case you wish to delete in the Case menu (Case > *casename*).

2. Select Case > Add, Replace, Delete... to open the data reader File Selection dialog.

3. If the Case section is not open, click the turndown.

4. Click Delete...

You will be asked to confirm the deletion. If confirmed, the server associated with the selected case is terminated.

Displaying Parts by Case

By default all parts from all cases are displayed in the Main Parts list and they are displayed in a hierarchical manner by case. There are several different ways to show or not show things in the list. These are controlled by the Sort... button under the list. See [How To... Introduction to Part Creation](#) for more details on viewing the parts list.

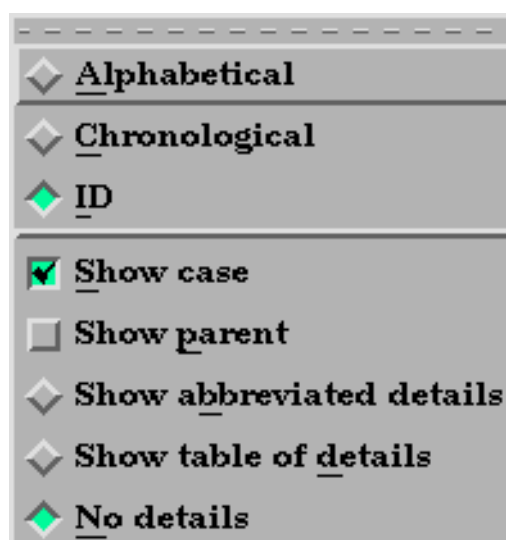
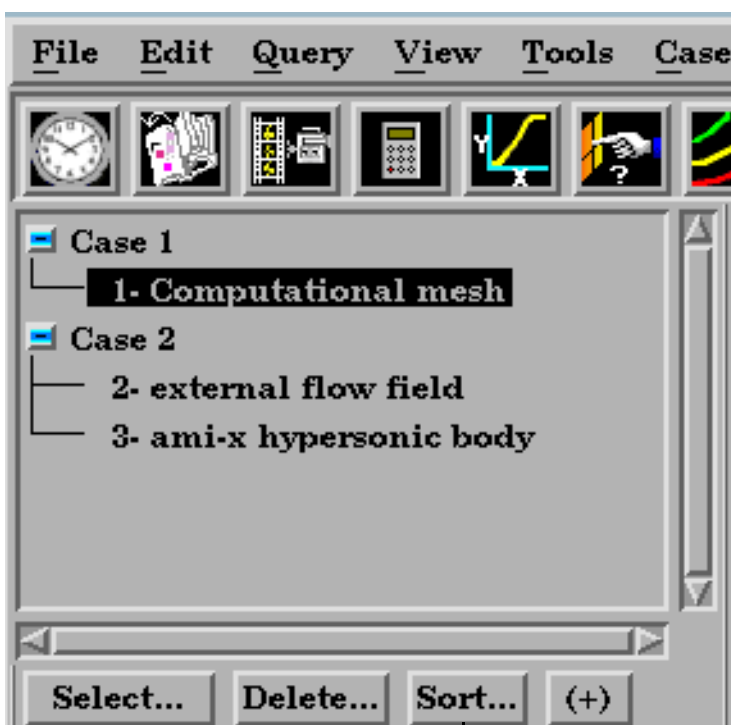



Case Viewport Display

One of the chief advantages of the case feature is the ability to perform side-by-side comparisons of different datasets. One way to do this is to display each case in a separate viewport. To do this:

1. Create as many additional viewports as you need to display your cases. See [How To Define and Change Viewports](#) for more information.
2. Select the case whose parts you wish to display only in certain viewports in the Case menu (Case > *casename*).
3. Select Case > Viewport Visibility...
4. Click in the desired viewport to enable or disable display of the selected case. Black means the selected case is not displayed in the viewport, green means that it is displayed.

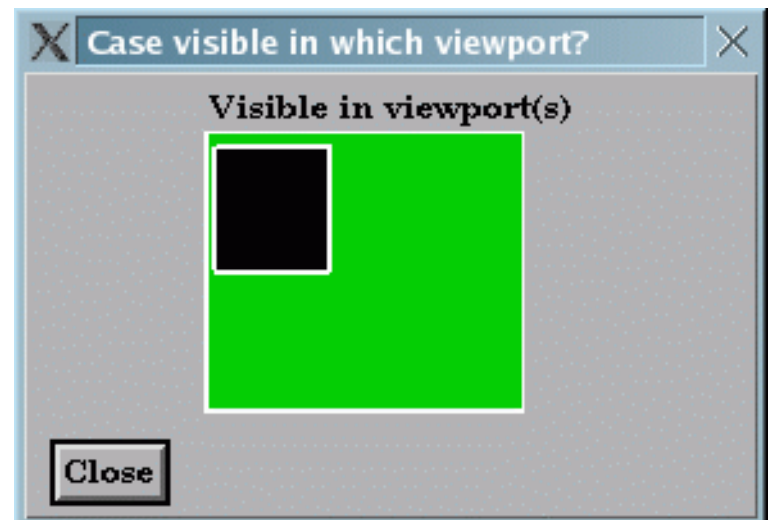

ADVANCED USAGE

EnSight's cases capability has also been used to achieve coarse-grained parallelism for very large datasets by partitioning a mesh into blocks and reading each block into a different case. Each case can run on different machines or on different CPUs of a multiprocessor host. Since the EnSight client places the geometry from the different cases in the same coordinate system, the blocks are effectively "stitched" back together for viewing. Operations such as clipping and isosurface calculation are then automatically performed in parallel. However, since there is no communication between the servers (in the current release) you cannot trace particles originating in one block and expect them to cross a block boundary into a different block. (It should be noted that EnSight's server-of-server capability is an alternate, and usually better way to do parallel operations on a model.)

OTHER NOTES

When you perform an archive operation, a binary dump file is produced for *each* active server (case). The archive information file contains details about the cases and can be used to restart the EnSight client as well as all servers active when the archive was performed. See [How To Save and Restore an Archive](#) for more information.

SEE ALSO

User Manual: [Case Menu Functions](#)



INTRODUCTION

From its inception, EnSight has been used extensively to postprocess time-varying or transient data. In many cases, dynamic phenomena can only be understood through interactive exploration as a transient case is animated.

EnSight handles all types of transient data. All variables as well as mesh coordinates and connectivity can vary over time. The rate at which variables (or the mesh) change can differ (supported through the EnSight Gold and EnSight6 Case data format only).

EnSight can postprocess transient data in many ways. The **Solution Time** Quick Interaction area lets you easily set the current time step, step through time (manually or automatically), or restrict the range of time to a region of interest. You can perform **query operations** to extract information over time. You can use the **flipbook** capability to create an on-screen animation of your data changing over time and continue to interact with it during animation playback. EnSight's **keyframe animation** capability can be used to create high-quality video animations of transient data.

This article covers reading transient data into EnSight.

BASIC OPERATION

Reading transient data into EnSight is essentially the same as reading static data (see [How To Read Data](#) for more information). By default, the *last* time step will become the current time step. This behavior is based on the assumption that the last step will contain the largest dynamic range of the variable data so that variable palettes will be initialized properly. However, you can override this by clicking the Specify Starting Time Step toggle and entering the desired time step in the data reader File Selection dialog (File > Data (Reader)...).

For most data formats, the “results” file supplies the necessary time information, including number of steps, actual solution time at each step, and how to access the dynamic variable and geometry files. However, some formats supported by EnSight include this information in the same file that contains other geometry or variable data. The following table lists how transient data is specified for each format type.

Format Type		What File Contains Time Info?	Notes
Case	EnSight 6	file.case	Standard EnSight case file
	EnSight Gold	file.case	Standard EnSight case file
EnSight 5		file.res	Standard EnSight results file
ABAQUS		file.fil	
ABAQUS_ODB		file.odb	
ANSYS RESULTS		file.rst, file.rth, etc.	
Ansys Results (v8)		file.rst, file.rth, etc.	
AVUS			Does not handle transient data directly
AVUS Case		file.txt	AVUS text case file
CFF		file	
CFX-4		file.dmp	
CGNS		file.cgns	
ESTET			Does not handle transient data
ExodusIIgold		file.exo	
FAST UNSTRUCTURED		file.res. Can handle transient geometry as well as solution and function files.	Special FAST format results file. See FAST UNSTRUCTURED Results File Format
FIDAP NEUTRAL		file.fdtype	All time steps must be contained in the same neutral file (<i>i.e.</i> there is only one file, not one for every time step).
D_Fluent		file.cas, file.dat	
FLUENT UNIVERSAL		file.unv	Special FLUENT format results file. See FLUENT UNIVERSAL Results File Format



Format Type	What File Contains Time Info?	Notes
Special HDF5	file (each file contains one time value)	Special casefile containing number of files and the list of files to use.
LS-DYNA3D	file.d3plot	Can be all in one file or in a family of d3plot files.
Medina bif/bof	file.konfig	
Movie	file.res	Standard EnSight results file
MPGS 4.1	file.res	Standard EnSight results file
MSC/Dytran	file.arc files	Remember file.dat can be used to assemble multiple "parts" from multiple file.arc files.
Nastran OP2	file.op2	
N3S	file.res	N3S results file
NetCDF	file.ncase	
PLOT3D	file.res. Can handle transient geometry as well as solution and function files.	Special PLOT3D format results file. See PLOT3D Results File Format .
RADIOSS_4.x	file.anim	
SCRYU	file.pre	
Silo	file.silo or file.case	Multiple times can be in the file.silo file, or the file.case file can contain reference to multiple files and their times.
STL		Does not handle transient data
TECPLOT 7.x	file.plt	
Tecplot_ASCII	file.dat	
Vectis		
Other User Defined	varies with each reader	See How to Read User Defined

SEE ALSO

[How To Change Time Steps](#), [How To Animate Transient Data](#), [How To Query/Plot](#)

User Manual: [Flipbook Animation](#), [Query/Plot](#)



INTRODUCTION

ensight8 (with gold license key) has the capability of dealing with partitioned data in an efficient distributed manner by utilizing what we call a server-of-servers (SOS for short). An SOS server resides between a normal client and a number of normal servers. Thus, it appears as a normal server to the client, and as a normal client to the various normal servers.

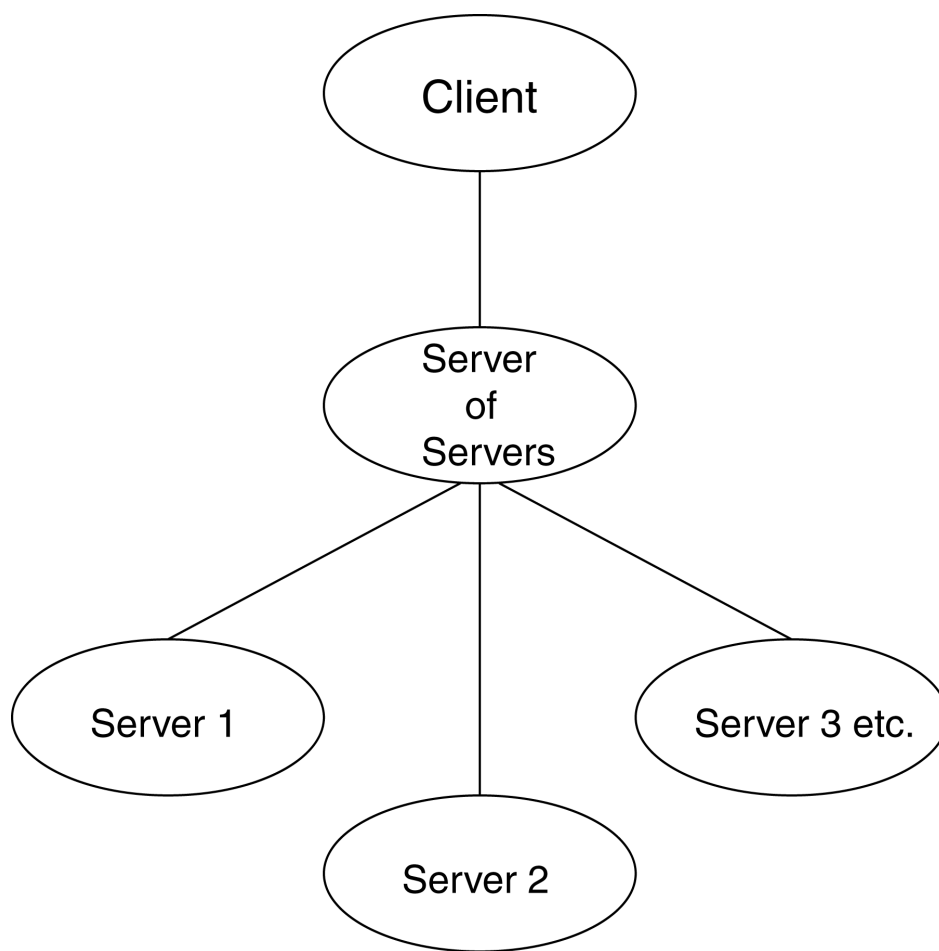

This arrangement allows for distributed parallel processing of the various portions of a model, and has been shown to scale quite well.

Currently, EnSight SOS capability is only available for EnSight5, EnSight6, EnSight Gold, Plot3d, and any EnSight User-Defined Reader data. (It is not directly available for Fidap Neutral, Fluent Universal, N3S, Estet, MPGS4, Movie, Ansys, Abaqus, or FAST Unstructured data.)

Please recognize that your data must be partitioned in some manner (hopefully in a way that will be reasonably load balanced) in order for this approach to be useful. (The exception to this is the use of the `auto_distribute` capability for structured data. This option can be used if the data is structured and is available to all servers defined. It will automatically distribute each portion of each structured block over the defined servers - without the user having to partition the data.)

(Included in the EnSight distribution is an unsupported utility that will take most EnSight Gold binary unstructured datasets and partition it for you. The source for this utility (called "chopper") can be found in the `$CEI_HOME/ensight80/unsupported/partitioner` directory.)

Note: If you do your own partitioning of data into EnSight6 or EnSight Gold format, please be aware that each part must be in each partition - but, any given part can be "empty" in any given partition. (All that is required for an empty part is the "part" line, the part number, and the "description" line.)

You should place each partitioned portion of the model on the machine that will compute that portion. Each partitioned portion is actually a self contained set of EnSight data files, which could typically be read by a normal client - server session of EnSight. For example, if it were EnSight gold format, there will be a casefile and associated gold geometry and variable results file(s). On the machine where the EnSight SOS will be run, you will need to place the sos casefile. The sos casefile is a simple ascii file which informs the SOS about pertinent information needed to run a server on each of the machines that will compute the various portions.



The format for this file is as follows: (Note that [] indicates optional information, and a blank line or a line with # in the first column are comments.)

FORMAT (Required)
type: master_server datatype (Required)
where: **datatype** is required and is one of the formats of EnSight's internal readers (which use the Part builder), namely:
gold ensight6 ensight5 plot3d
 or it can be the string used to name any of the user-defined readers.
 Note: For user-defined readers, the string must be exactly that which is defined in the USERD_get_name_of_reader routine of the reader (which is what is presented in the Format pulldown of the Data Reader dialog).
 If **datatype** is blank, it will default to EnSight6 data type.

[auto_distribute: on/off] (Optional for structured, Ignored for unstructured)
 For structured data only, EnSight will automatically distribute data to the servers specified below if this option is present and set to "on". This will require that each of the servers have access to the same data (or identical copies of it).

[plot3d_iblanked: true/false] (Required only if **datatype** is plot3d)
[plot3d_multi_zone: true/false] (Required only if **datatype** is plot3d)
[plot3d_dimension: 1d/2d/3d] (Required only if **datatype** is plot3d)
[plot3d_source: asciicbin/fortranbin] (Required only if **datatype** is plot3d)
[plot3d_grid_double: true/false] (Required only if **datatype** is plot3d)
[plot3d_results_double: true/false] (Required only if **datatype** is plot3d)

where: iblanking, multi_zone, dimension, source type, grid file double precision, and results file double precision information should be provided. If it is not provided, it will default to the following (which is likely not to be correct):

```
plot3d_iblanked:      false
plot3d_muti_zone:    false
plot3d_dimension:    3d
plot3d_source:       cbin
plot3d_grid_double:  false
plot3d_results_double: false
```

NETWORK_INTERFACES (**Note: This whole section is optional.** It is needed only when more than one network interface to the sos host is available and it is desired to use them. Thus, distributing the servers to sos communication over more than one network interface)

number of network interfaces: num (Required - if section used)
where: **num** is the number of network interfaces to be used for the sos host.
network interface: sos_network_interface_name_1 (Required - if section used)
network interface: sos_network_interface_name_2 (Required - if section used)
 ⋮
network interface: sos_network_interface_name_num (Required - if section used)

SERVERS (Required)
number of servers: num (Required)
where: **num** is the number of servers that will be started and run concurrently.

#Server 1 (Comment only)
machine id: mid (Required)
where: **mid** is the machine id of the server.

executable: /.../ensight8.server (Required, must use full path)
[directory: wd] (Optional)
where: **wd** is the working directory from which ensight8.server will be run

[login id: id] (Optional)
where: **id** is the login id. Only needed if it is different on this machine.

[data_path: /.../dd] (Optional)
where: **dd** is the directory where the data resides. Full path must be provided if you use this line.





casefile: <i>yourfile.case</i>	(Required, but depending on format, may vary as to whether it is a casefile, geometry file, neutral file, universal file, etc. Relates to the first data field of the Data Reader Dialog.)
[resfile: <i>yourfile.res</i>]	(Depends on format as to whether required or not. Relates to the second data field of the Data Reader Dialog.)
[measfile: <i>yourfile.meas</i>]	(Depends on format as to whether required or not. Relates to the third data field of the Data Reader Dialog.)
[bndfile: <i>yourfile.bnd</i>]	(Depends on format as to whether required or not. Relates to the fourth data field of the Data Reader Dialog.)

--- Repeat pertinent lines for as many servers as declared to be in this file ---

BASIC OPERATION

To use Server of Servers, you must:

1. Partition your data, and distribute it (or make it available) to the various machines on which you will run servers. (Or if you have structured data, you can use the `auto_distribute` option in the `sos` casefile.)
2. Create the `sos` casefile, which defines the server machines, the location of server executables on those machines, and the name and location of the partitioned data for the servers.
3. Use `ensight8.sos` in place of `ensight8.server`, and provide it with the `sos` casefile.

Example SOS Casefile

This example deals with a EnSight Gold dataset that has been partitioned into 3 portions, each running on a different machine. The machines are named `joe`, `sally`, and `bill`. The executables for all machines are located in similar locations, but the data is not. Note that the optional `data_path` line is used on two of the servers, but not the third.

```

FORMAT
type: master_server gold

SERVERS
number of servers: 3

#Server 1
machine id: joe
executable: /usr/local/bin/ensight80/bin/ensight8.server
data_path: /usr/people/john/data
casefile: portion_1.case

#Server 2
machine id: sally
executable: /usr/local/bin/ensight80/bin/ensight8.server
data_path: /scratch/sally/john/data
casefile: portion_2.case

#Server 3
machine id: bill
executable: /usr/local/bin/ensight80/bin/ensight8.server
casefile: /scratch/temp/john/portion_3.case

```

If we name this example `sos` casefile - "`all.sos`", and we run it on yet another machine - one named `george`, you would want the data distributed as follows:

On <code>george</code> :	<code>all.sos</code>
On <code>joe</code> (in <code>/usr/people/john/data</code>):	<code>portion_1.case</code> , and all files referenced by it.
On <code>sally</code> (in <code>/scratch/sally/john/data</code>):	<code>portion_2.case</code> , and all files referenced by it.
On <code>bill</code> (in <code>/scratch/temp/john</code>):	<code>portion_3.case</code> , and all file referenced by it.

By starting EnSight with the `-sos` command line option (which will autoconnect using `ensight8.sos` instead of `ensight8.server`), or by manually running `ensight8.sos` in place of `ensight8.server`, and providing `all.sos` as the casefile to read in the Data Reader dialog - EnSight will actually start three servers and compute the respective portions on them in parallel.





So, one could do the following (after preparing the all.sos file):

On "george", run the client and the sos by invoking the ensight8 script in a shell window (non-windows) or Command Prompt window (windows), like:

```
george>> ensight8 -sos
```

Or one could run the client on the "myclient" machine, telnet (or equivalent) into the "george" machine and run the sos there, by using the following commands:

If "myclient" is a non-windows machine:	
In a window on "myclient":	In a window that is telneted into the "george" machine:
myclient>> ensight8.client -cm	If "george: is a non-windows machine: george>> ensight8.sos -c myclient
	If "george is a windows machine: george>> ensight8_sos -c myclient

:

If "myclient" is a windows machine:	
In a Command Prompt window on "myclient":	In a Command Prompt window that is telneted into the "george" machine:
myclient>> ensight8_client -cm	If "george: is a non-windows machine: george>> ensight8.sos -c myclient
	If "george is a windows machine: george>> ensight8_sos -c myclient

In either case, you would enter the all.sos command as the file to read in the Data Reader dialog once EnSight is up and connected. And the servers on "joe", "sally", and "bill" would be started and used automatically.

Optional NETWORK_INTERFACES section notes

If the machine named george had more than one network interface (say it had its main one named george, but also had one named george2), we could add the section shown below to our casefile example:

```
NETWORK_INTERFACES
number of network interfaces: 2
network interface: george
network interface: george2
```

This would cause machine joe to connect back to george, machine sally to connect back to george2, and machine bill to connect back to george. This is because the sos will cycle through its available network interfaces as it connects the servers. Remember that this is an optional section, and most users will probably not use it. Also, the contents of this section will be ignored if the -soshostname command line option is used.



Example SOS Casefile for PLOT3D, Using auto_distribute

This example shows a plot3d dataset (post.x and post.q) that has not been partitioned, but is on an nfs mounted disk available to each server machine. EnSight will distribute the data to the 3 servers defined. IO will not necessarily be great since each server will be reading from the same file, but execution will be enhanced by the partitioning. We will use the same machines used in the previous example.

FORMAT

```
type: master_server plot3d
auto_distribute: on
plot3d_iblanked: true
plot3d_multi_zone: false
plot3d_dimension: 3d
plot3d_source: cbin
plot3d_grid_double: false
plot3d_results_double: false
```

SERVERS

```
number of servers: 3
```

#Server 1

```
machine id: joe
executable: /usr/local/bin/ensight80/bin/ensight8.server
data_path: /scratch/data
casefile: post_x
resfile: post.q
```

#Server 2

```
machine id: sally
executable: /usr/local/bin/ensight80/bin/ensight8.server
data_path: /scratch/data
casefile: post.x
resfile: post.q
```

#Server 3

```
machine id: bill
executable: /usr/local/bin/ensight80/bin/ensight8.server
data_path: /scratch/data
casefile: post.x
resfile: post.q
```

SEE ALSO

[How To Read Data](#)

[How To Read User Defined](#)

User Manual: [Server-of-Server Casefile Format](#)



Read User Defined

INTRODUCTION

EnSight provides a mechanism for users to write their own readers and have the code automatically link and execute at run-time (using a shared library). Since this is a capability which is somewhat subject to change, usage information is best provided in README files in the EnSight Distribution. See the README files in `$CEI_HOME/ensight80/src/readers/` for details. A couple of sample readers, as well as the code for several actual readers are also provided below this directory.

Additionally, a `udr_checker.c` file is provided in `$CEI_HOME/ensight80/src/readers/checker` which can be used to debug your User-defined reader before using it with EnSight. See the README in this directory.

OTHER NOTES

When starting EnSight (`ensight8` or `ensight8.server`), you use the command line option “`-readerdbg`” to echo user defined reader loading status. This will allow you to see what readers are actually being loaded.

Set the environment variable `ENSIGHT8_READER` to point to the path where additional user defined readers exist.

SEE ALSO

[How To Read Data](#)





Do Structured Extraction

INTRODUCTION

When building parts from the Data Part Loader dialog for structured parts (EnSight6 structured parts, EnSight gold structured parts, PLOT3D parts), there is some flexibility in what is actually extracted. If the model contains iblanking, then you have control over which iblanking domain to use, namely Inside, Outside (blanked out), or All (which ignores the iblanking). If no iblanking in the model, the domain is All by default. You can extract all or portions of zones at original or coarser resolutions, do the extractions on single or multiple zones, extract planes at every delta value within a zone, etc.

BASIC OPERATION

When extracting the domain parts, whether iblanked or not, some (but definitely not all combinations) of the options include:

Extracting a complete zone at original resolution,

1. Select the structured zone desired.

Optionally you can change the domain and provide a part description.

2. Hit the Create/Load from selected button.

The part will be created and shown in the graphics window. In the example below, it is shown in border representation mode.

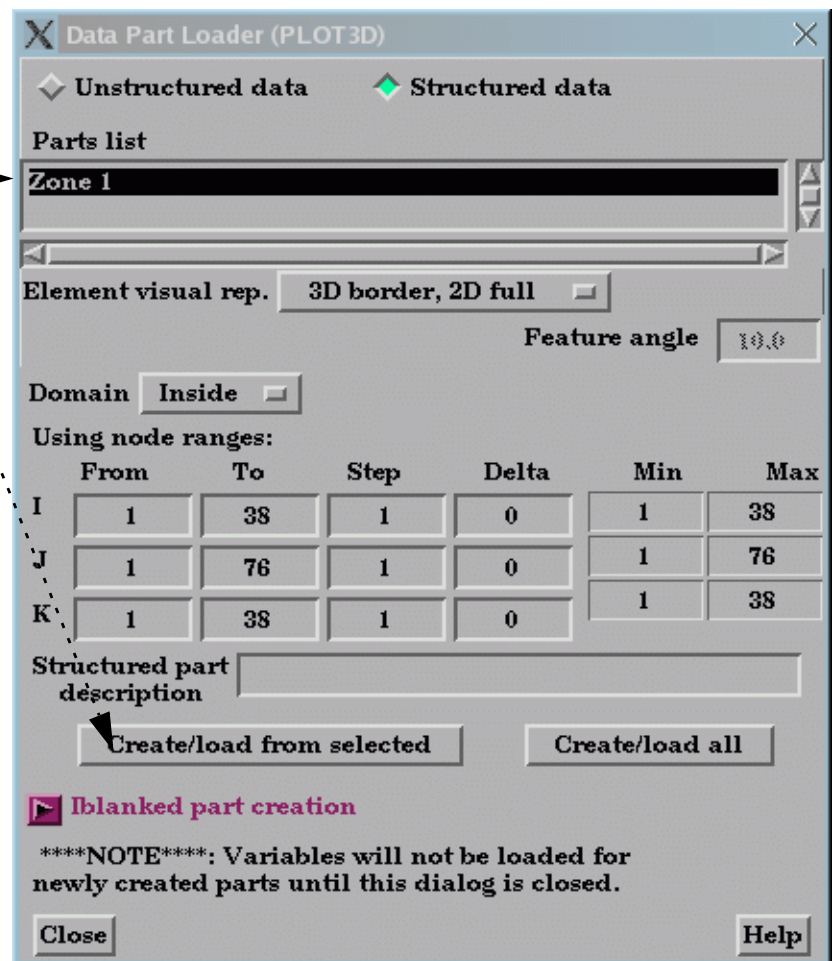
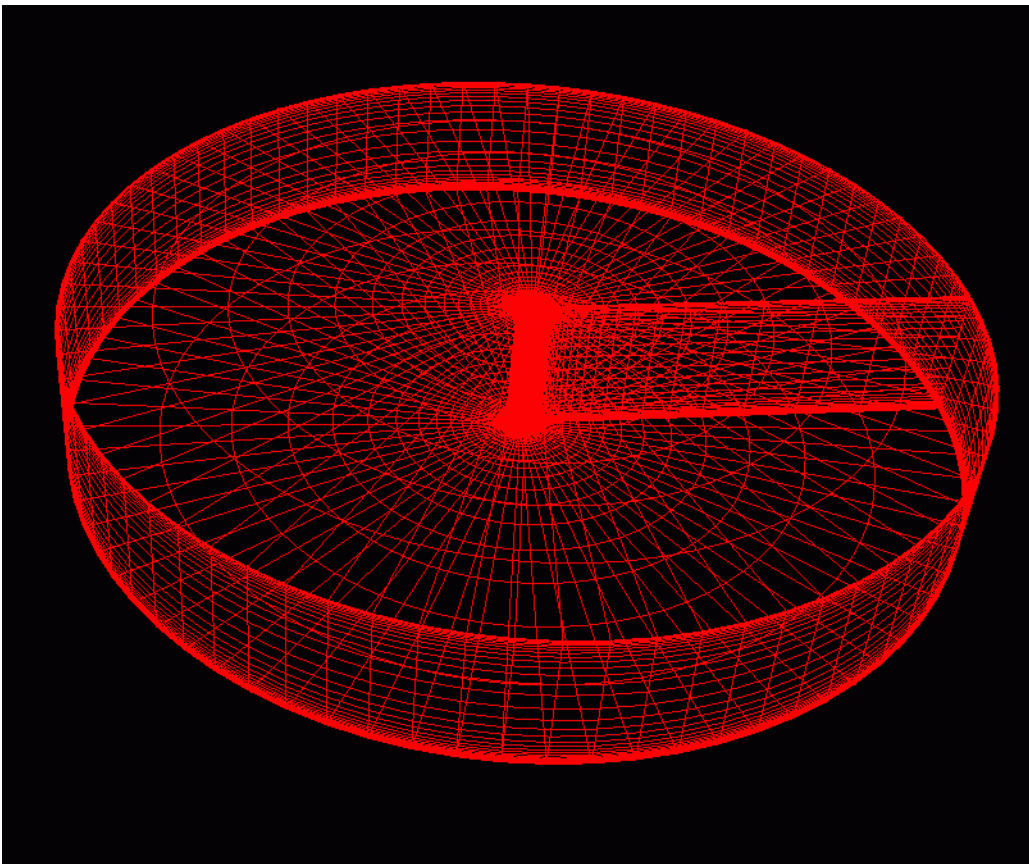



Extracting a complete zone at coarser resolution,

1. Select the structured zone desired.

Optionally you can change the domain and provide a part description.

2. Modify the Step values.

These should be positive integer values. A step of two means to deal with every other plane, a step of four means every fourth plane, etc.

3. Hit the Create/Load from selected button.

The part will be created and shown in the graphics window. In the example below, it is shown in border representation mode. Note that it is considerably coarser than the previous because step values of 2, 4, and 5 were used in the ijk directions respectively.

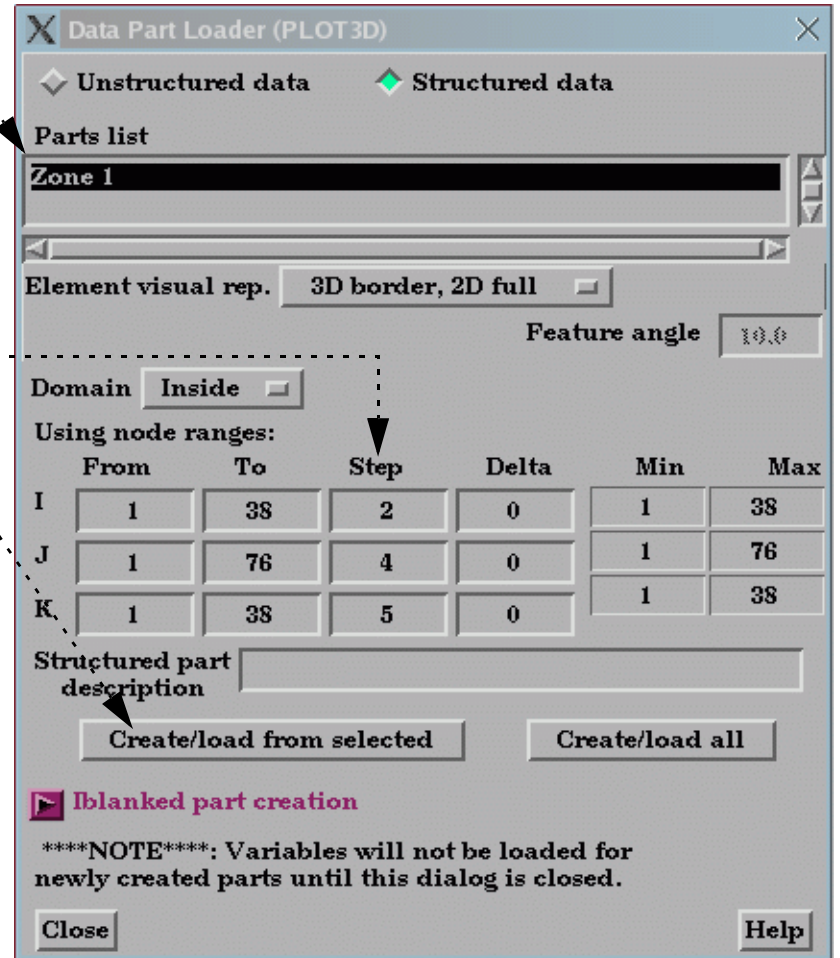
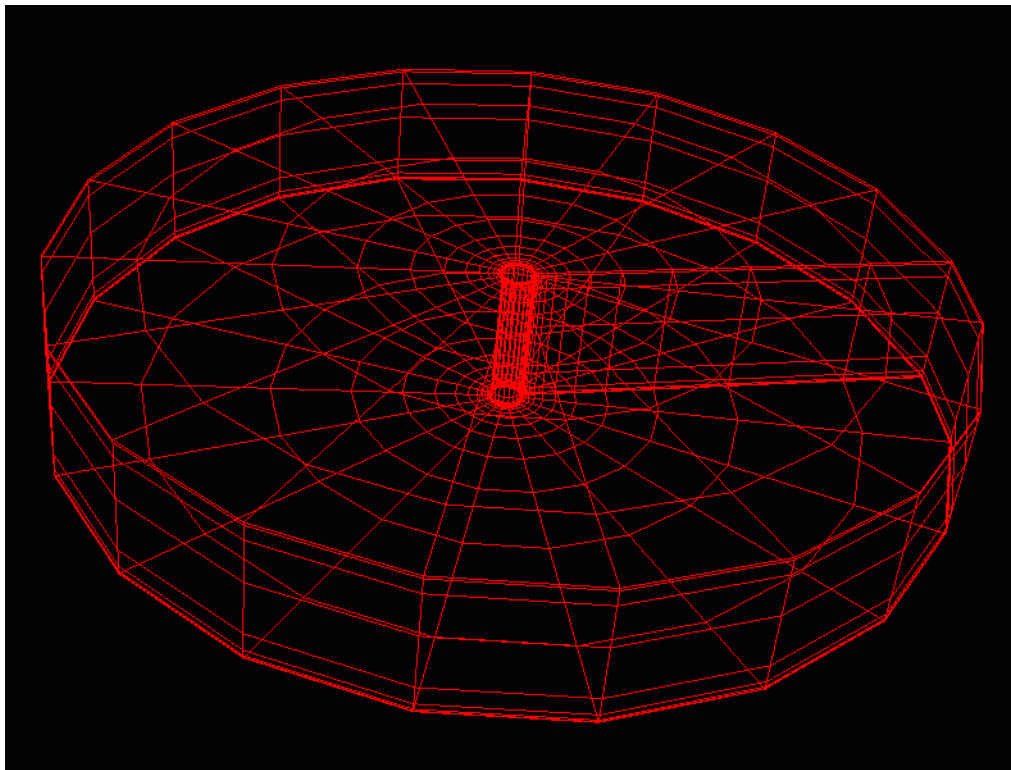



Extracting portions of a zone,

1. Select the structured zone desired.

Optionally you can change the domain and provide a part description.

2. Modify the From and To values.

These can be anything between the ranges shown in the Min and Max columns. By default they will be the entire range, but you can modify them.

3. Hit the Create/Load from selected button.

The part will be created and shown in the graphics window. In the example below, it is shown in border representation mode. Note that you now get a portion instead of the whole. Note also that we got original resolution because we set step values back to one. The step values can be other than one, and your portion will be at the coarser resolution.

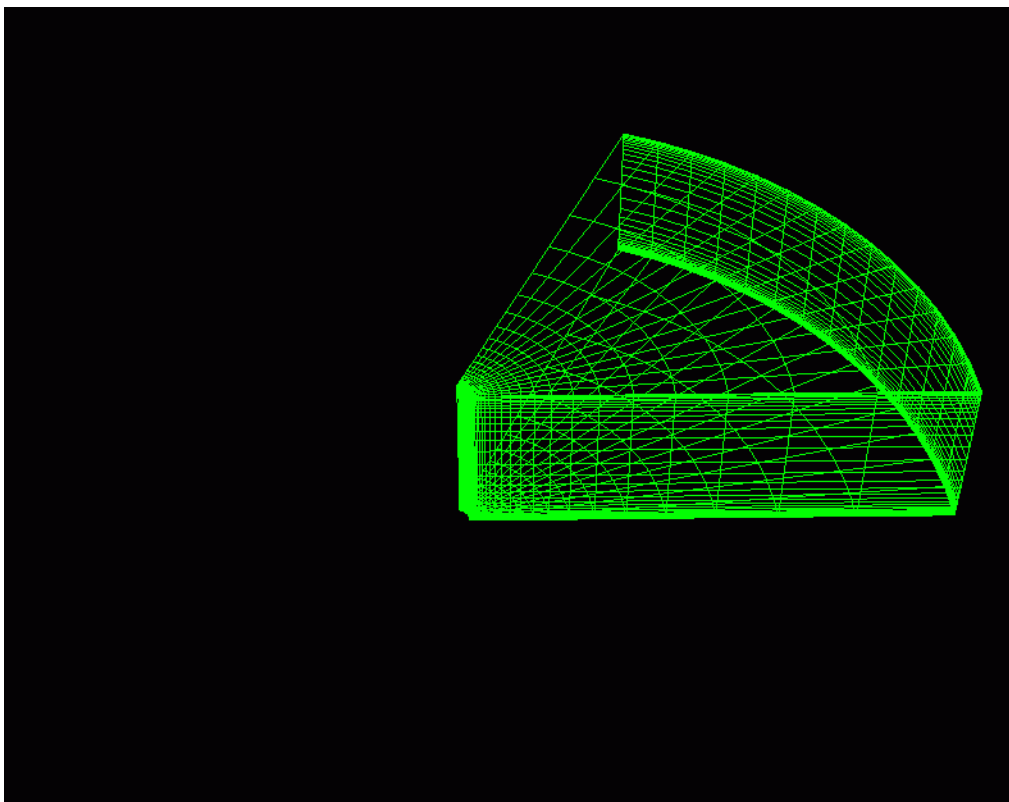
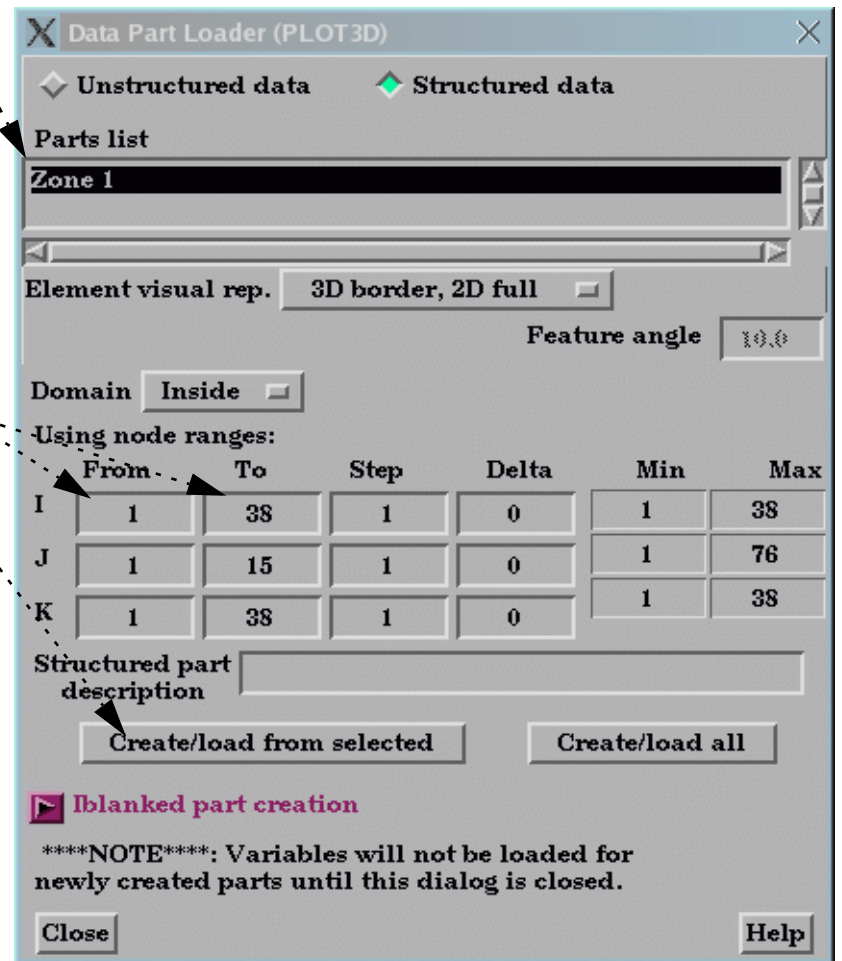



Extracting multiple planes within the same zone (these become unstructured),

1. Select the structured zone desired.

Optionally you can change the domain and provide a part description.

2. Modify the From and To values so that one dimension is a plane.

One of I, J, or K must have the same values for both From and To - indicating a plane in the other two dimensions.

3. Enter a value in the Delta field for the dimension that is a plane.

Only one of the Delta fields may be non-zero, and it must be one where the From and To values are the same.

4. Hit the Create/Load from selected button.

The part will be created and shown in the graphics window. In the example below, it is shown in border representation mode. Note that you now get an IK surface at J = 1, 6, 11, 16, 21, 26, ...

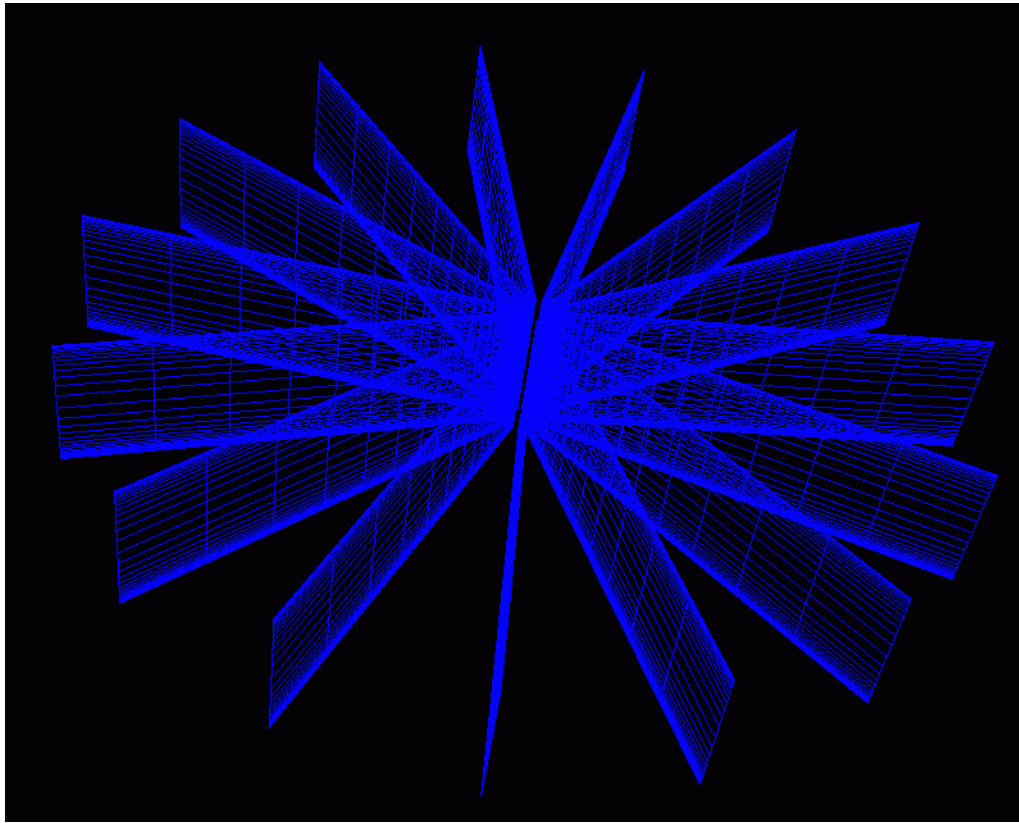
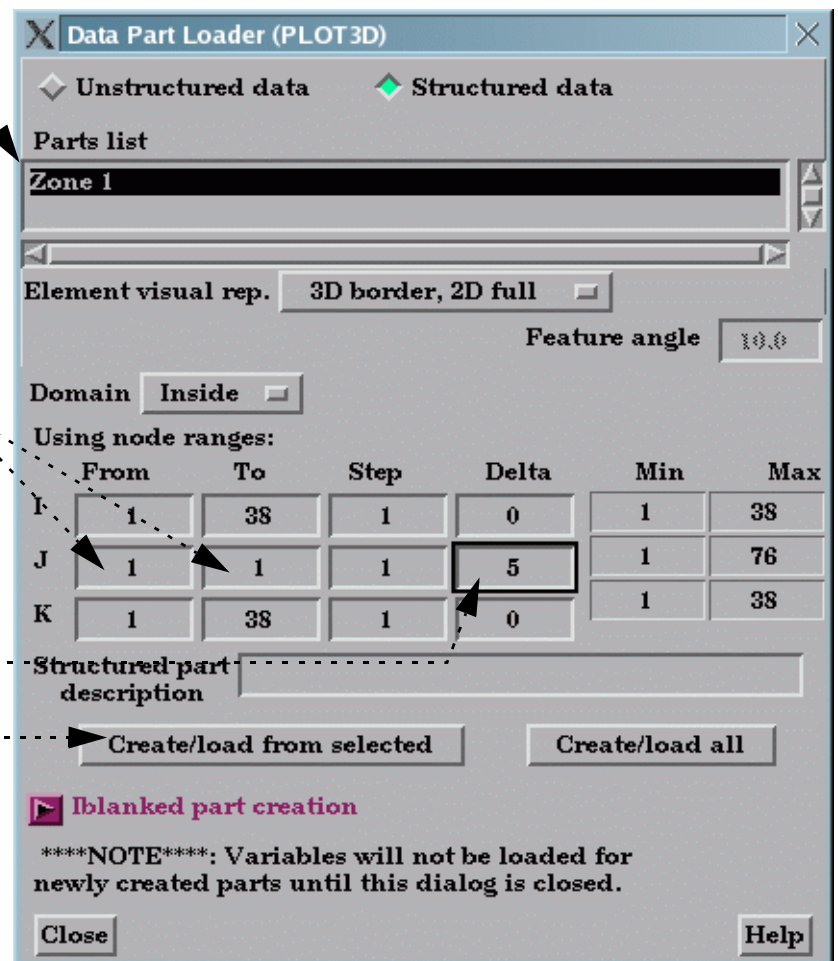

How To ... Do Structured Extraction



Extracting the same portions over multiple parts,

1. Select the structured zones desired.

Optionally you can change the domain

2. Modify the From and To values.

These can be anything between the ranges shown in the Min and Max columns (which will now be the min and max of all parts selected). By default they will be the entire range, but you can modify them. Additionally, "-1" is a valid entry, indicating the last plane. Minus numbers are ways to specify the plane from the max back toward the min, thus -2 equals the next to last plane. (Note: Zero is treated the same as -1)

3. Hit the Create/Load from selected button or the Create/load all button.

In this example, 4 parts will be created, and they will each be the full extent IK plane at J = 1 for each of the four zones. Note that the IK ranges can actually vary per part because the max is specified, but each zone may be less than the max.

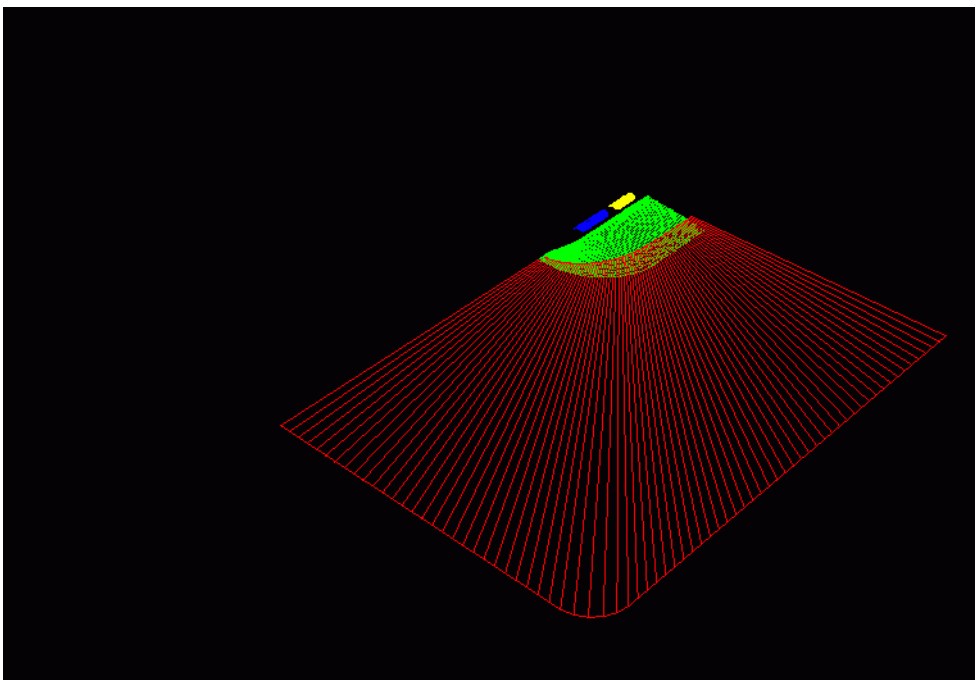

In our example, we then changed From and To to be "0", thus extracting the last plane in each zone. Note the image below. The image at the right includes complete zones that were extracted, but shown in feature angle representation so you get the feel of the complete zone.

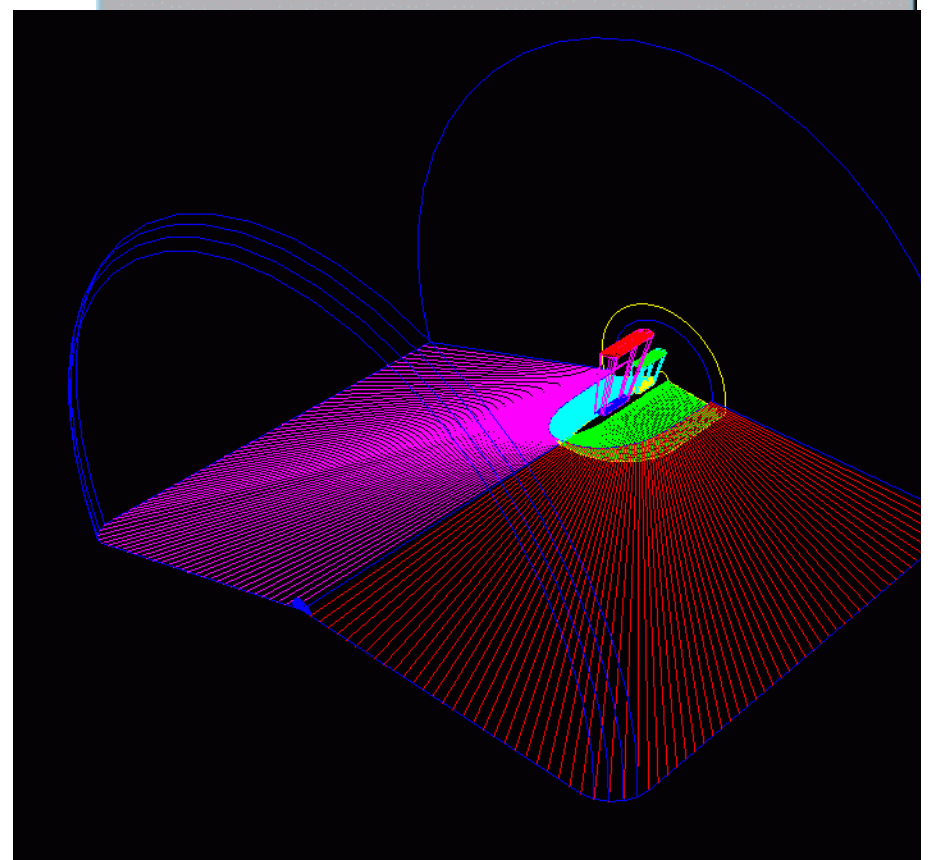
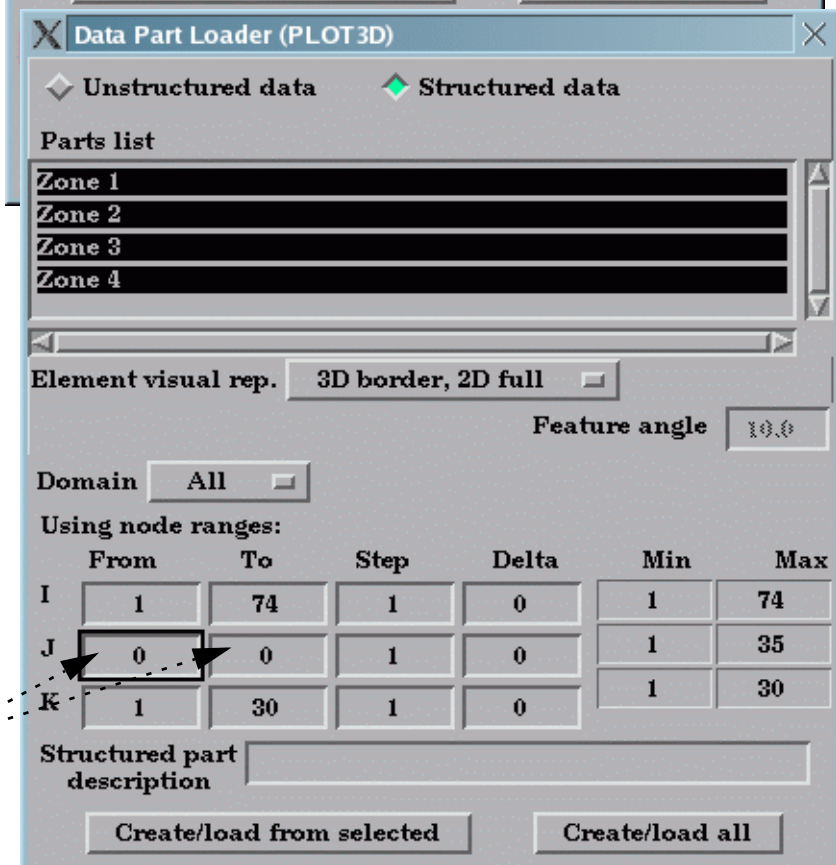
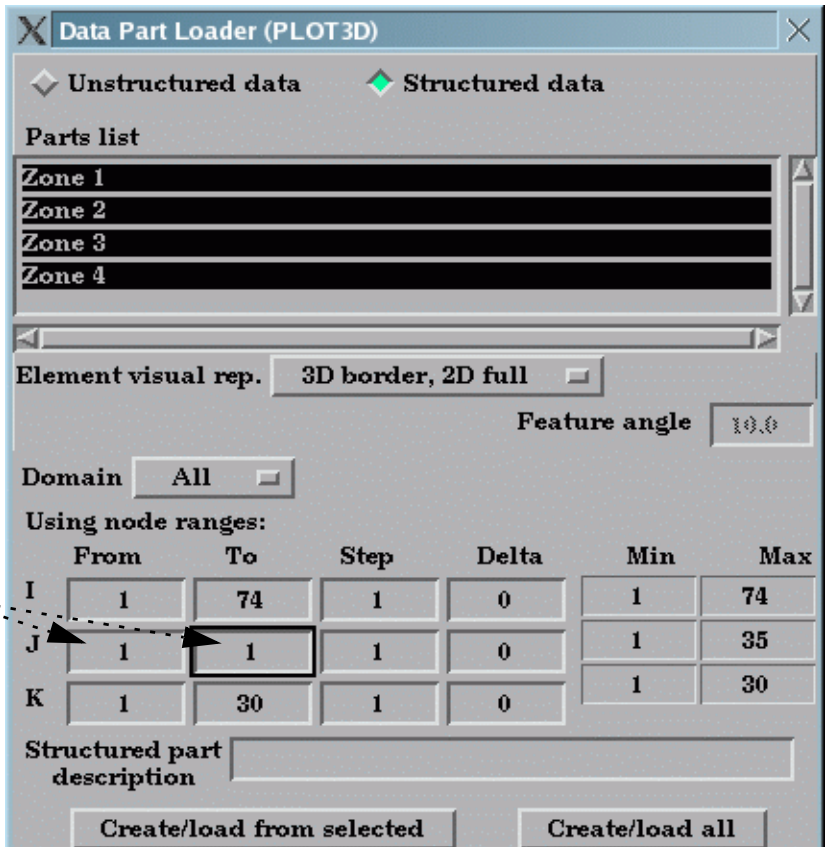
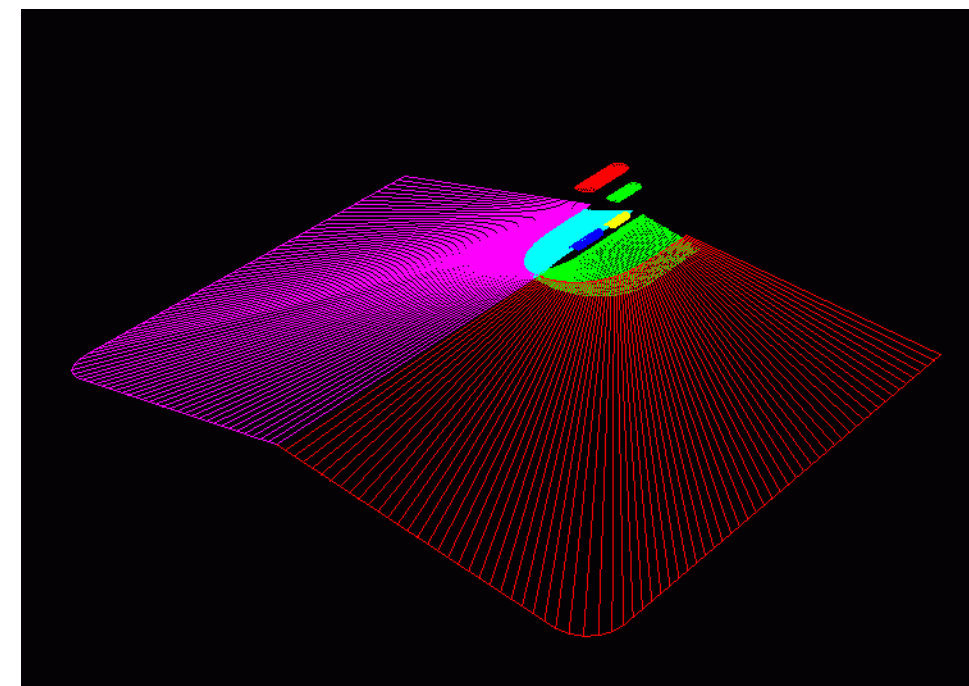



Extracting unstructured iblanked parts.

1. Select the structured zones desired.

Optionally you can change the Domain, From, To, and Step values.

2. Hit the Create/Load from selected button.

In this example, 4 parts will be created, and they will each be the full extents at original resolution. Iblanking for the domain will be ignored.

3. Open the Iblanked Part Creation turndown.

4. Select from the domain parts that you have previously created.

5. Select the iblanking value to use.

Optionally you can specify your own name for the part that will be created.

6. Hit the Create and Load Iblanked Unstructured Part button.

This will create an unstructured part consisting of the elements which have the selected iblank value from the selected parts.

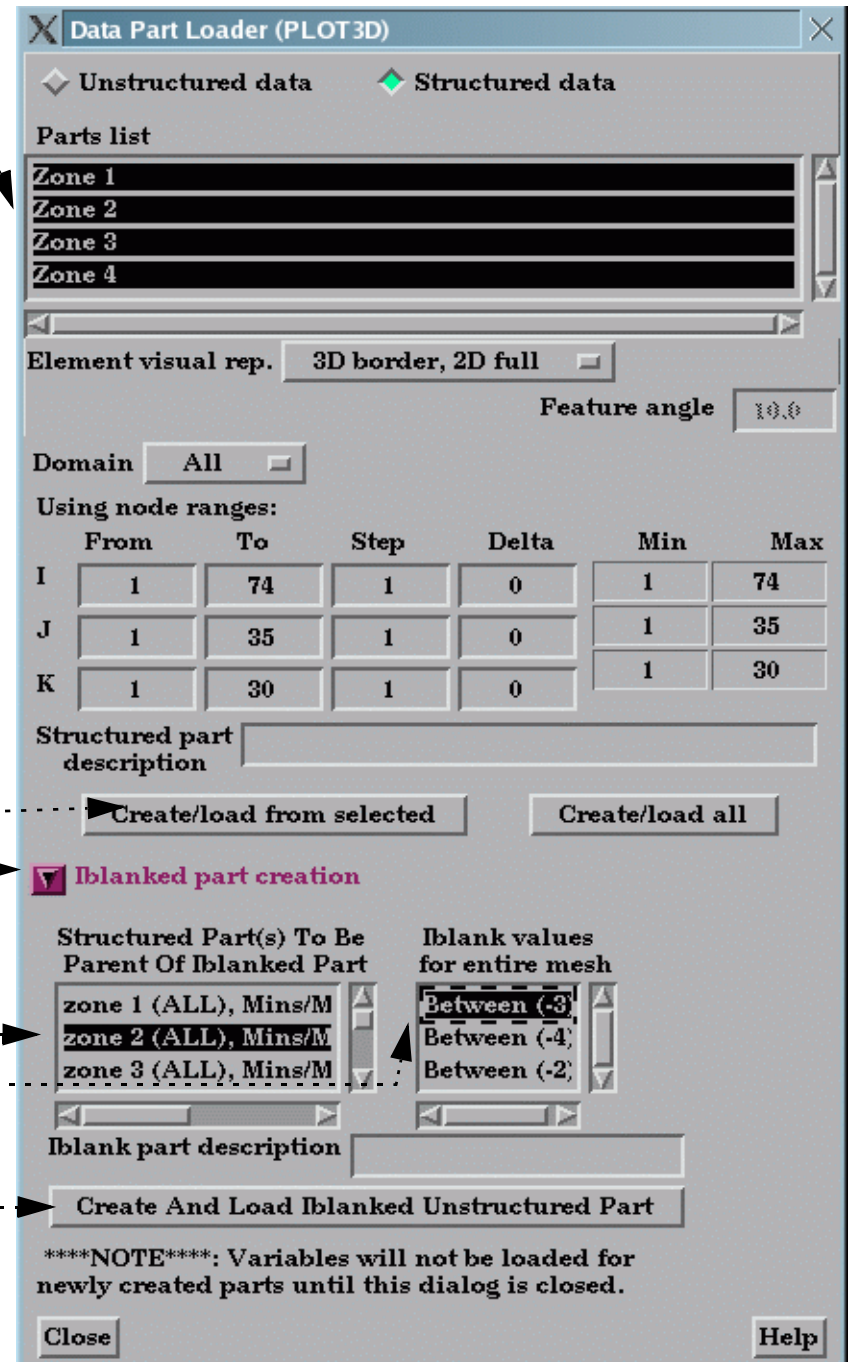

SEE ALSO

[How To Read Data](#)

User Manual: [Using Node Ranges:](#)



Save or Output
Save or Restore an Archive

INTRODUCTION

EnSight command files are useful for restoring the system to a state reached in a previous session. However, restoring a long session dealing with large files can be a tedious process. Fortunately, EnSight provides an archiving mechanism that saves only the current state of the system, rather than the entire history of a session.

This capability is useful not only for large data files with several active variables, but also for saving a standard starting point for sessions. In the initial session, geometry can be loaded, variables activated, a good viewpoint selected, and an archive written. Subsequent sessions take advantage of this investment by merely loading the archive (which can be done as you start EnSight from the command line).

The client and server each write separate binary files containing the complete current state of the respective processes. Since these files are binary, they can be quickly written and restored. Note that an archive only contains information resident in either client or server memory at the time of the archive. No information is available for variables that were inactive or time steps other than the current. For this reason, you should never remove the original dataset and attempt to use the archive as a substitute (unless you know what you're doing).

IMPORTANT NOTE: Currently archive save/restore operations are not supported when running EnSight Server-of-Servers.

BASIC OPERATION

An EnSight archive consists of three files:

1. The Archive Information File. This file provides pointers to the client and server archive files as well as additional information required to load the archive. An example is given in the Advanced Usage section below.
2. The Client Archive file. This is the client's binary dump file.
3. The Server Archive file. This is the server's binary dump file.

Although each file has a default location, you can override the default during the archiving process.

Saving an Archive

1. Close all open EnSight windows *except* the main window.
2. Select **File > Save > Full Backup...** to open the **Save Full Backup Archive** dialog.

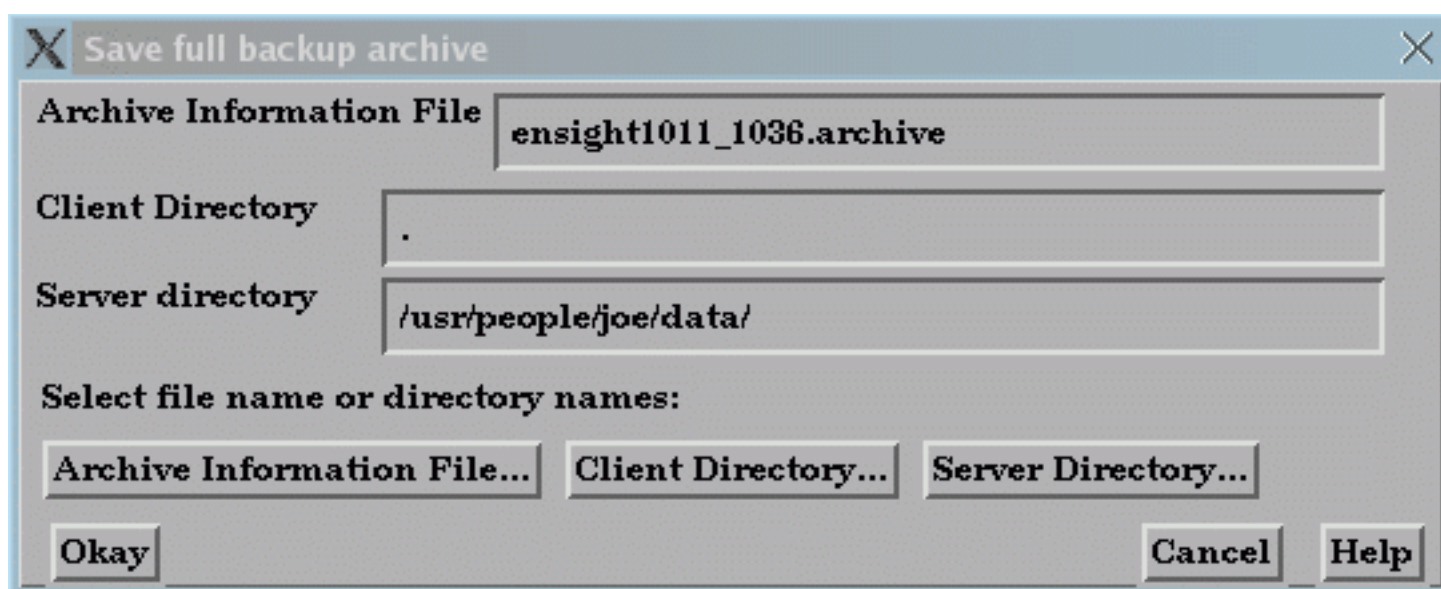

2. If desired, enter a new name for the Archive Information file. You can set the directory for the Archive Information File by clicking the Archive Information File... button to open a standard File Selection dialog.
3. If desired, select a directory for the client's binary dump file by either entering the directory in the Client Directory field or clicking the Client Directory... button to open a standard File Selection dialog.
4. If desired, select a directory for the server's binary dump file by either entering the directory in the Server Directory field or clicking the Server Directory... button to open a standard File Selection dialog.
5. Click Okay.



You also have the option of saving an archive as you exit EnSight.

1. Select **File > Quit...** to open the **Quit Confirmation** dialog.
2. Click the **Save Full backup Archive To** toggle and, if desired, enter a new name for the Archive information file.
3. Click **Yes** to save the archive and exit.

When saving an archive via the Quit Confirmation dialog, you do not have the option of specifying the directories for the archive files.

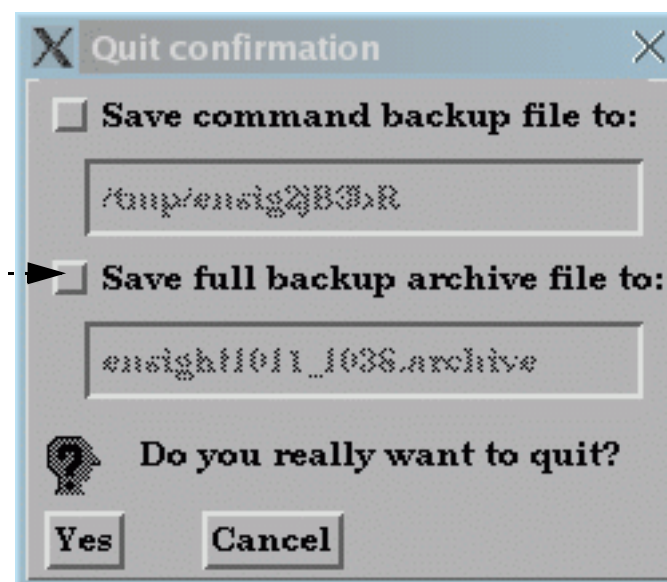

Restoring an Archive

You can restore an archive either as part of EnSight startup or during an active session. To load an archive on startup:

1. Use the “**-ar archive_info_file**” option when you start EnSight. For example,

```
% ensight8 -ar load.ar
```

where `load.ar` is an Archive Information file saved in a previous session.

To restore an archive during an active session:

1. Select **File > Restore > Full Backup...** to open the **File Selection** dialog.
2. Select the desired Archive Information file and click **Okay**.
3. If the original connection (when the archive was saved) was manual, you will need to manually restart the server.

ADVANCED USAGE

There are times when you may want to modify the contents of the Archive Information file. If you wish to use the archive on a different machine or change the location of the binary dump files, you can simply edit the file with a text editor. The following example shows the contents:

```

Date saved      Wed Apr  2 15:31:51 1997
Path to client's binary file client ./ensight0402_153151.clientbkup
comment        # server for Case 'Case 1'. **Warning Don't Modify The Internal Number**.
Case internal number case_internal_number 0
Case name      case_name Case 1
Connect type (auto or manual) case_connect_type auto
Server host machine case_connect_machine indigo2
Server executable case_connect_executable /usr/local/bin/ensight/server/ensight.server
Server data directory case_connect_directory /usr/people/joe/data
Alternate server login ID case_connect_login_id
Path to server's binary file server ./ensight_c1_0402_153151.serverbkup

```

Note that there will be a section for all the `case_` variables for *each* current case in the EnSight session. See [How To Load Multiple Datasets](#) for more information on cases.



OTHER NOTES

Important note! Archives are typically *not* upwardly compatible with new major – and some minor – releases of EnSight. For this reason, the complete current command file is also saved as part of the client's binary dump. If you attempt to restore an archive and EnSight determines that the archive is not compatible with the current release, the command file will be restored to a default location.

IMPORTANT NOTE: *Currently archive save/restore operations are not supported when running EnSight Server-of-Servers.*

SEE ALSO

User Manual: [Saving and Restoring a Full backup](#)



INTRODUCTION

Most powerful software systems have a built-in language that provides additional levels of power and functionality to complement and enhance a graphical user interface. EnSight is no exception. Any action that you can perform with the mouse or keyboard has a counterpart in the EnSight command language. A sequence of commands can be saved during a session to automate repetitive or tedious tasks. Command files can be automatically executed on EnSight startup to initialize the system to a desired state. Execution of command files can also be bound to keyboard keys for user-defined **macros**.

BASIC OPERATION

During an EnSight session, all actions are recorded and saved to a file known as the default command file. This file name typically starts with "ensigDAA" and is saved in /usr/tmp (unless you have redefined your TMPDIR environment variable). The default command file can be saved (and renamed) when exiting EnSight.

Recording Commands

To record a series of commands:

1. Select **File > Command...** to open the Command dialog.
2. Toggle the **Record** button on.
3. A File Selection dialog opens. Select the desired file to save commands to and click **Okay**.
4. When you wish to stop recording, toggle the **Record** button off.

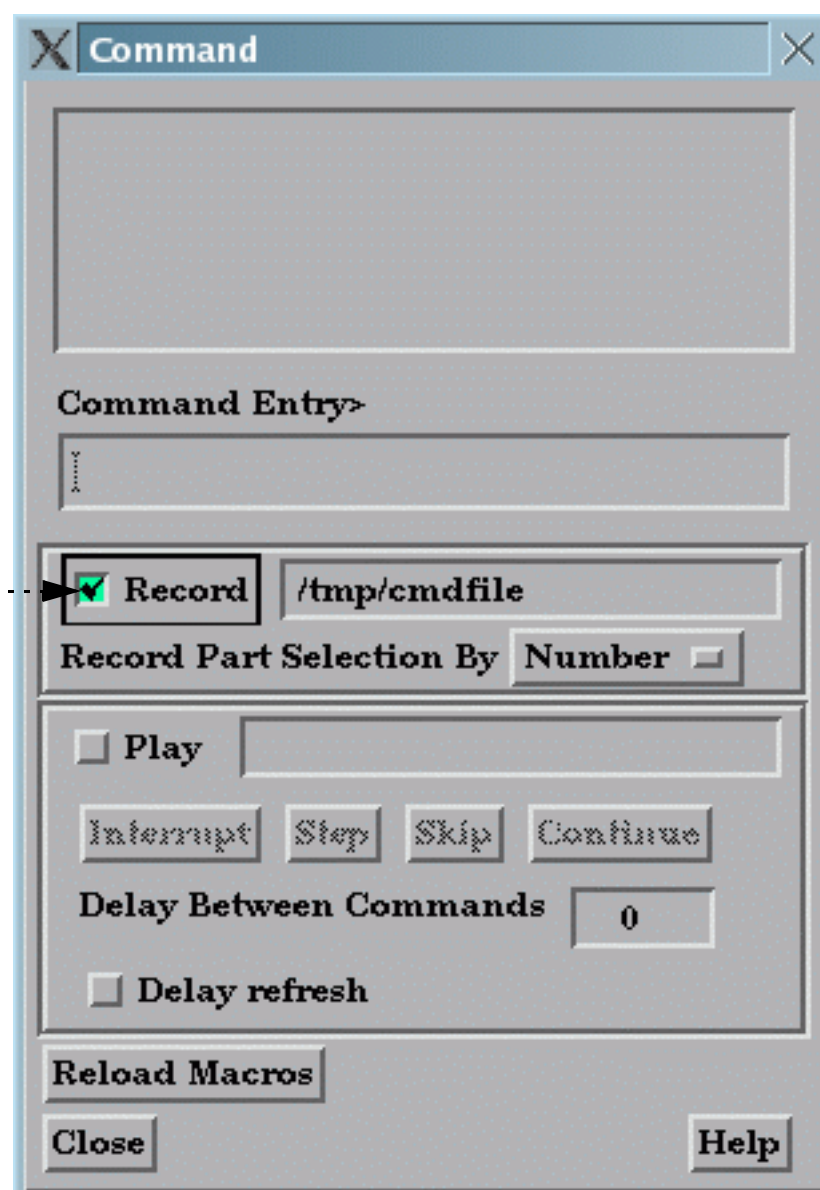



Playing a Command File

To replay a command file:

1. Select **File > Command...** to open the Command dialog.

2. Toggle the **Play** button on.

3. A **File Selection** dialog opens. Select the desired command file and click **Okay**.

You can control command execution by interrupting the playback. Once playback is stopped, you can single step through commands or even skip commands.

1. To stop command execution, click the **Interrupt** button.

2. To single-step through the commands, click the **Step** button.

3. To skip a command, click the **Skip** button.

4. To continue execution, click the **Continue** button.

Note that the next command to be executed is shown in the **Command Entry** field. You can also enter commands to be immediately executed in this field.

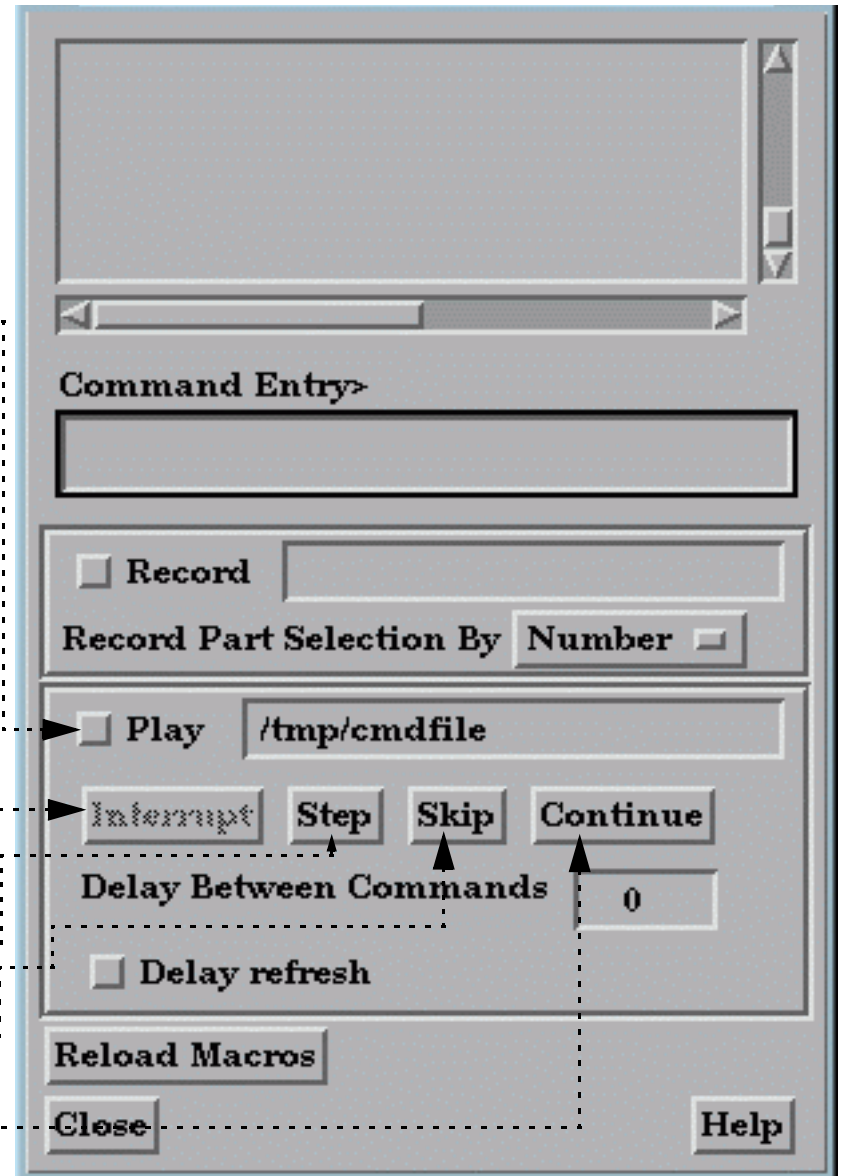

Playing a Command File on Startup

You can execute a command file as part of EnSight startup:

1. Use the **"-p command_file"** option when you start EnSight. For example,

```
% ensight8 -p redo.cmd
```

where **redo.cmd** is a command file saved in a previous session.

ADVANCED USAGE

Command files are simple ASCII text and can be edited with any text editor. To easily determine the command for a given action, open the Command dialog and watch the list at the top as you perform various operations. Keep in mind that the successful execution of some commands depends on the proper state existing at the time of execution. For example, creating a part when the parent part (as referenced by the part number) does not exist will cause an error.

Command files can be nested: if you have a file that performs a certain task, you can "call" that command file from another file with the `"play: filename"` command. An `"exit:"` command will cause EnSight to quit. An `"interrupt:"` command will cause the command file to pause execution and open the command dialog.

You can save the command file for the current session when you exit EnSight, or you can use **File > Save > Command** from this session... to save the commands up to that point.



OTHER NOTES

Command files provide an excellent method of documenting problems or potential bugs encountered during your use of EnSight. The command file can be transmitted to CEI electronically to help determine the nature of the problem.

SEE ALSO

[How To Define and Use Macros](#)

User Manual: [Command Files](#)



INTRODUCTION

The image displayed in the Graphics Window can be saved to disk or printed in a variety of formats: Apple PICT, JPEG, TIFF, PCL, PostScript (supporting image, “move-draw”, and EPS), RGB (Silicon Graphics), TARGA, CEI RGB with depth, EnVideo, MPEG1, MPEG2, AVI, and POVray.

If you wish to save a sequence of images (e.g. for a smooth animation or a transient data display), use EnSight’s [keyframe animation](#) facility.

BASIC OPERATION

1. Select File > Print/Save Image....

2. Select Format... to choose the desired output format and format options.

3. Enter a file name prefix to save the image to disk.

– AND/OR –

4. Toggle the “To Printer ...” button on and enter a print command (see Notes below).

5. If desired, automatically convert colors for printing (see notes below).

6. If desired, select a window size option. *Normal* is the current size of the Graphics Window and *Full* is full screen size. If the setting is *User Defined*, you can enter the desired size in the X and Y text fields.

7. Click Print.

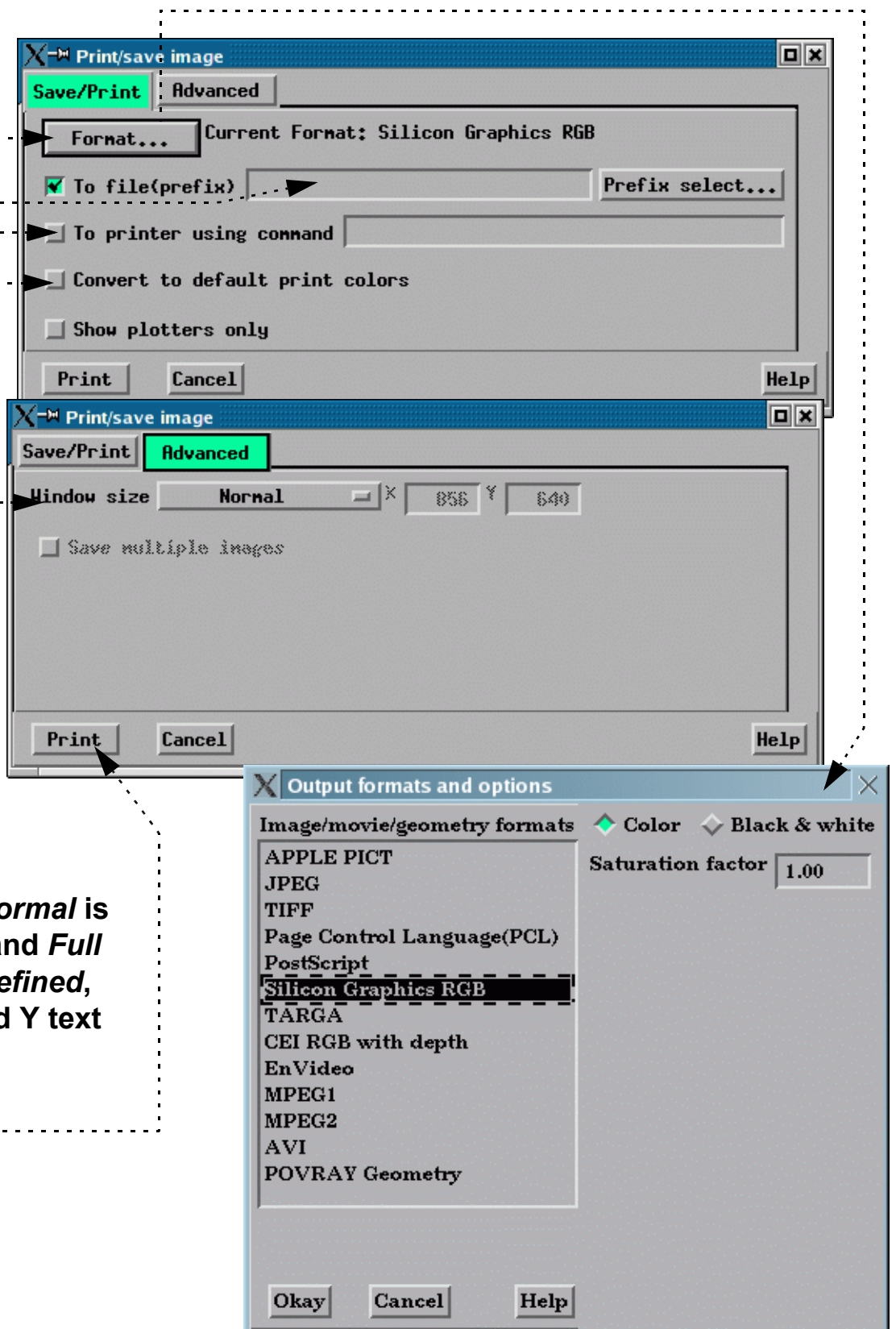

Notes:

1. The file is saved or printed from the EnSight client machine – not the server.
2. The printer command should not include the file name. For example, if you normally print with “lpr -Plaser1 file.ps” then enter “lpr -Plaser1” in the To Printer Using Command field.
3. If you toggle on Convert to default print colors, all viewport background colors are changed to white and any object (part, viewport border, annotation, etc.) currently colored pure white (RGB = 1,1,1) will be changed to black.



Options for Apple PICT Format

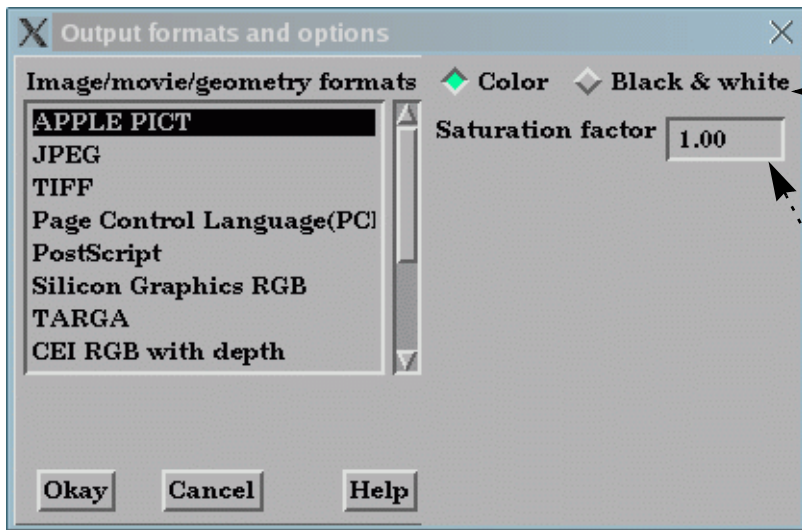

Select either color or black and white output.

Set the saturation factor for color images. Full saturation is 1.0 and no saturation (i.e. white) is 0.0.

Options for JPEG Format

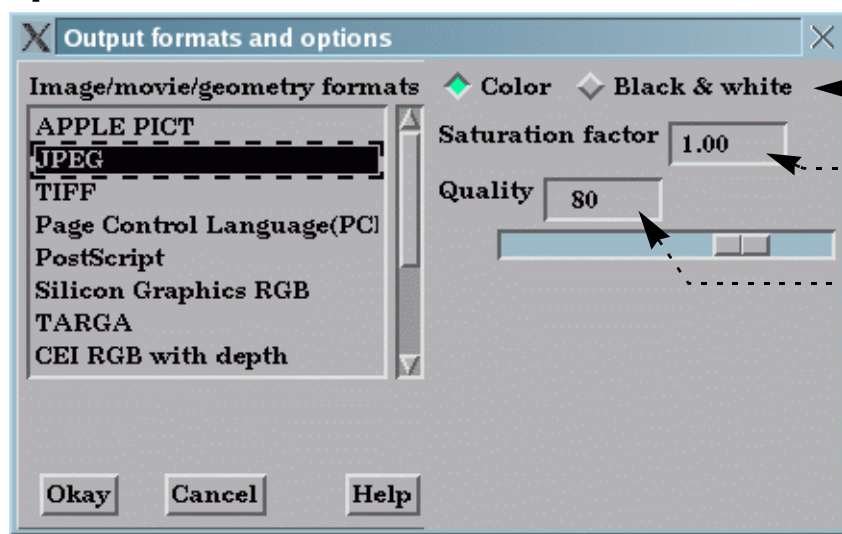

Select either color or black and white output.

Set the saturation factor for color images. Full saturation is 1.0 and no saturation (i.e. white) is 0.0

Set the desired output quality. The value represents a trade-off between fidelity and compression: 100 means maximum fidelity and 0 means maximum compression. You can use the slider to set this value.

Options for TIFF Format

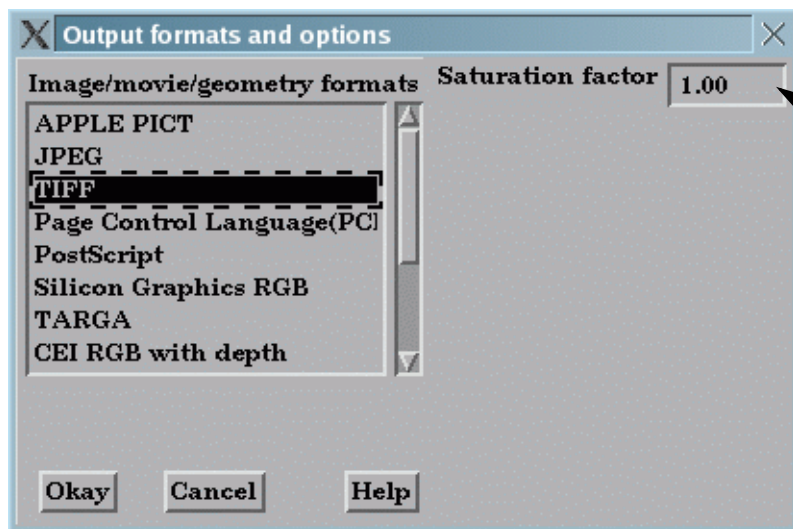

Set the saturation factor for color images. Full saturation is 1.0 and no saturation (i.e. white) is 0.0

Options for PCL Format

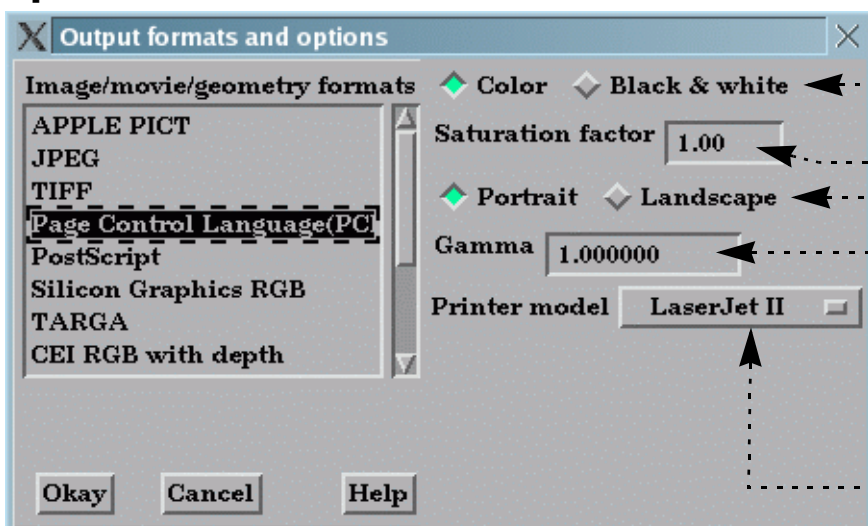

Select either color or black and white output.

Set the saturation factor for color images. Full saturation is 1.0 and no saturation (i.e. white) is 0.0.

Select Portrait or Landscape output orientation.

Set gamma correction factor. Gamma can correct for nonlinearities in monitor brightness.

Select the destination PCL printer model.



Options for PostScript Format

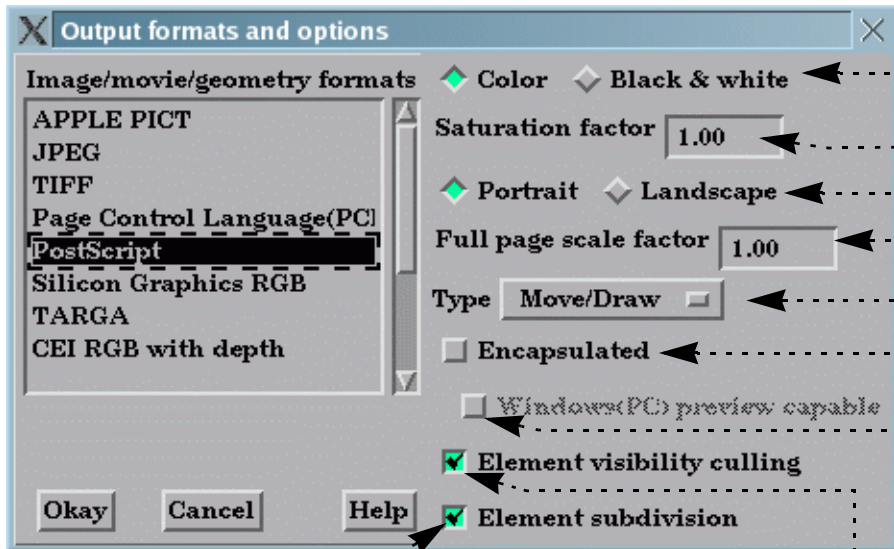

Select either color or black and white output.

Set the saturation factor for color images. Full saturation is 1.0 and no saturation (*i.e.* white) is 0.0.

Select Portrait or Landscape output orientation.

Set the page scale factor.

Select either "Move/Draw" or "Image" PostScript output (see below).

Toggle on for Encapsulated Postscript output.

Toggle on to enable a preview image for EPS files (for import into PC Windows applications ONLY – see [Other Notes](#) below).

Toggle on to remove invisible geometry.

Toggle on to subdivide geometry for smooth color and shading output.

The PostScript format handles primitives either as precise drawing instructions (e.g. move to here, draw a line to here, fill this region) or as sampled images (pixel data). There are advantages and disadvantages to both.

Move/draw output is *resolution-independent* and will reproduce fine lines and text. Since even low resolution printers have 3-4 times the resolution of a typical graphics workstation (in dots/inch), move/draw PostScript typically produces higher quality output. However, for very large models, the output files can become quite large (even with visibility culling on) and subsequent printing can be slow.

In contrast, image or pixel PostScript saves the pixels of the image in the Graphics Window. Such an image is, by definition, fixed resolution. When printed, the pixels will be scaled to fit the page. Since the printer resolution is higher than the screen resolution, each pixel must be printed larger than it appeared on the screen resulting in visible pixels and jagged edges. To improve the quality of image PostScript output, EnSight will print only 3D geometry as pixels – the remaining objects (annotation text, color legends, and plots) will be output as move-draw instructions and will overlay the image.

Options for SGI RGB Format

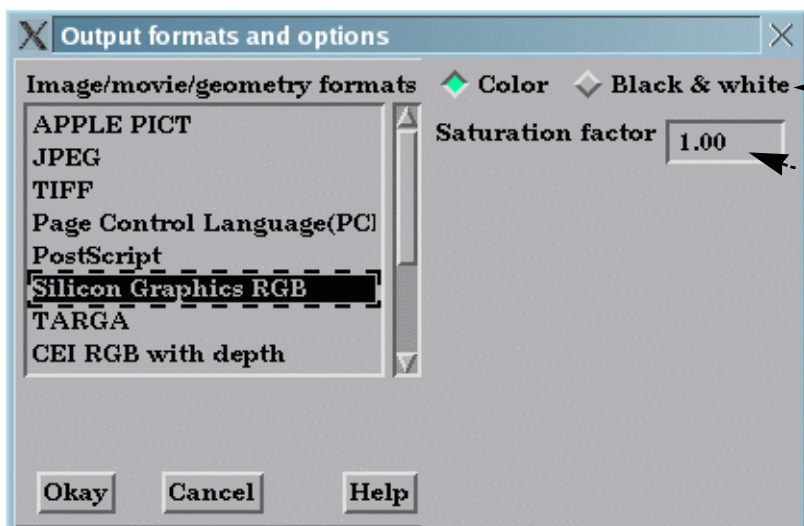

Select either color or black and white output.

Set the saturation factor for color images. Full saturation is 1.0 and no saturation (*i.e.* white) is 0.0.

Options for TARGA Format

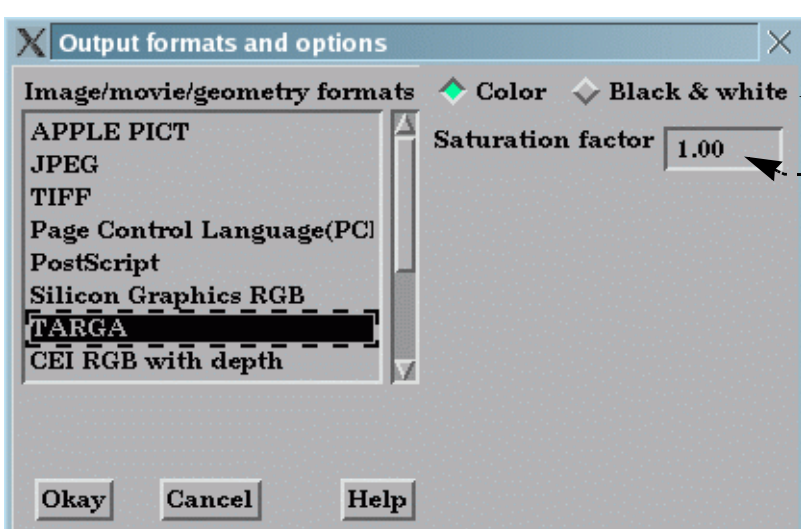

Select either color or black and white output.

Set the saturation factor for color images. Full saturation is 1.0 and no saturation (*i.e.* white) is 0.0



Options for CEI RGB with depth Format

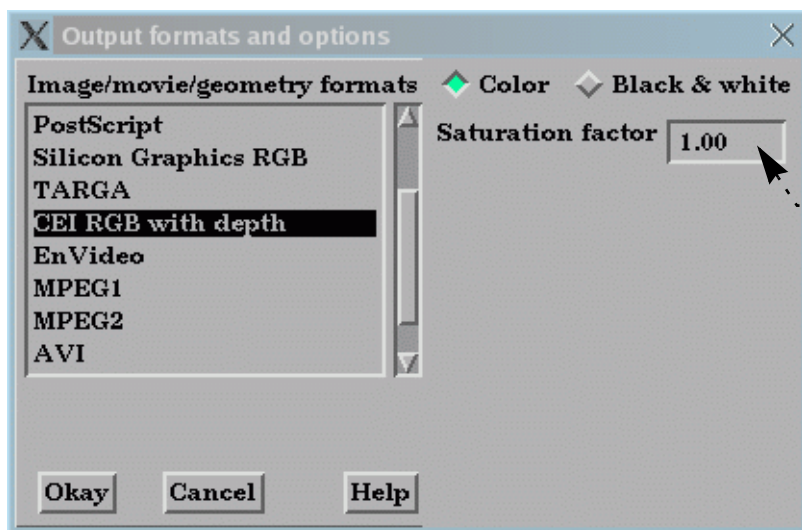

Select either color or black and white output.

Set the saturation factor for color images. Full saturation is 1.0 and no saturation (i.e. white) is 0.0.

Note: This format cannot be viewed or printed. It is used for compositing two or more images according to depth values.

Options for EnVideo Format

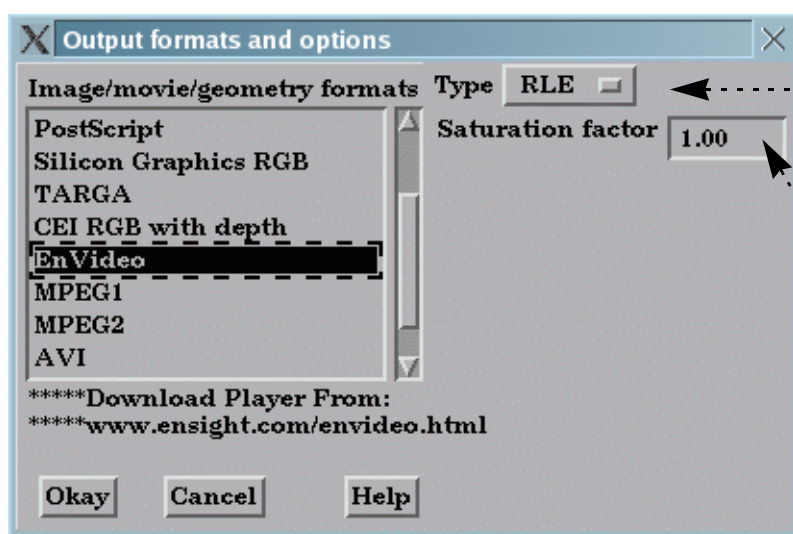

Select Run Length Encoding or JPEG type.

Set the saturation factor for color images. Full saturation is 1.0 and no saturation (i.e. white) is 0.0

Options for MPEG1 or MPEG2 Format

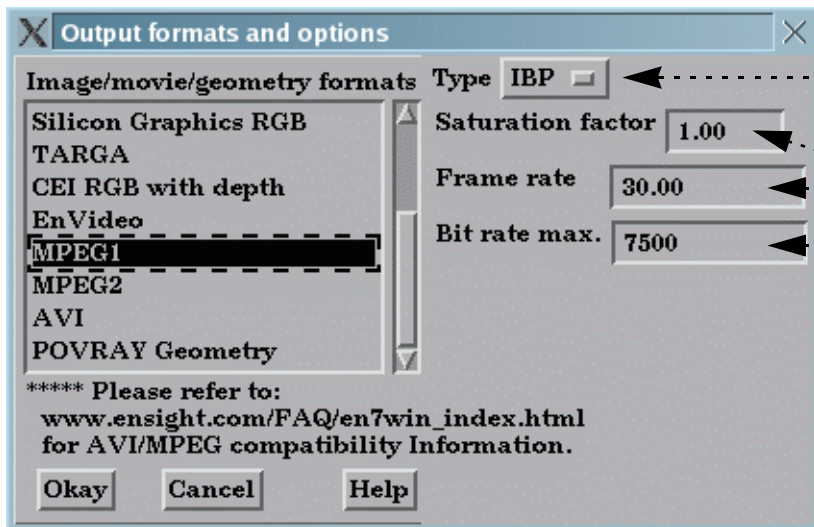

Select IBP or I type.

Set the saturation factor for color images. Full saturation is 1.0 and no saturation (i.e. white) is 0.0

Set the desired Frame rate (frames per sec).

Set the maximum bit rate.

Options for AVI Format

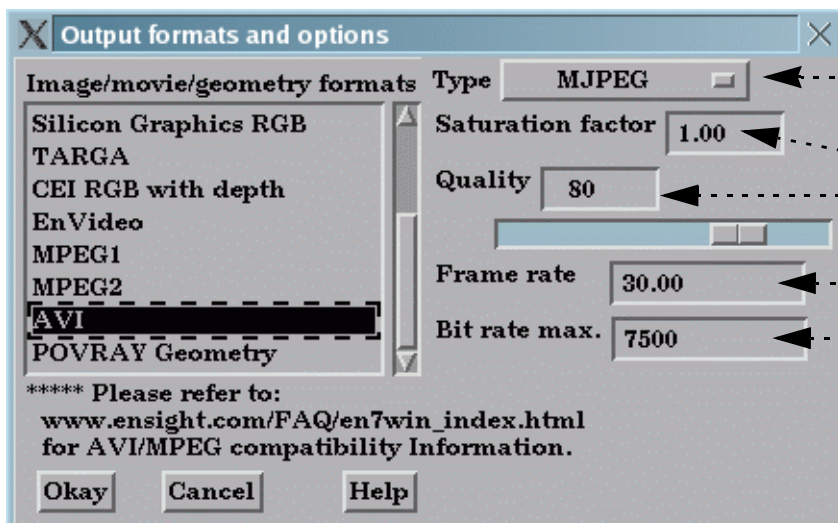

Select MJPEG or Uncompressed type.

Set the saturation factor for color images. Full saturation is 1.0 and no saturation (i.e. white) is 0.0

Set the desired quality. Slider can be used.

Set the desired frame rate (frames per sec).

Set the maximum bit rate.

Note: AVI files are a Microsoft standard format for movies, audio, icons, and other data types.

Uncompressed AVI files can be quite large for even small animations. You can compress these files on your Windows PC using the utility avi_compress.exe found in the "unsupported" directory of the EnSight distribution. This is a



Windows command line based program. To use the utility, copy it and the AVI movie file to a folder on your PC. Then open a 'Command Prompt' window (DOS shell) and change to the folder containing the files. Next, run the command using the following syntax: `avi_compress in.avi out.avi`

where 'in.avi' is the name of the uncompressed movie file and 'out.avi' is the name to use for the compressed movie file. The utility will open a simple dialog box presenting a choice of compression methods available on your PC. For portability reasons, you should probably choose 'Cinepak'. You may choose others but they may not generate portable movies that others can view on their PC.

Options for POV-Ray Geometry Format

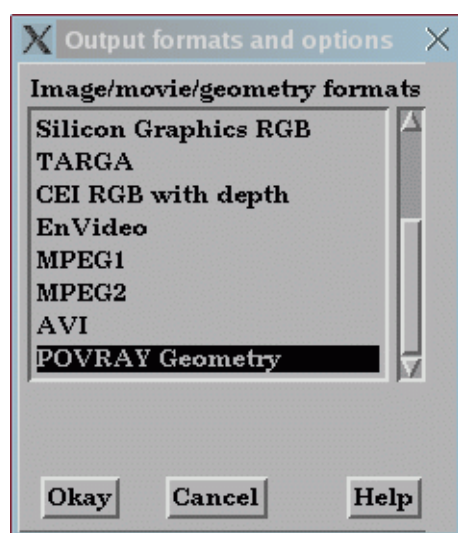

No options to set for this format.

ADVANCED USAGE

Most workstations provide tools to display and manipulate images. Silicon Graphics provides a rich image manipulation environment. See, for example, the manual pages for `imgworks` and `dmconvert`.

There are also some excellent public domain (*i.e.* free) tools for manipulating images. A suite of tools for manipulating and converting images is available from the San Diego Supercomputing Center. You can download pre-compiled binaries for most UNIX workstations from the SDSC FTP server: `ftp.sdsc.edu` in `pub/sdsc/graphics/intools`. ImageMagick is a public domain, X-windows based program for displaying both images and animations (loaded as sequences of images) on a wide variety of platforms. Visit the Web site <http://www.wizards.dupont.com/cristy/ImageMagick.html> for more information.

OTHER NOTES

Almost all desktop publishing, page-layout, or word-processing packages permit importation of Encapsulated PostScript files or PICT files. Macintosh packages recognize files by explicit file typing based on a four letter code (unlike UNIX, which has no intrinsic file-typing). This code is not stored in the file itself, but in an "information file" used by the Finder (the Mac OS) to handle files. EPS files are recognized by the code "EPSF" and PICT images by the code "PICT". There are various methods of setting this code. File transfer utilities such as "fetch" can set the code during the transfer process. The "FileTyper" utility can be used to directly edit the Finder Information File. Unless this file type is set properly, it is likely that applications will refuse to recognize your EPS or PICT files. Send email to fetch@dartmouth.edu for information on fetch.

EPS files typically contain a "preview image" that lets the importing application display a facsimile of the actual graphic for ease in interactive positioning, scaling, or clipping. There are different methods of specifying this image (*e.g.* PICT resources for Macintosh or TIFF files for Windows). Unfortunately, the different methods of specifying the preview image preclude EnSight from providing this capability for import into Macintosh applications. When you import an EPS file, most Macintosh applications will display it as a gray box. You can, however, still resize and position the image and it should print fine. EnSight can, however, attach a preview image that can be used by Windows applications. Enable the "Windows (PC) Preview Capable" toggle in the Image Format Options dialog. The suffix ".EPS" should be used for the resulting files.

Do not attempt to send a PostScript file containing a preview image to a printer!

SEE ALSO

User Manual: [Saving and Printing Graphic Images](#)



INTRODUCTION

EnSight can has three internal writers that allow saving geometric data and variable values in Brick of Values, Case (EnSight Gold) or VRML. EnSight also allows the user to create their own writer as a dynamic shared library that is loaded at runtime and listed in the addition to the internal writer formats.

BASIC OPERATION

Saving Parts in EnSight Gold or VRML Formats

1. Select File >

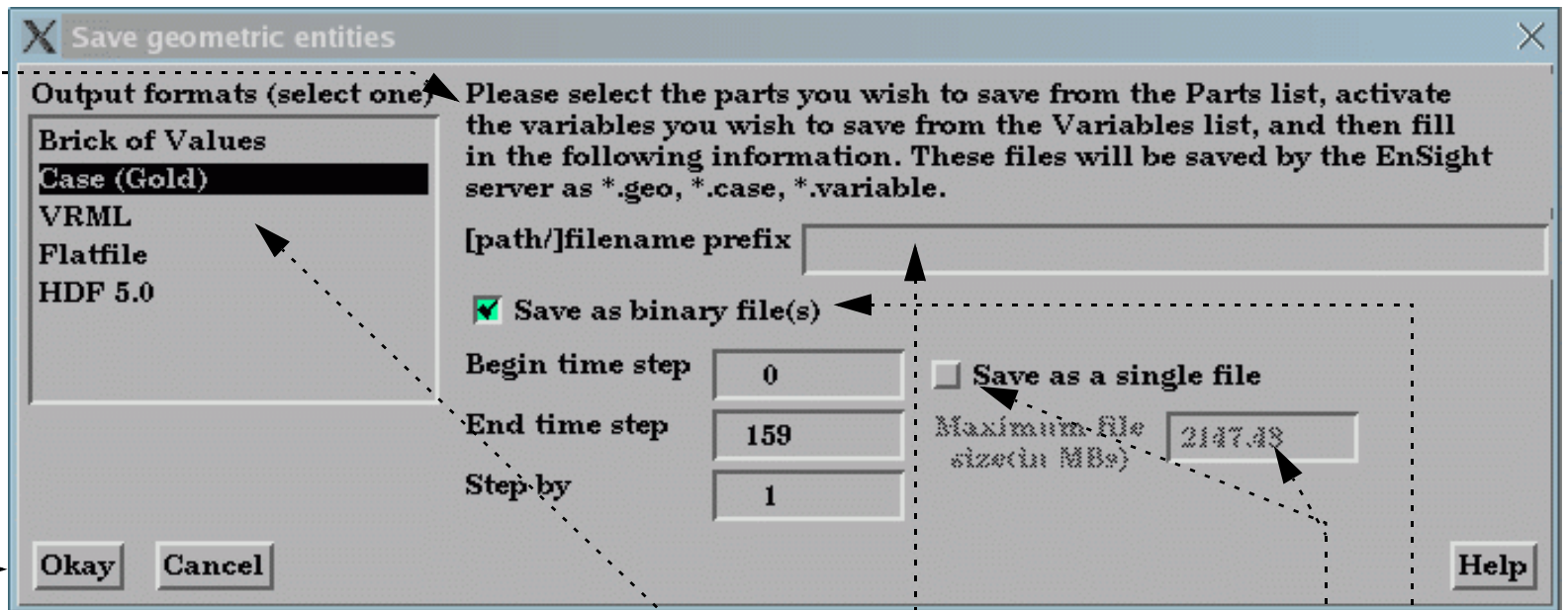

2. Be sure the desired output format is selected.

3. Follow the instructions given.

4. Enter a file root name.

5. If the dataset is transient, specify the beginning, ending, and step values.

For EnSight Gold only:

6. Toggle to save as binary files or not.

7. If the dataset is transient you can choose to save the multiple timesteps in one file (one file per variable). If you choose this option, you can also specify the maximum file size.

8. Click Okay.

Both internal and user-defined writers have access only to the geometry of selected parts and each of their active variables. Only parts located on the server can be saved. This includes all original model parts, and the following created parts: 2D-clips, Elevated Surfaces, Developed Surfaces, and Isosurfaces. The VRML internal writer saves all the visible parts on the server (thus, particle traces, vector arrows, contours, etc. will not be saved) in their current visible state except for Parts which have limit fringes set to transparent. The VRML file will be saved on the client.

Output in the EnSight formats is intended to provide a method to save both model and created parts (with active variables) for subsequent reuse with EnSight. VRML output is intended for export to other systems.

Most World Wide Web browsers come with either built-in or plug-in support for VRML file viewing. Since VRML is a subset of the Inventor format, you can also import it into programs accepting Inventor files. You may, however, have to modify the first line of the file (with any text editor) to read:

```
#Inventor V2.0 ascii
```

This may work when importing VRML into Showcase from Silicon Graphics (a presentation layout tool). Once imported, the 3D model can still be manipulated – even during a presentation.

There are some important differences in how EnSight saves parts according to format chosen.

	Case(EnSight Gold)	VRML
Which parts are saved?	All parts currently selected in the Main Parts List (except those indicated below)	All visible parts
Saved from where?	EnSight server	EnSight client
Which parts <i>cannot</i> be saved?	Any client-based part: contours, vector arrows, particle traces, profiles.	





Saving Parts in Brick of Values Format

1. Select File > Save > Geometric Entities...

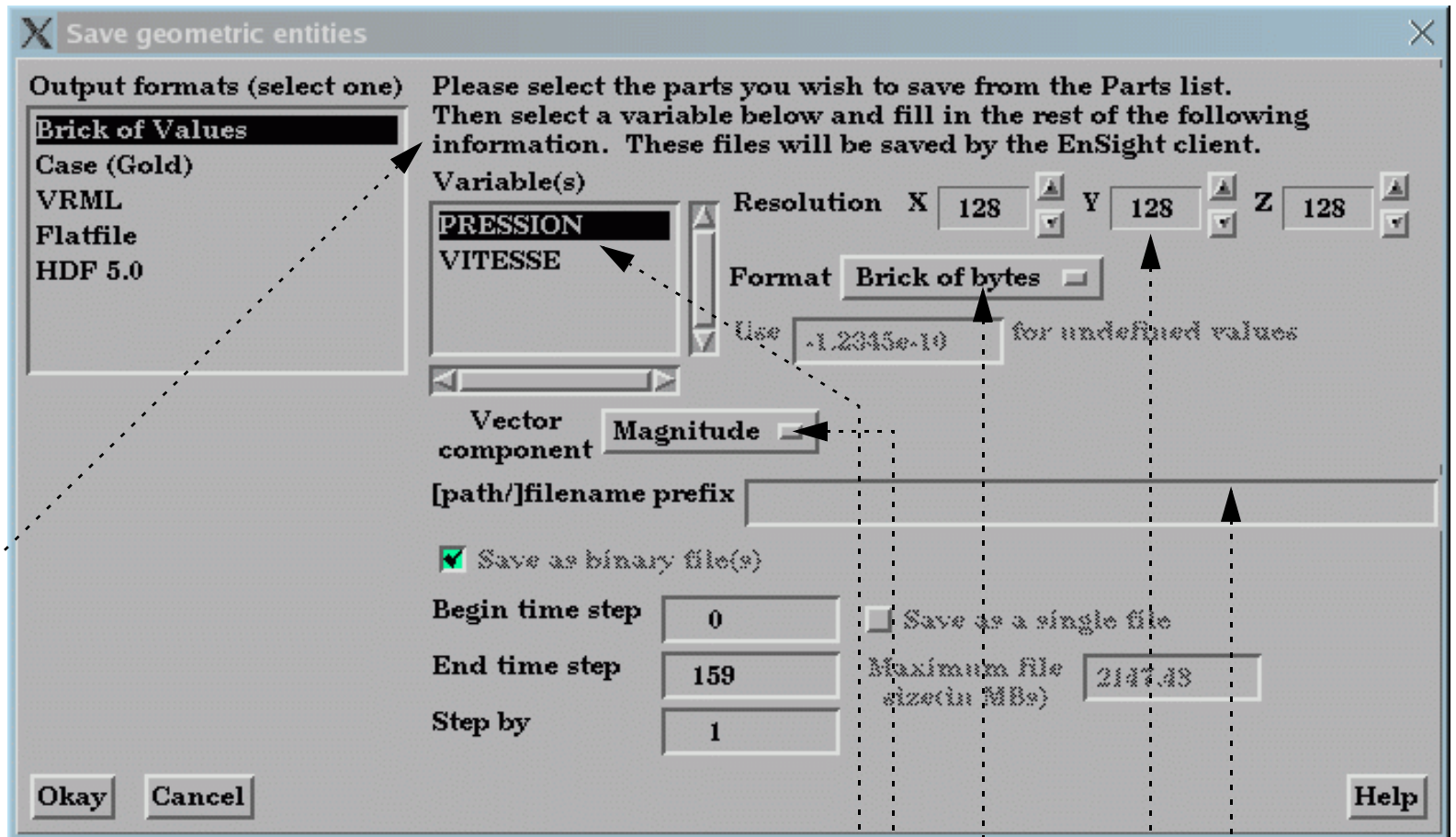

2. Be sure Brick of Values is selected as the Format type.
3. Follow the instructions given.
4. Select the desired variable.
5. If the variable is a vector, select the component desired.
6. Select the sampling resolution.
7. Select the sampling format, Brick of Bytes or Brick of Floats.
8. Enter a file root name.
9. Click Okay.

Brick of Bytes and Brick of Floats is intended to give you an interface mechanism to volume rendering codes.

When you click the Okay button the selected parts are discretized to the resolution indicated using the box tool as the bounds and orientation (x/y/z resolution refers to the x/y/z directions for the box tool).

For Brick of Bytes (BoB) format a value of 0 is reserved for undefined (i.e., the discretized point found no variable information). The value of 1 is tied to all variable values less than or equal to the minimum palette value tied to the variable chosen while 255 is tied to all values greater to or equal to the maximum palette value.

For Brick of Floats (BoF) format undefined values are assigned the undefined value indicated in dialog.

Both BoB and BoF files are written out without any metadata - only the values for the discretized points is written. The order of the data is according to the following pseudo code:

```

num_values = 0
for(z=0; z<z_resolution; ++z) {
  for(y=0; y<y_resolution; ++y) {
    for(x=0; x<x_resolution; ++x) {
      value_array[num_values] = value_at_this_location
    }
  }
}
write(file_name,value_array)
    
```



Saving Parts in User Defined Writer Formats (Flatfile, HDF 5.0, ...)

1. Select File > Save > Geometric Entities...

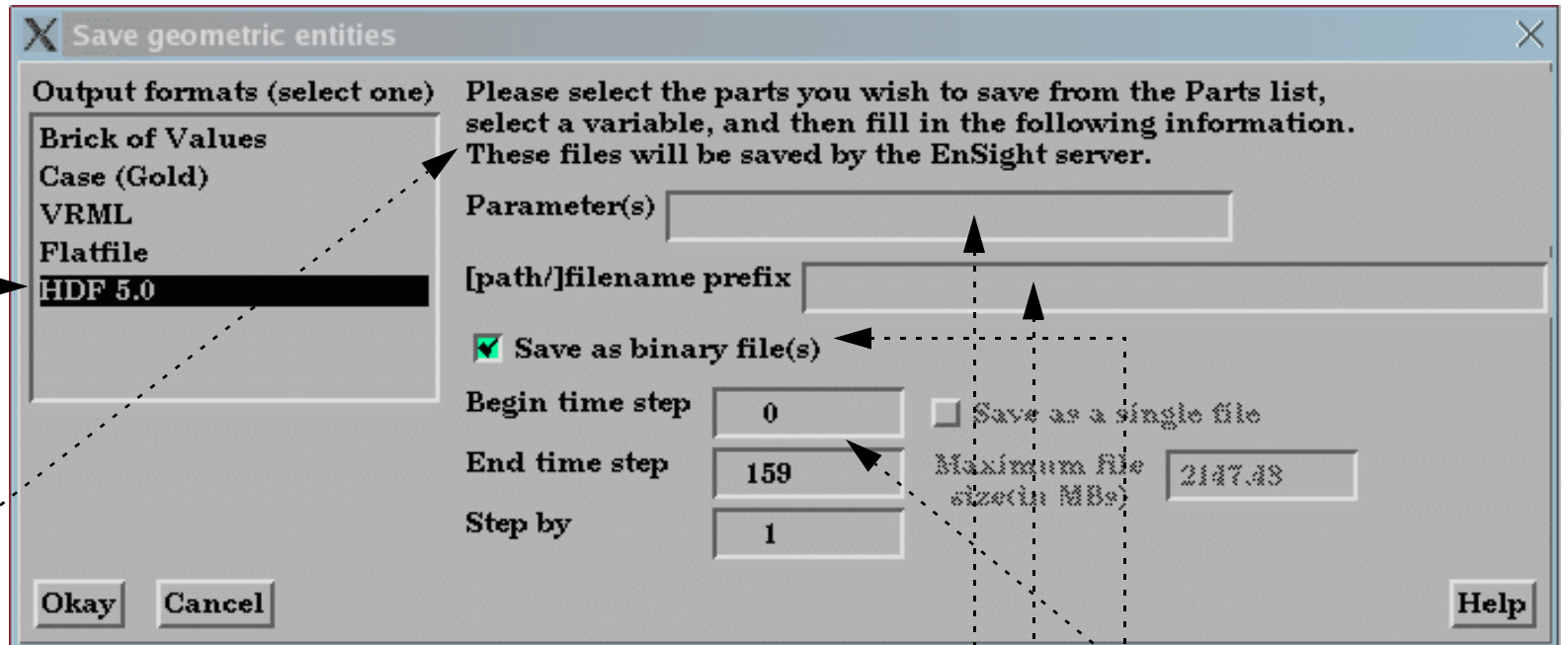

2. Select the desired user defined writer format.

3. Follow the instructions given.

4. If the writer accepts parameters, enter any desired ones in the Parameter(s) field.

5. Enter a file root name.

6. Save as binary or Ascii file, based on this toggle.

7. If the dataset is transient, specify the Time Step info.

(Note that some writers produce static data, and thus may only use the Begin Time Step info)

8. Click Okay.

The user-defined writers can call the routines of an EnSight API to retrieve, for example, nodal coordinates, node ids, element ids of parts selected in the Parts window, to be passed by value to be used, manipulated and/or written out in any format desired. The User-defined writer dialog includes a Parameter field that allows the passing of text into the writer from the GUI. This text could contain extra options which the writer understands.

Several example writers (including source code header files, Makefile and the corresponding shared library) are included to demonstrate this capability.

The Case (Gold) Lite reader is included to demonstrate how to exercise most of the API and output a subset of the Case (Gold) format. Complex numbers and custom Gold format are not supported with this writer. The Case (Gold) writer ignores the Parameter field. While the writer is not compiled, the source code of this writer, the required header files, and the Makefile are included.

The Flatfile user-defined writer is designed to demonstrate the output of selected part nodal data (coordinates & IDs) as well as active variable values (scalar and/or vector only) in a comma delimited format easily imported into other applications. If any of the keywords 'ANSYS' or 'force' or 'body' is entered into the Parameter field, then Flatfile will output an ANSYS body force file.

The HDF 5.0 writer is designed to write out selected parts and their corresponding active variables using the HDF 5.0 API which is compatible with the EnSight HDF user-defined reader. The HDF writer ignores the Parameter field.

The STL user-defined writer is designed to write out the border geometry in the form of triangular 2D elements of the selected part(s) at the beginning timestep. The end time and the step time are ignored. The STL format does not support multiple parts in a single binary file, but does support multiple parts in a single ASCII file. Therefore, if multiple parts are selected and ascii is checked, the STL writer outputs an ascii file with the border of each of the parts. If multiple parts are selected and binary is checked, the STL writer outputs a binary file containing a single border of the multiple parts. The STL writer only saves the beginning timestep and ignores the End Timestep and Step By fields. The STL writer ignores the Parameter field.



There are some important differences in how EnSight saves parts according to format chosen.

	User Defined Writers (UDW)
Which parts are available to the UDW?	All parts currently selected in the Main Parts List (except those indicated below)
Where are the available parts located?	EnSight server
Which parts are unavailable to the UDW?	Any client-based part: contours, vector arrows, particle traces, profiles

More user-defined writers may be distributed with EnSight in the future.

SEE ALSO

User Manual: [Saving Geometric Entities](#)

Readme file is \$CEI_HOME/ensight80/src/writers/README

INTRODUCTION

EnSight context files can be used to duplicate the current EnSight state with the same or a different, but similar, dataset. The context file works best if the dataset it is being applied to contains the same variable names and parts, but can also be used when this is not the case.

BASIC OPERATION

An EnSight context consists of a set of files: the context file itself as well as associated palette, view, and keyframe animation files. The names of the associated files will be that of the context file with a standard extension.

Saving a Context

1. Select **File > Save > Context...** to open the **Save Current Context** dialog.

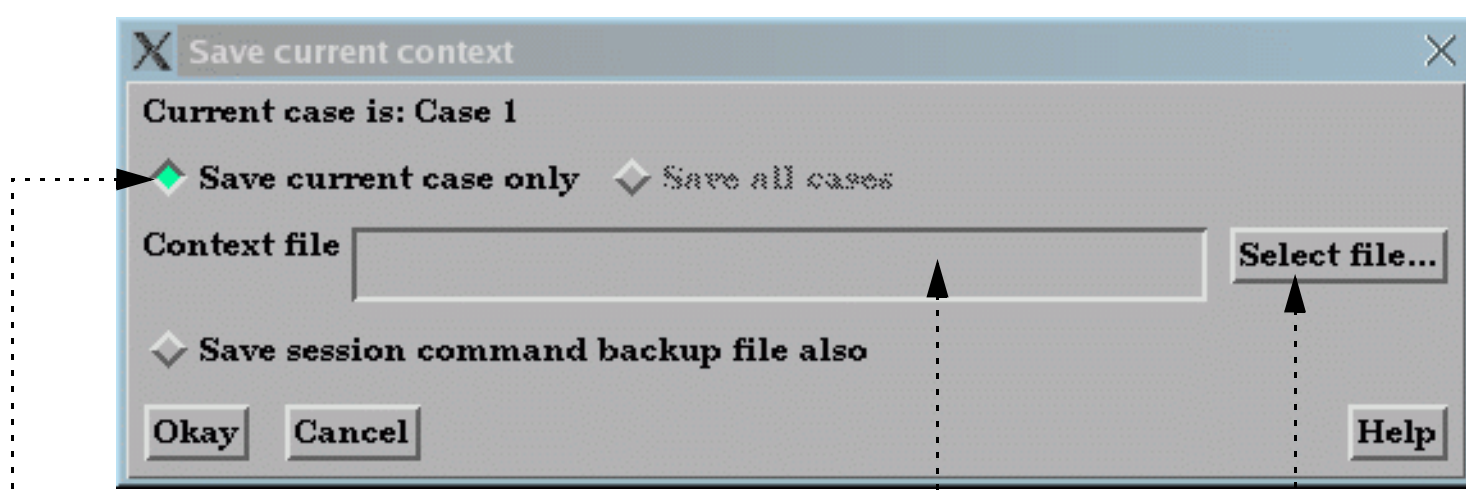

2. Toggle **Save Current Case Only** or **Save All Cases**.
3. Enter a name for the **Context File**.
You can set the directory for the **Context File** by clicking the **Select File...** button to open a standard **File Selection** dialog.
4. Click **Okay**.

Restoring a Context

Three options:

- 1) Start EnSight and restore a context as described below. This will recreate the parts of the original dataset and restore them to their saved condition.
- 2) Start EnSight, read a new dataset, cancel the part loader without creating parts, and restore a context as described below. This will create the parts of the new dataset (mapping as directed) and restore the context of the original dataset.
- 3) Start EnSight, read a new dataset, create the desired parts, and restore a context as described below. This will do the mapping (as directed) of parts and restore the context of the original dataset.

1. Select **File > Restore > Context...**

2. Select the case to restore the context to.

Note: If the context file contains information for multiple cases, ignores the selection

3. Enter or select the desired context file

4. Click **Okay**.

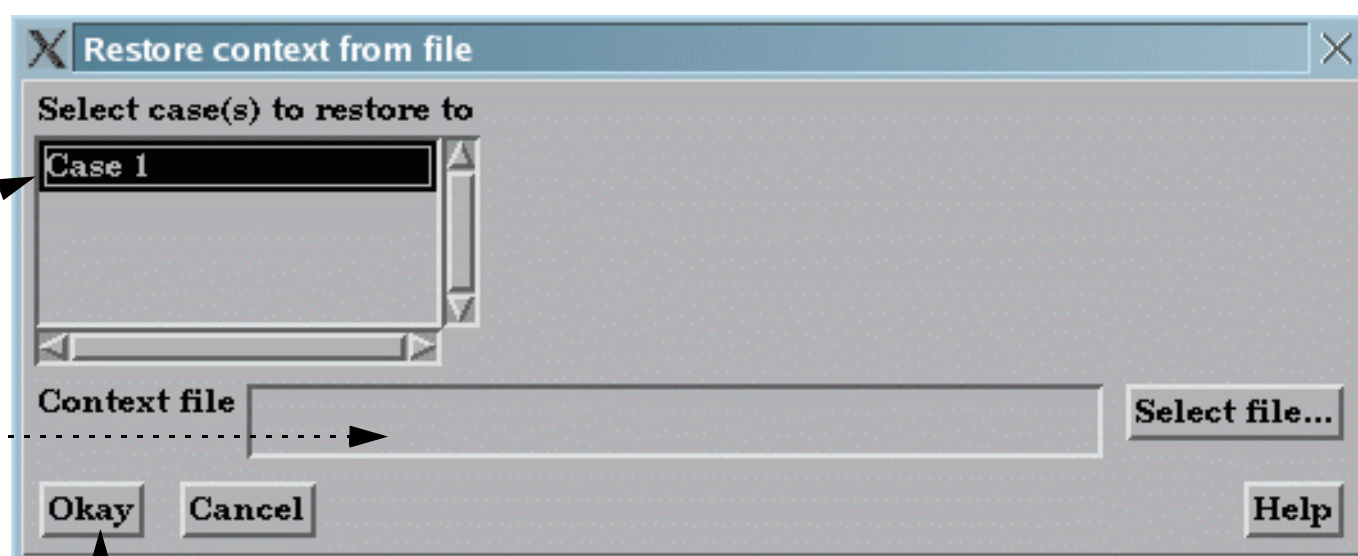



OTHER NOTES

The same part names (and variable names) do not have to exist in the new case. If this situation arises, a pop-up dialog will appear where you will be asked to match the part names (or variable names) from the context file with the parts (or variables) from the new case. This dialog is not available in batch mode. Therefore, you can't use a context file that needs matching in batch mode.

When restoring context files with multiple cases, the needed cases will be started, if needed, according to the connection scheme of the current run of EnSight.

Flipbook animations are not restored using the context file because it is unknown at the time the context file is created what state existed when the flipbook was saved.

If data is not read before restoring the context file, the data that was used when the context file was saved will be loaded.

Context files use EnSight's command language and other state files (such as palette, view, and keyframe animation) to recreate the parts, variables, and view state.

SEE ALSO

User Manual: [File Menu Functions](#)

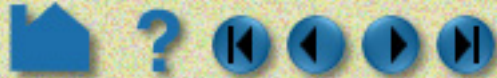

INTRODUCTION

Scenario files are used by CEI's EnLiten product which is capable of viewing all geometry (such as parts, annotation, plots, etc.) that EnSight can display, including flipbook, keyframe, and particle trace animations.

A "scenario" defines all visible entities you wish to view with EnLiten and includes any saved views and notes that you want to make available to the EnLiten user.

BASIC OPERATION

1. Create the display you want to share with the EnLiten user.
2. Select File > Save > Scenario... to open the Save Scenario dialog.
3. Select File to save a scenario file only, or Project to save the scenario, jpg image file, and EnSight context file.
4. Choose the EnLiten1 or CSF format.
5. Enter a name for the Scenario file/ directory. You can set the root directory for the Scenario by clicking the Select... button to open a standard File Selection dialog.
6. If you currently have flipbook, keyframe, and/or particle trace animations, indicate if you want these saved to the scenario file.
7. Save the scenario.

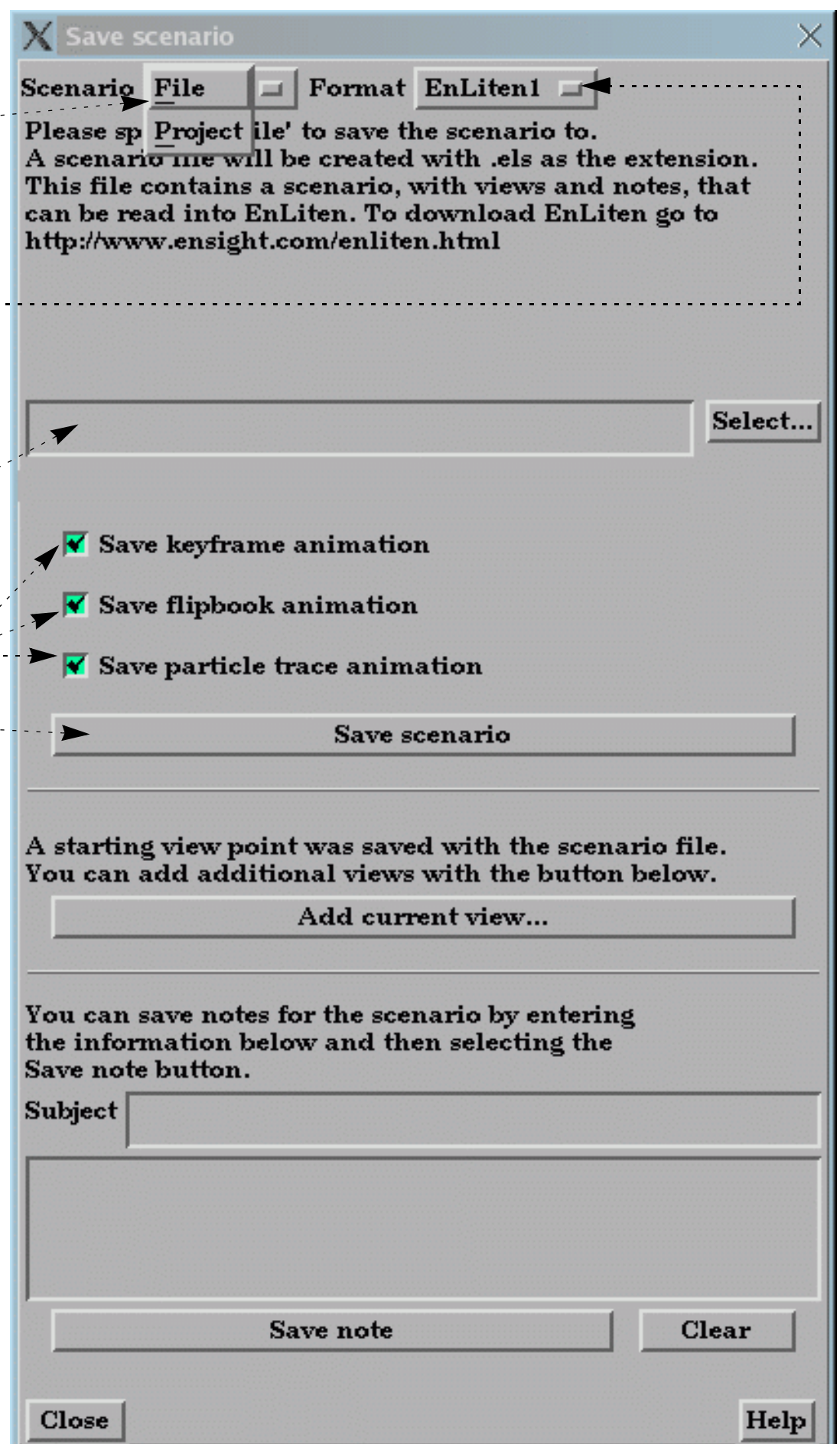

ADVANCED USAGE

After the scenario has been saved you may save additional views by setting the desired view in EnSight, then selecting the "Add Current View...". You will be asked to name the view in a resulting pop-up dialog.

After the scenario has been saved you may write notes regarding the scenario by entering a Subject line and typing in the notes input area. When satisfied, select the "Save Note" button.



OTHER NOTES

EnLiten is a geometry viewer only. As such it is not capable of creating or modifying any new/existing information such as variables or parts, or of changing timesteps.

Since EnLiten is only a geometry viewer, only keyframe transformation information is stored when saving a scenario file, i.e., no transient data keyframing is possible (consider loading a flipbook instead).

SEE ALSO

User Manual: [File Menu Functions](#)





Output for Povray

INTRODUCTION

EnSight can output a file which can be read into POV-Ray (Persistence of Vision Ray Tracing). This allows EnSight images to be able to have shadows and reflections which ray tracing can provide. POV-Ray must be downloaded and installed separately from EnSight (www.povray.org).

Note: This option requires that you have an EnSight Gold license

BASIC OPERATION

The process is:

1. Run ensight and produce the desired image in the graphics window.
2. Go to File > Print/Save Image and set the Format to POV-Ray Geometry and save.

This will produce the following files (samples of which are given in the Other Data section below):

`filename.pov`
`filename.inc`
`ensight_to_pov_globals.inc`

3. Edit `ensight_to_pov_globals.inc` as desired to control global information. You may also edit the `filename.inc` file which contains information for each part.

4. Run POV-Ray

```
povray width=800 height=600 filename.pov
```

This will produce the file:

`filename.png`

5. Run Envideo8 using this file:

```
envideo8 filename.png
```

EnSight Images - No POV-Ray

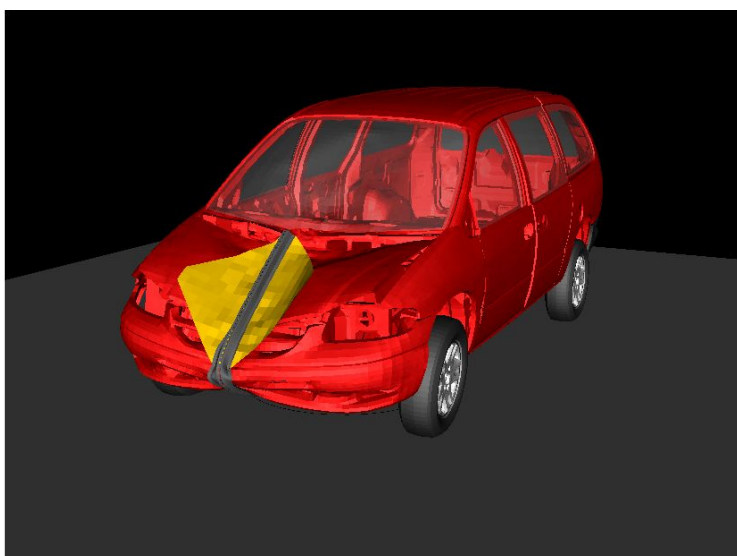
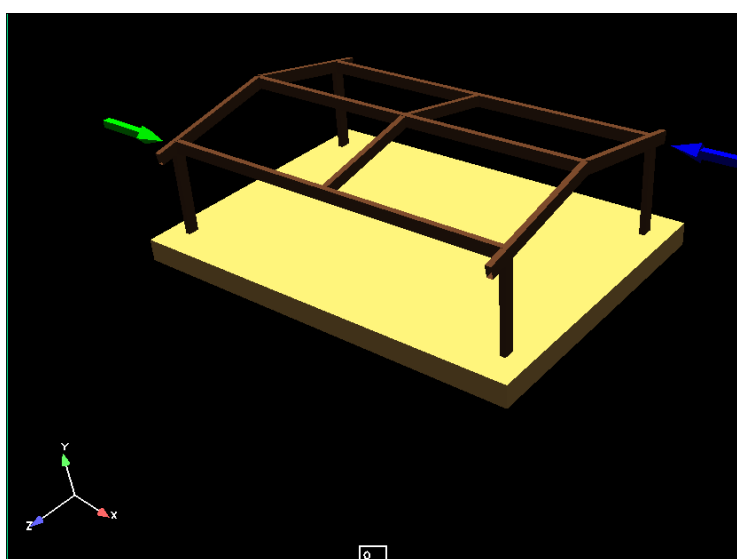

EnSight Images which have been run through POV-Ray

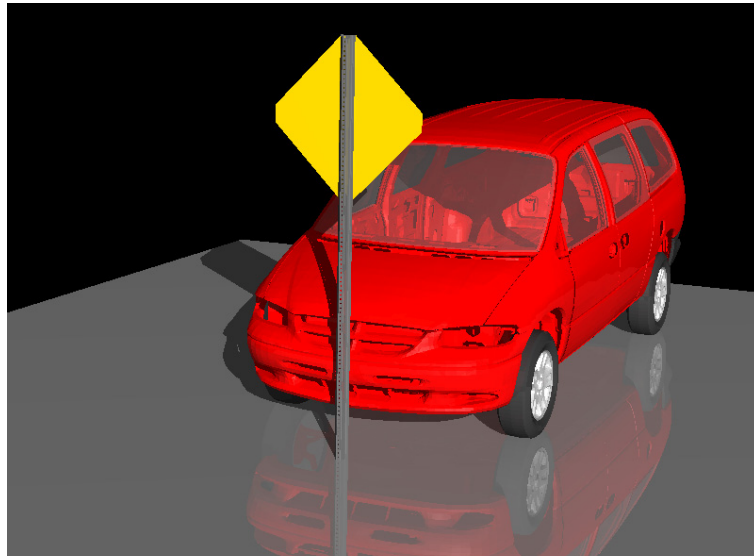
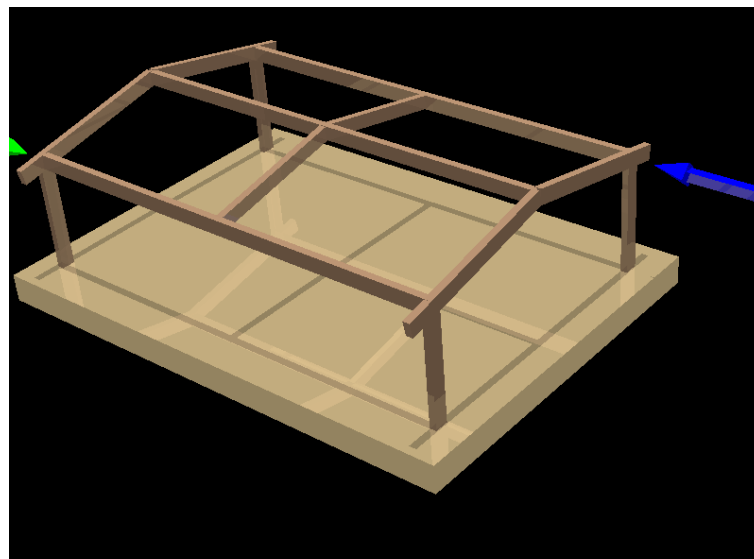



OTHER DATA

ensight_to_pov_globals.inc

This is the editable text file to be used to customize the camera and lightsource information, and the part by part color and material properties (ambient, diffuse, specular, roughness, and reflectivity). This file will be included into filename.inc and parameters in this file will supersede the default values in filename.inc.

```

////////////////////sample_ensight_to_pov_globals.inc////////////////////
//
// This file is useful in controlling multiple file outputs
// (i.e., output from the keyframe animator). Uncomment/edit items
// and they will be used instead of the settings in the .inc file
//
// Uncomment this next line if you uncomment anything
//#declare display_warning = 1;
//
//#declare camera_location = <-0 0 8366.19>;
//#declare camera_look_at = <-0 0 -16.7612>;
//#declare camera_angle = 28.000000;
//
//#declare light_location = <-15241.7 15241.7 76191.9>;
//#declare light_color = rgb <1 1 1>;
//
// This will set reflective value for all parts
//#declare reflect_value = .1;
//
// If you want to set the color for a part you would do this
// (useful if you have many .pov files since all the .inc files
// include this file)
//
//#declare Part_1_material = texture {
// pigment { color rgbt <1. 0. 0. 0.> }
// finish {
// ambient 0.3
// diffuse 1.0
// specular 0.0
// roughness 0.2
//#ifdef (reflect_value)
// reflection reflect_value
//#else
// reflection .1
//#end
// }
//}
#declare Part_495_material = texture {
pigment { color rgbt <0.600000 0.600000 0.600000 0.000000> }
finish {
ambient 0.300000
diffuse 1.0
specular 0.000000
roughness 0.027778
#ifdef (reflect_value)
reflection .2
#else
reflection .2
#endif
}
}

```





filename.inc

This text file has a statement that includes `ensight_to_pov_globals.inc` and then has the default global camera and lightsource information as well as default Part by Part values of color and material properties.

```

////////////////////////////////////sample filename.inc //////////////////////////////////////
#include "ensight_to_pov_globals.inc"

#ifdef (display_warning)
#debug "\n*****\n"
#debug " \n"
#debug " Have applied settings for ensight_to_pov_globals.inc!! \n"
#debug " \n"
#debug "\n*****\n"
#end

camera {
#ifdef (camera_location)
    location camera_location
#else
    location <-0 0 8837.74>
#end
#ifdef (camera_look_at)
    look_at camera_look_at
#else
    look_at <-0 0 0>
#end
#ifdef (camera_angle)
    angle camera_angle
#else
    angle 28.000000
#end
}

light_source {
#ifdef (light_location)
    light_location
#else
    <-14334 10667.6 78331>
#end
#ifdef (light_color)
    color light_color
#else
    color red 1 green 1 blue 1
#end }

#ifdef (Part_1_material)
#declare Part_1_material = texture {
    pigment { color rgbt <1.000000 0.000000 0.000000 0.000000> }
    finish {
        ambient 0.300000
        diffuse 1.0
        specular 0.300000
        roughness 0.027778
    }
#ifdef (reflect_value)
    reflection reflect_value
#else
    reflection .1
#end
}
#end

#ifdef (Part_2_material)
#declare Part_2_material = texture {
    pigment { color rgbt <1.000000 0.000000 0.000000 0.000000> }
    finish {
        ambient 0.300000
        diffuse 1.0
        specular 0.300000
        roughness 0.027778
    }
#ifdef (reflect_value)
    reflection reflect_value

```





```
#else
    reflection .1
#end
}
}
#end
```

filename.pov

A text file that has a statement including filename.inc to define camera, lightsource and Part properties. The remainder of the file contains coordinates and connectivity defining the surface of the Ensign parts as Povray surface triangular elements. ***This file shouldn't be edited by the user.***

```
////////////////////////////////sample filename.pov //////////////////////////////////
#version 3.5;

#include "carapov00.inc"
#declare Part_1=
mesh2 {
    vertex_vectors {
        297
        <-243.353, -1002.62, 3.4535>,
        <723.621, -213.728, -129.889>,
        <731.815, -205.655, -144.313>,
        <740.01, -197.583, -158.737>,
        <748.204, -189.51, -173.161>,
        <722.484, -203.276, -123.341>,
        <730.534, -195.257, -137.655>,
        <738.584, -187.239, -151.97>,
        ....
    }
    face_indices {
        490,
        <1,2,6>,
        <1,6,5>,
        <2,3,7>,
        <2,7,6>,
        <3,4,8>,
        ...
    }
}
#declare Part_2=
mesh2 {
    vertex_vectors {
        2001
        <-243.353, -1002.62, 3.4535>,
        <788.215, -136.402, -241.148>,
        <781.139, -143.803, -228.672>,
        ...
    }
    face_indices {
        490,
        <1,2,6>,
        <1,6,5>,
        <2,3,7>,
        <2,7,6>,
        <3,4,8>,
        ...
    }
}

object {
    Part_1
    texture {Part_1_material}
    scale <-1 1 1>
}
...

object {
    Part_495
    texture {Part_495_material}
    scale <-1 1 1>
}
```





Manipulate Viewing Parameters
Rotate, Zoom, Translate, Scale

INTRODUCTION

EnSight provides global transformations (rotation, translation, and zooming) to permit user manipulation of objects in the Graphics Window. The transformations can either be performed interactively with the mouse, or precisely by entering explicit values. The mouse buttons can be user-programmed to perform different transformations.

BASIC OPERATION

The Transformation Control Area controls the operation of the left mouse button (by default) in the Graphics Window. The icon of the current action will be highlighted (e.g. Rotate is current below):

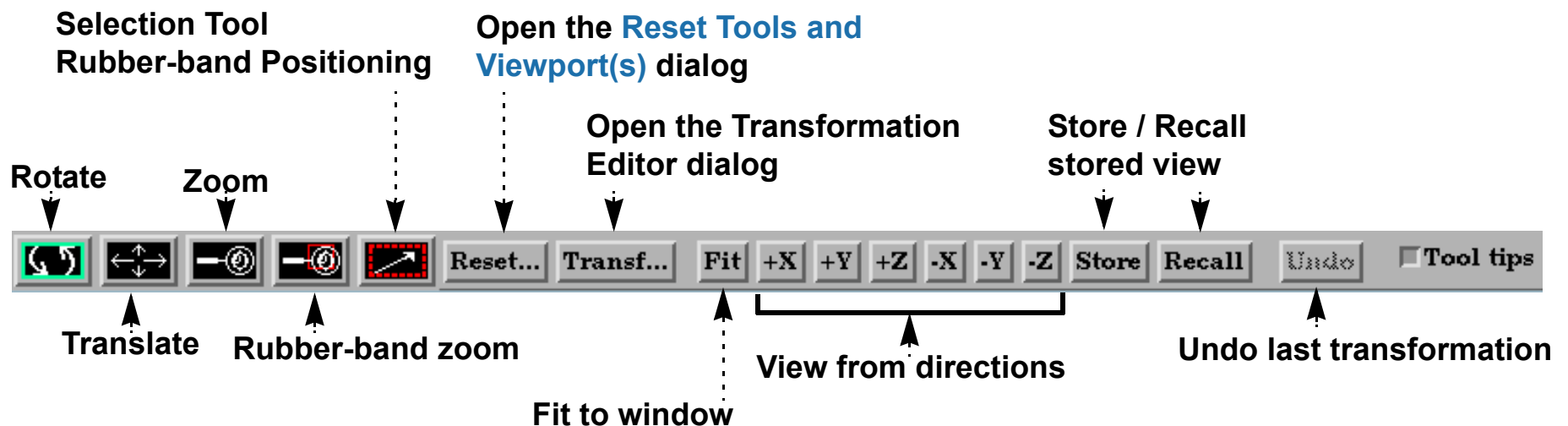

Select Part [or View] mode in the Mode Selection area.

To rotate:

1. Click the rotate icon.
2. Move the mouse pointer into the Graphics Window.
3. Click and hold the left mouse button and:
 - move the mouse left and right to rotate about the screen Y (vertical) axis, or
 - move the mouse up and down to rotate about the screen X (horizontal) axis, or
 - hold down the Control key and move the mouse left and right to rotate about the screen Z axis.
4. Press the F1, F2 or F3 keys for 45 degree rotation about the X, Y, or Z axis, respectively. Hold the Control key down for -45 degree rotation. (Note: cursor must be in the EnSight window for F keys to work)
5. Press +X to view the scene from the positive X axis (looking toward the origin). The +Y, +Z, -X, -Y, -Z buttons are similar. Press the "Last" button to get the scene back to the view that existed before any of the +/-XYZ keys were pressed.

To translate:

1. Click the translate icon (or use the middle mouse button in steps 2 and 3 (default)).
2. Move the mouse pointer into the Graphics Window.
3. Click and hold the left mouse button and:
 - move the mouse left and right to translate in the screen X (horizontal) direction, or
 - move the mouse up and down to translate about the screen Y (vertical) direction, or
 - hold down the Control key and move the mouse left and right to translate in the screen Z direction.

To zoom:

1. Click the zoom icon (or use the middle mouse button in steps 2 through 5 (default)).
2. Move the mouse pointer into the Graphics Window.
3. Click and hold the left mouse button.
4. Drag down to zoom in or drag up to zoom out.
5. Hold down the Control key and move the mouse to pan.

To rubber-band zoom:

1. Click the rubber-band zoom icon.
2. Move the mouse pointer into the Graphics Window and position it at one corner of the desired viewing region.
3. Click and hold the left mouse button.
4. Drag to include the desired viewing region. An outline of the region will appear as you drag.

To rubber-band zoom using the selection tool:

1. Click the Selection Tool Rubber-band Positioning icon.
2. Move the mouse pointer into the Graphics Window and position it approximately at one corner of the desired viewing region.
3. Click and hold the left mouse button.
4. Drag to include the desired viewing region. An outline of the region will appear as you drag.
5. Manipulate the tool as desired, by clicking at the center and dragging to a new position or clicking on any corner and resizing. (Note that the aspect ratio will be preserved as indicated by the dotted lines within the tool.)
6. Click the zoom (magnifying glass) indicator at the top left of the tool.

Note that zooming actually changes the location of EnSight's virtual "camera" or "look-from" point. Zooming in moves the camera closer to the object; zooming out moves it farther away. The [look-from/look-at points](#) can also be edited explicitly.

If you have multiple [viewports](#) visible, each one can be manipulated independently. To transform in a different viewport, place the mouse pointer within the bounds of that viewport before you click the left mouse button.

You can reset transformation parameters (as well as tool and frame transforms) by clicking the Reset... See [How To Reset Tools and Viewports](#) for more information.

The Fit button is useful in causing the currently visible parts to be centered and zoomed to fit within the viewport.

ADVANCED USAGE

All EnSight transformations can be controlled precisely by specifying explicit transforms in the Transformations Editor dialog. To open the dialog, click the Transf Edit... icon on the desktop. The slider performs the requested transformation (based on the selected transformation action) in the selected viewport(s).

Select the desired transformation action.

Slider to specify transform.

Set (by clicking within the desired region) the viewport that the transform applies to.

To interactively perform transformations on multiple viewports, select viewports then toggle on.

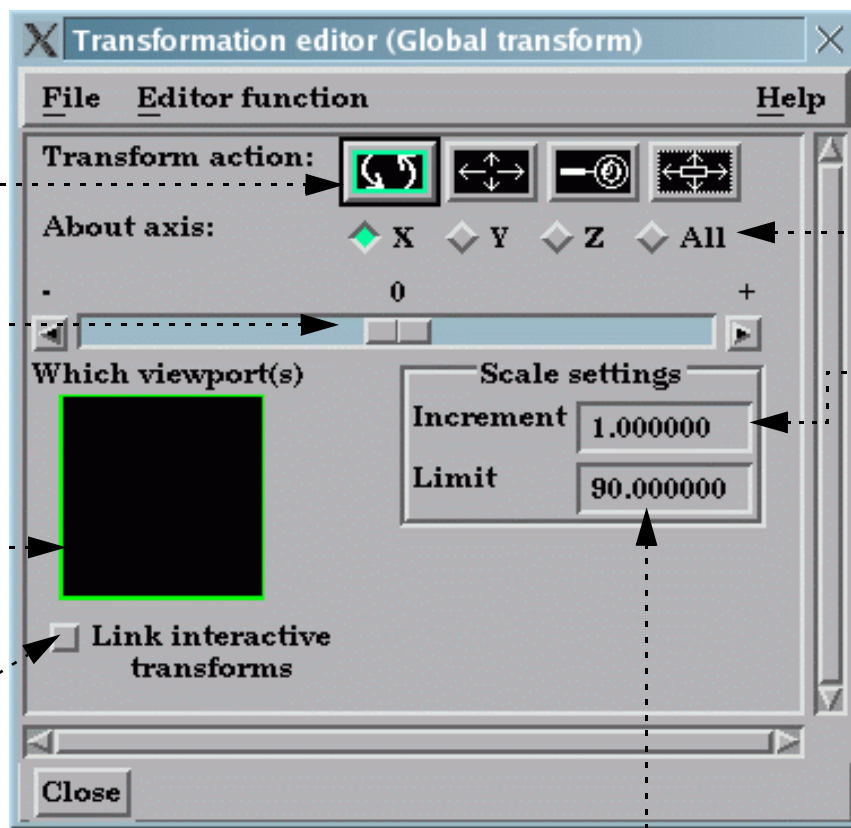

Specify axis to which the transform applies

Increment controls the step size for the slider end arrows.

Enter explicit values in the Increment field (and press return) to transform by a precise amount.

Limit controls the sensitivity and limit of the slider action.

You can also perform scaling in any or all dimensions (to, for example, magnify subtle differences in a surface). Although you cannot perform the scaling operation with the mouse, you can scale using the Transformations dialog. Click the Scale icon in the Transformation Control area and specify the scaling as described above.

You can copy the transformations from one viewport to another. First select the viewport you wish to copy, select Editor Function->Copy Transformation State, then select the viewport(s) you wish to modify and select Editor Function->Paste Transformation State.



OTHER NOTES

By default, EnSight uses the left mouse button for performing the selected transformations. You can, however, program the transformation action attached to each mouse button. See [Customize Mouse Button Actions](#) for more information.

The transformation operations described here also apply to frame transformations. If additional frames have been created and if the mode has been set to Frame, then any transform will apply to the currently selected frame. See [Create and Manipulate Frames](#) for more information.

Pressing the F5, F6, or F7 keys while the mouse is within the EnSight graphics window or desktop area will transform the scene to show a standard right, top, or front view, respectively. Pressing the F8 key will return the scene to that which existed prior to F5, F6, or F7 being pressed. Further, holding the Control key down while pressing F5, F6, or F7 will store the current view to the selected Fx button.

Pressing F9 while the mouse is in the Graphics Window or the desktop area will zoom the display to full screen. Press F9 again to return to the normal display.

SEE ALSO

Other viewing operations: [How To Set LookFrom/LookAt](#), [How To Set Z Clipping](#), [How To Create and Manipulate Frames](#), [How To Reset Tools and Viewports](#), [How To Use the Selection Tool](#).

User Manual: [Global Transform](#), [Frame Transform](#)



Set Drawing Mode (Line, Surface, Hidden Line)

INTRODUCTION

EnSight provides two basic drawing styles for graphics objects: line or shaded. Line mode draws only the line segments of an object – regardless of whether the lines are polygon edges or not. Shaded mode displays all objects consisting of polygons (e.g. element or cell faces) as solid filled regions with light source shading enabled.

These drawing styles can be enhanced by enabling hidden-line mode. If the current mode is line, hidden-line will eliminate all those lines that would be invisible if the object were a solid surface. If the current mode is shaded, hidden-line mode will draw lines overlaying face edges. In shaded mode, hidden-line overlays are particularly useful for visualizing computational grids.

The setting of line or shaded mode is a global toggle. You can also set the mode on a per part basis so that some parts are displayed as lines and others as shaded surfaces. Each **viewport** also provides individual controls so that the drawing mode can differ from viewport to viewport.

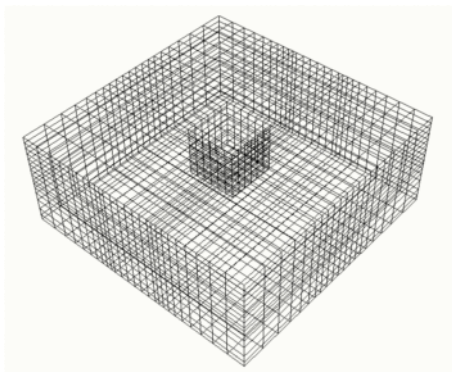

Line mode

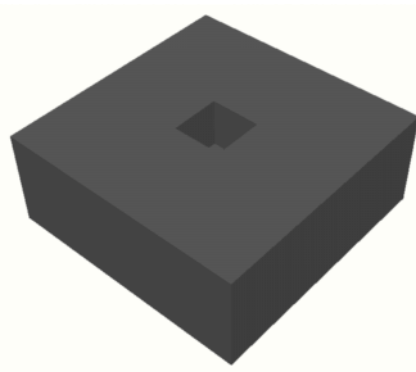

Shaded mode

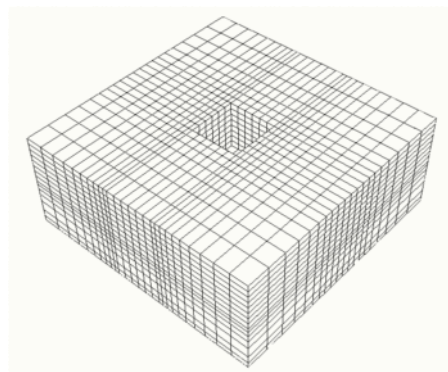

Hidden-line mode

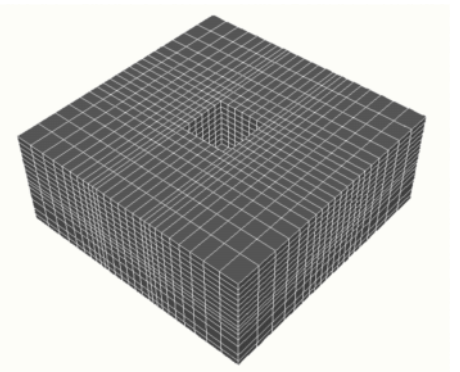

Hidden-line overlay mode

BASIC OPERATION

The global toggles for shaded and hidden-line mode are available from the desktop. You can also enable these modes by selected View > Shaded or View > Hidden Line. To use the desktop toggles:

1. Click the **Shaded toggle** to switch from line to shaded mode (or vice-versa).



2. Click the **Hidden Line toggle** to enable or disable hidden-line mode.



If the current mode is Shaded when you toggle on Hidden Line, the Hidden Line Overlay dialog is displayed. This dialog allows you to specify a color for the overlay edges. If Specify Line Overlay Color is not enabled, overlay color will be set to the native color of each part. If it is enabled, the color can be specified either by entering red, green, blue color values, or by clicking the Mix... button and picking a color with the standard **Color Selector** dialog.

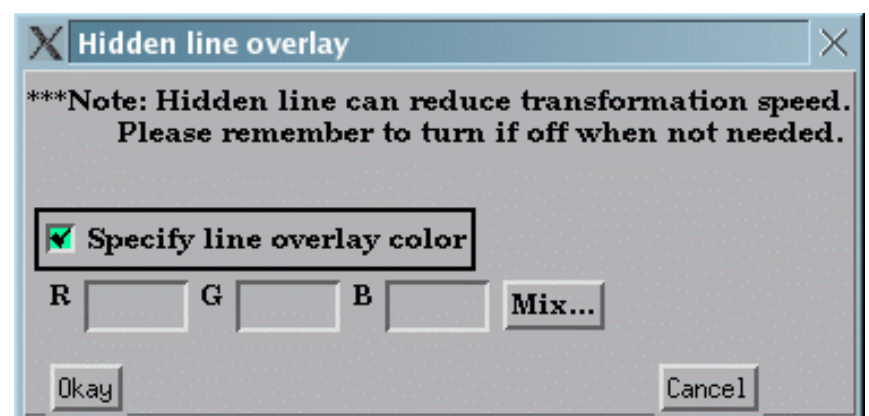

Note that hidden-line and hidden-line overlay are disabled during interactive transformations. The drawing calculations required for these modes can be quite substantial for large models – so much so that interactive manipulation would be unacceptably slow.

Note also that hidden line overlay mode is disabled if transparency is on.



The per-part toggles for shaded and hidden-line mode are available in Part mode.

1. Select Part in the Mode Selection area.
2. Click the Shaded toggle to switch from line to shaded (or vice-versa).
3. Click the Hidden Line toggle to enable or disable hidden-line mode.

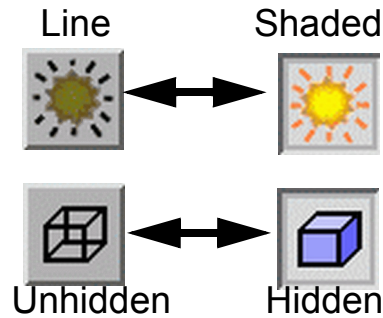

Note that enabling shaded mode for a part has no effect *unless* the global shading toggle is also enabled (on the desktop or under the View menu). The same is true for hidden-line: unless the global hidden-line toggle is enabled, the part will be drawn without hidden lines.

ADVANCED USAGE

Drawing modes can also be set on a per-viewport basis. As with per-part settings, these toggles require that the corresponding global toggle is also set to have any effect.

1. Select VPort in the Mode Selection area.
2. Select (click in) the desired viewport in the Graphics Window.
3. Click Viewport Special Attributes... to open the Viewport Special Attributes dialog.
4. Click the Shaded button to disable shading in the current viewport.
5. Click the Hidden Line button to disable hidden-line in the current viewport.

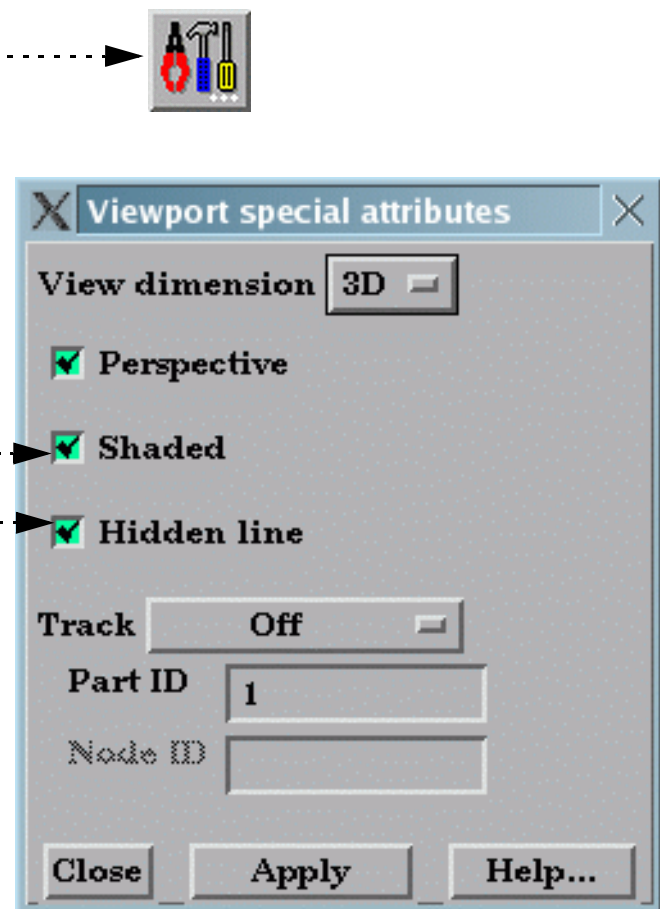

OTHER NOTES

When a part is drawn in shaded mode (with or without hidden-line overlay) the surface is displayed with light source shading enabled. EnSight uses two pre-defined light sources: one at the look-from point (the camera) and one on the opposite side of the model (for back-lighting). The location of one of the light sources can be changed, see [How To Control Lighting Attributes](#).

In computer graphics, the appearance of a shaded surface is governed by a lighting model controlled by various parameters. In EnSight, these parameters are part of the part's attributes and can be changed on a per-part basis. See [How To Set Attributes](#) for more information.

SEE ALSO

[How To Control Lighting Attributes](#)

User Manual: [Global Shaded](#), [Global Hidden Line](#)



Set Global Viewing Parameters

INTRODUCTION

EnSight provides various modes that control global viewing behavior. Three of these modes are discussed here: perspective/orthographic projection, bounding box display modes, and static lighting.

EnSight can display viewports in either *perspective* or *orthographic* projection. A perspective projection is how we normally view the world: objects that are farther away appear smaller. An orthographic projection removes this effect: objects appear the same size regardless of distance. The projection setting can be specified on a per-viewport basis.

By default EnSight draws every point, line, and polygon for every visible part *each* time the Graphics Window updates. For very large models (or slow graphics hardware), this behavior leads to unresponsive manipulations since the update lags behind the corresponding mouse motion. Fortunately, EnSight provides other display modes that improve responsiveness. *Fast Display* mode displays a bounding box around, a point cloud for, polygon reduced version, or if using immediate mode - a percentage only of all visible parts to be displayed during interactive manipulations. When the mouse button is released, parts are drawn normally. The Fast Display mode can also be set such that the bounding display is used until the mode is changed - even when the mouse is released. (Edit->Preferences... Performance - Static Fast Display)

Surface shading operations are expensive for very large models. Since the shading is dependent on the orientation of the model with respect to the light sources, the surface colors must be recalculated each time the model moves. Static lighting mode precalculates surface colors for a given orientation and then uses these colors during subsequent transformations, resulting in improved interactive response.

BASIC OPERATION

Perspective/Orthographic Projection

The projection mode can be toggled either from a menu (View > Perspective) or in the VPort icon bar. To set the projection from the icon bar:

1. Select VPort in the Mode Selection area.
2. Select (click in) the desired viewport in the Graphics Window.
3. Click Viewport Special Attributes... to open the Viewport Special Attributes dialog.
4. Click the Perspective button to toggle the projection type in the current viewport.

Note that a viewport will only display a perspective projection if the global toggle (as set with View > Perspective) is on as well.

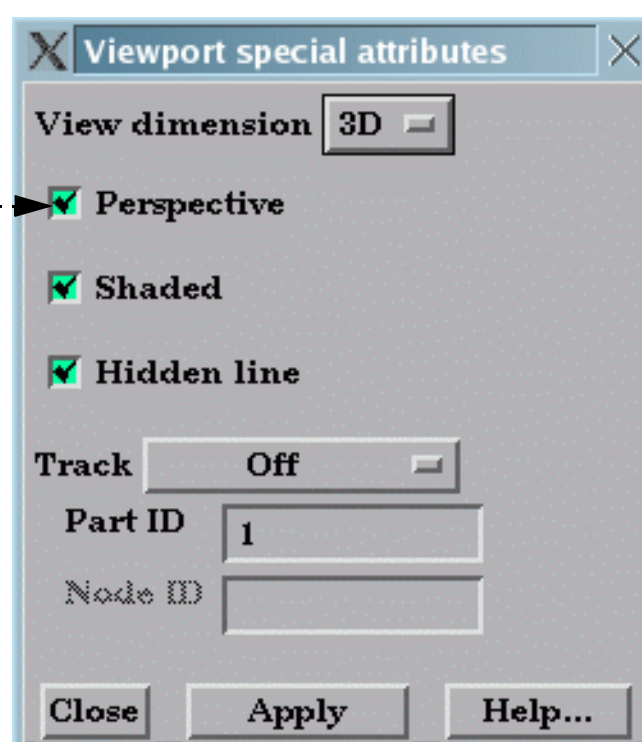
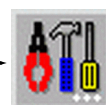



Fast Display Mode

The Fast Display Mode can be set either from a menu (View > Fast Display >) or by the Fast Display toggle on the desktop. To change between the Dynamic or Static operation of this mode, go to Edit->Preferences... Performance. To change the part representation for Fast Display Mode:

1. Click the Fast Display Representation pull-down icon.

2. Select Dynamic Box.

or

3. Select Points.

or

4. Select Reduced poly.

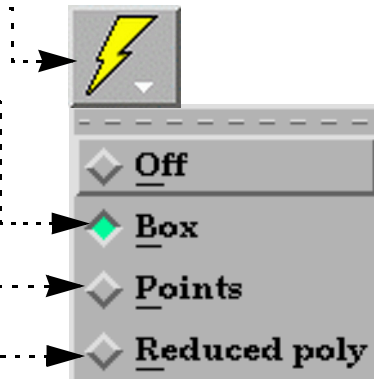

Select Off to return to standard display mode.

Note, if using immediate mode a Sparse Model option will also be available here.

Static Lighting

The Static Lighting setting is only available from the View menu. Select View > Static Lighting to enable or disable static lighting. Although interaction speed is improved in static lighting mode, note that the light source appears to rotate *with* the object. This is often an acceptable trade-off.

ADVANCED USAGE

If using immediate mode, and you desire to use the Sparse Model option for Fast Display, you can control the percentage of the model that is displayed. See [“Performance Preferences”](#). This mode is intended for large models. It generally will not be pleasing (nor should it be needed) for small models.

SEE ALSO

User Manual: See [“Part Mode”](#) and [Static Lighting](#)



INTRODUCTION

As you apply zoom transformations in EnSight, you may have noticed that the model begins to progressively disappear as you move close to the model. This happens when the visible model parts intersect the front *Z clipping planes*. The Z-clip planes (which are always perpendicular to your line of sight) are specified as distances from the look-from point (the camera position). The Z clipping plane positions can be set by the user and can be used to remove unneeded geometry from the display. Each viewport has its own set of Z clipping planes. By default, the Z-clip planes adjust (float) with the model - thus stay out of the way if possible.

BASIC OPERATION

The initial position of the Z clipping planes is set based on the Z (depth) extent of the visible geometry – plus quite a bit extra to leave room for transformations. The plane positions can only be set via the Transformation Editor dialog.

1. In the Transformation Control area, Click Transf... > Editor Function > Z_clip to open the Transformation Editor.

The graphics display shows the relative positions of the front and back clipping planes (left and right vertical red lines) to the Z extent of all currently visible objects (white box).

If the Float Z-Clip Planes With Transform option is on, you can specify the minimum Z value that the Front clip plane can float to.

2. Toggle the Float Z-Clip Planes option on to have the Z-clip planes automatically adjust.
OR
Toggle the option off to manually adjust the Z-clip plane locations.

If the Float Z-Clip option is off, you can edit the plane positions either by dragging the red lines or by entering explicit values in the Front and Back text fields. Recall that the values represent the distance from the look-from point to the plane.

3. Place the mouse pointer over the desired plane marker and click the left mouse button.
4. Drag the marker left or right to the desired location. The Graphics Window will update as the marker is moved.
– OR –
3. Enter explicit values in the Front and/or Back text fields and press return.

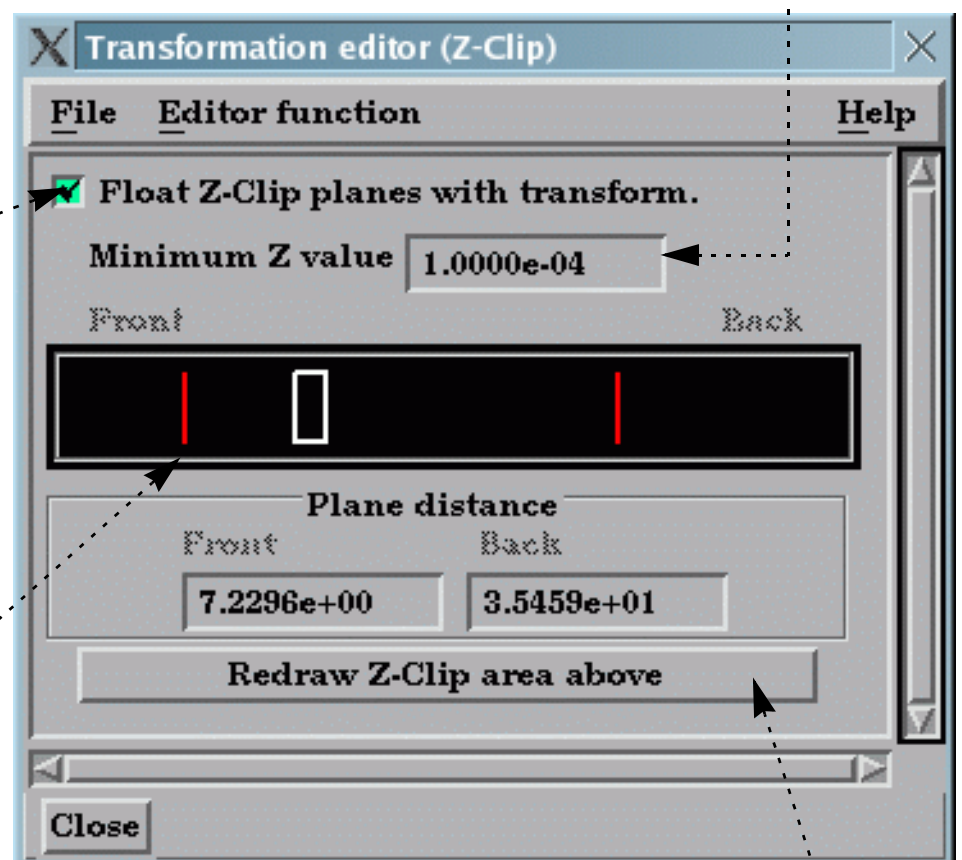

If the markers become difficult to manipulate due to changes, click the Redraw Z-Clip Area Above button to rescale the markers.

Each viewport maintains its own independent Z clipping planes. The operation described above will change the planes for the current viewport (as set by clicking in the desired viewport in the Graphics Window).

Note that clicking Reinitialize, in the Reset Tools and Viewport(s) dialog found under the Reset... button of the Transformations area, will reset the Z clipping planes of the current viewport based on the Z extent of all objects currently visible in that viewport.

OTHER NOTES

EnSight uses your workstation's graphics hardware to implement Z clipping. The same hardware is used for *Z-buffering* – determining which objects are visible based on Z (depth) values. The Z buffer typically provides 24 bits of resolution. EnSight attempts to make the best use of this limited resolution by setting the front and back clipping planes reasonably close together. If the planes are too far apart, relative Z resolution is reduced and the hardware



may not be able to accurately determine surface visibility. If you see artifacts like this, move the clipping planes closer together.

EnSight also provides an additional clipping plane: the auxiliary clipping plane. Unlike the Z clipping planes which are always perpendicular to your line of sight, the auxiliary clipping plane can be placed at any location in any orientation. The Plane Tool specifies the location of the auxiliary clipping plane. By default, all geometry on the negative Z side of the Plane Tool is removed. However, you can specify auxiliary clipping on a per part basis – some parts are clipped while others are not. See [How To Set Auxiliary Clipping](#) for more information.

SEE ALSO

[How To Define and Change Viewports](#), [How To Set Auxiliary Clipping](#)

User Manual: [Z-Clip](#)





Set LookFrom / LookAt

INTRODUCTION

In addition to providing control over model manipulations, EnSight also provides control over the virtual camera used to view the scene in the Graphics Window. The two control parameters are the *look-from* point (the position of the camera) and the *look-at* point (a point on the camera's line-of-sight vector). The Global Axis is positioned at the look-at point and is always in the center of the Graphics Window.

Initially, the look-at point is set to the geometric center of all visible objects and the look-from point is set to a point on the positive Z axis such that all visible objects fit in the Graphics Window (as shown in the top image below). The white axis triad is the Global Axis and can be displayed by selecting View > Axis Visibility > Axis - Global. The bottom image shows the view after the look-from point has been repositioned between the X and Z axes. The diagrams to the right of each image show a top-down schematic of each viewing case.

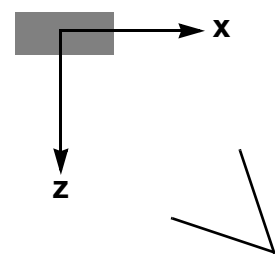
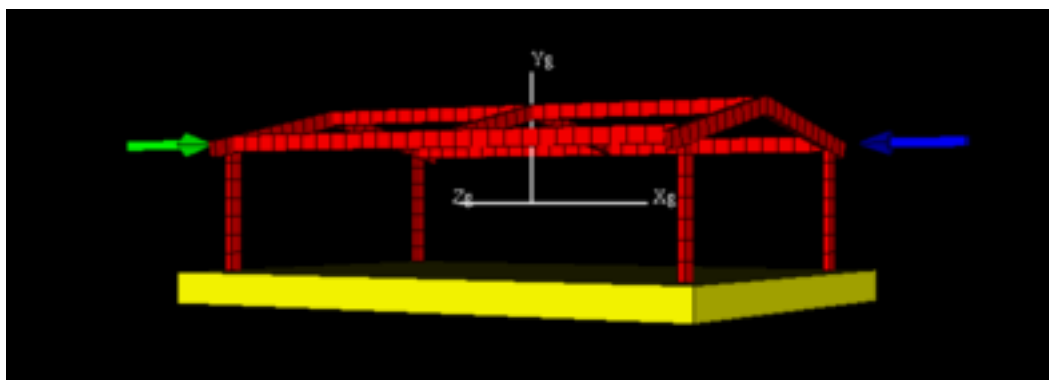
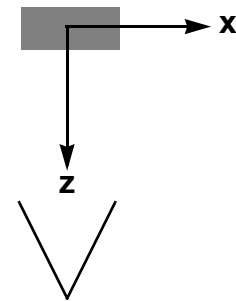
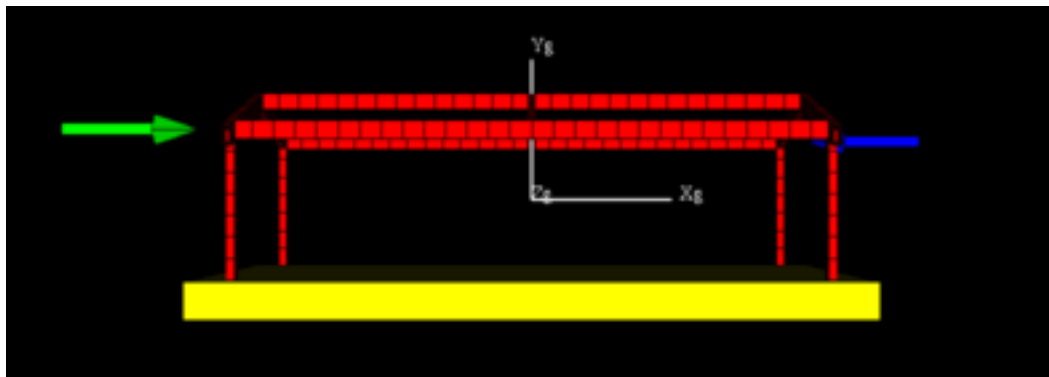

BASIC OPERATION

The look-from, look-at points are controlled via the Transformation Editor dialog.

1. Click Transf... in the Transformation Control Area.
2. Select Editor Function > Look At/Look From.

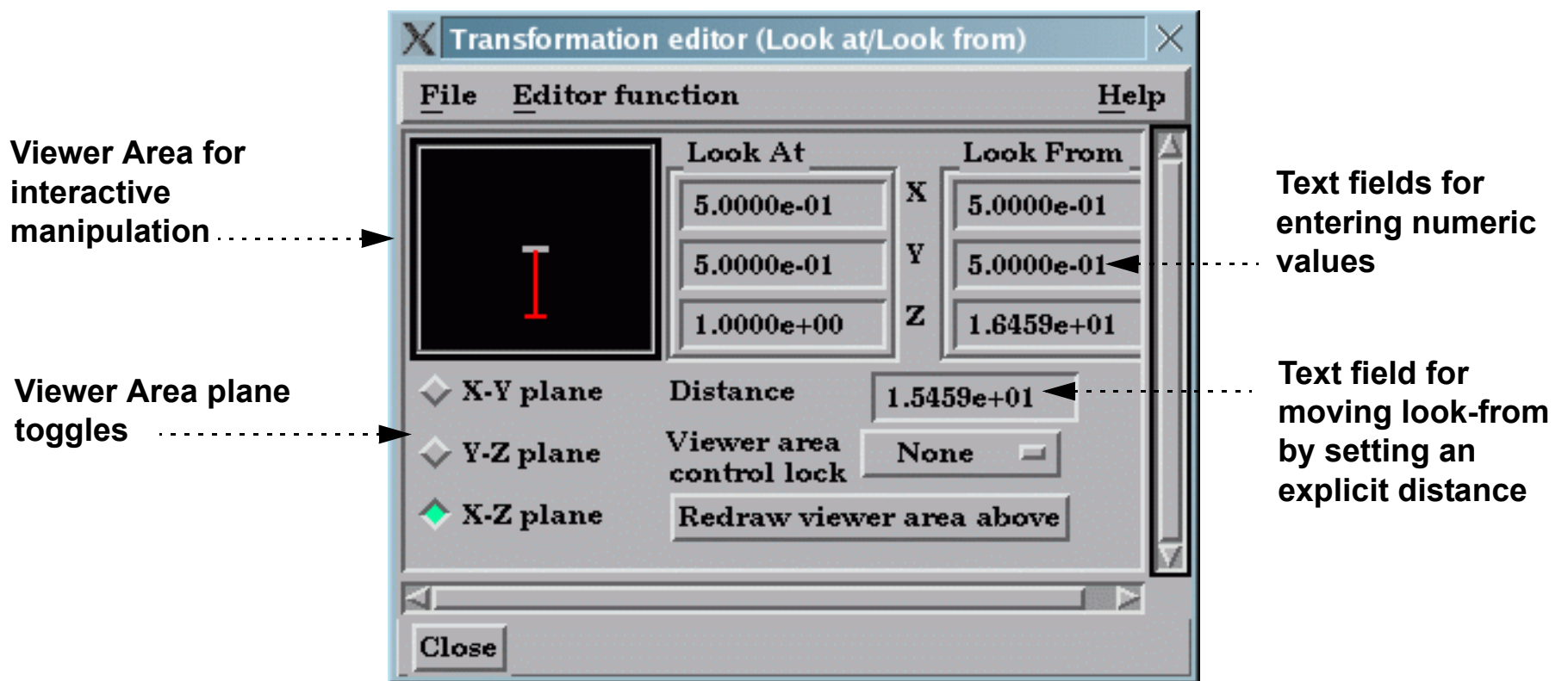

The Transformation Editor dialog provides two methods for setting the look-at and look-from points. Numeric values can be entered directly into the X,Y,Z Look At, Look From text fields (remember to press return). You can also enter a value in the Distance field to explicitly move the look-from point a certain distance away from the look-at point.

Alternately, the Viewer Area can be used to interactively manipulate the points. The presentation of the Viewer Area depends on the which plane toggle is set: X-Y (view from the positive Z axis), Y-Z (view from the positive X axis), or X-Z (view from the positive Y axis – the default). In each case, the gray box represents the extent of all visible parts. The intersection of the two red lines is the look-from point. The opposite end of the long red line is the look-at point (which is initially near the center of the gray box). The example below shows the X-Z Plane presentation, the others behave analogously.

To change the look-from point:

1. Place the mouse pointer over the intersection of the two red lines.
2. Click and drag to the desired location. Note that the Graphics Window updates as the look-from point is moved.

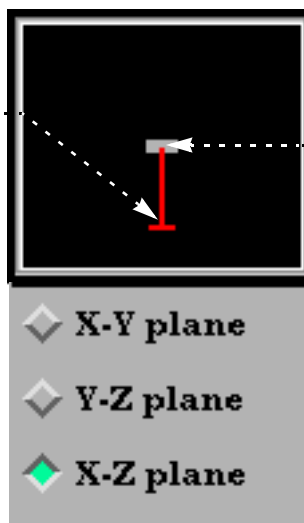

To change the look-at point:

1. Place the mouse pointer over the free end-point of the long red line.
2. Click and drag to the desired location. Note that the Graphics Window updates as the look-at point is moved.

During your manipulation, the display in the View Area may become difficult to use. Click the “Redraw Viewer Area Above” button to rescale the display.

The Viewer Area Control Lock pull-down menu effects interactive operation in the Viewer Area as follows:

- None* No constraints are placed on movement of either the look-from point or the look-at point.
- Distance* Movement of the look-from (look-at) point is restricted to a circle whose radius is the current Distance value and whose center is the look-at (look-from) point.
- Together* The movement of both points is locked such that movements applied to one are applied to the other.

You can easily reset the look-from and look-at points such that all currently visible parts are displayed. Click Reset... in the Transformation Control area to open the Reset Tools and Viewports dialog. Click the Reinitialize button to reset the currently selected viewports.



OTHER NOTES

You can also set the look-at point by picking an object with the mouse in the Graphics Window:

1. Click **Reinitialize** in the **Reset Tools and Viewport(s)** dialog to clear all global transformations.
2. Click the **Pick** button in the global area above the graphics window on the desktop.
3. Select **Pick Look/At Point** from the **Pick Pull-down** icon.
4. Move the mouse into the **Graphics Window**. Place the mouse pointer over the point you wish to set to the look-at point and press the 'p' key (or whatever mouse button you have set for "Selected Pick Action" in **Edit > Preferences > Mouse and Keyboard**).

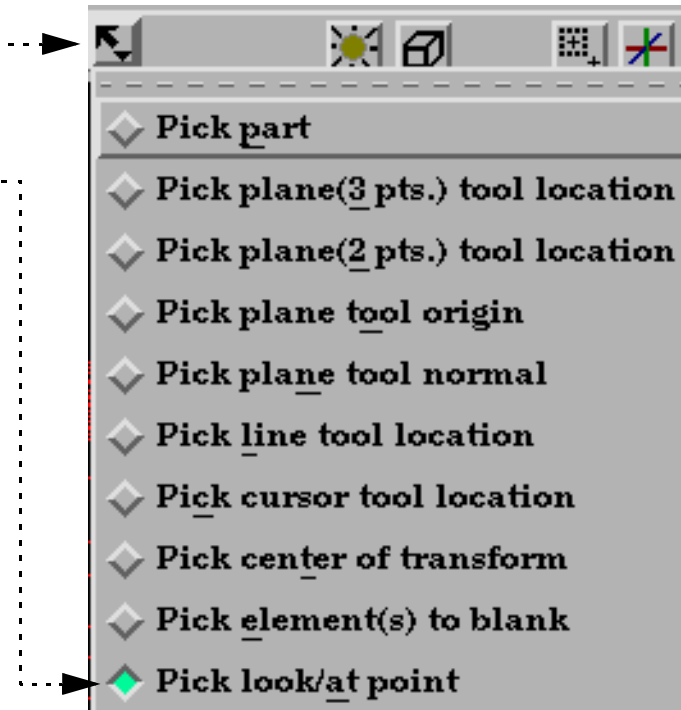

Other camera parameters, such as the camera up direction and the field-of-view angle, cannot be set in this release.

SEE ALSO

[How To Define and Change Viewports.](#)

User Manual: [Look At/Look From](#)



Set Auxiliary Clipping

INTRODUCTION

Unlike standard **Z clipping** where the front and back planes are always perpendicular to your line of sight, auxiliary clipping lets you clip parts against a plane with arbitrary position and orientation. In addition, the auxiliary clip attribute can be set on a per-part basis. This permits selective clipping to reveal objects of interest.

EnSight's **Plane Tool** is used to provide the location for auxiliary clips. As the Plane Tool is manipulated (either interactively with the mouse or via the Transformations dialog), the display in the Graphics Window updates to reflect the new location of the plane.

BASIC OPERATION

Auxiliary clipping can be globally enabled by selecting it in the View menu:

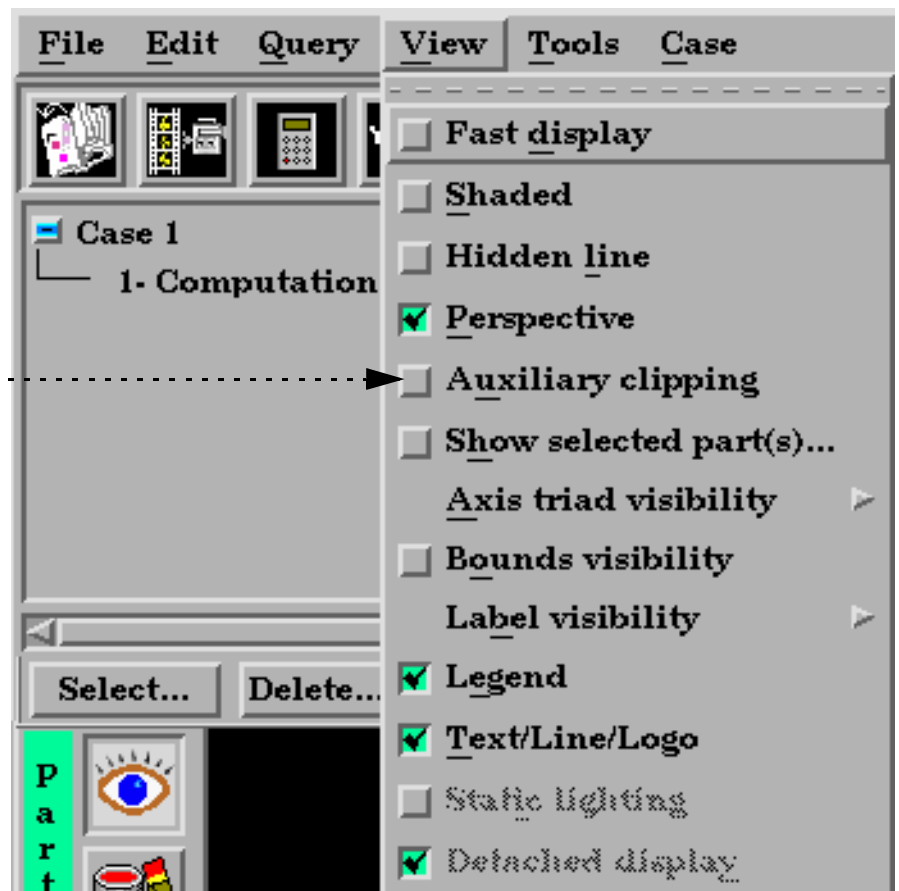

The Plane Tool will become visible and all objects on the negative Z side of the plane will be clipped (assuming the plane currently intersects some visible part). You can now manipulate the Plane Tool to achieve the desired display effect (see [How To Use the Plane Tool](#) for details). Note that Auxiliary Clipping always uses the infinite extent of the plane specified by the Plane Tool – there is no way to restrict it to the rectangular bounds of the tool.

Each part has an attribute that controls whether it is clipped by the Auxiliary Clipping plane or not. To toggle this setting:

1. Select the desired part (see [How To Select Parts](#)).
2. Select Part Mode in the Mode Selection area.
3. Click the Auxiliary Clipping toggle.

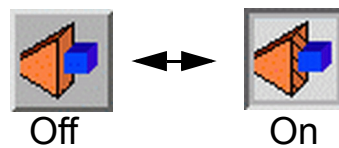

(This attribute can also be toggled in the Feature Detail Editor dialog for the part. See [How to Set Attributes](#) for more information.)

SEE ALSO

[How To Use the Plane Tool](#), [How To Set Z Clipping](#).

User Manual: [Part Auxiliary Clipping](#), [Global Auxiliary Clipping](#)

INTRODUCTION

EnSight provides up to sixteen user-defined viewports in the Graphics Window. Each viewport is a rectangular region of the screen (with or without a border) displaying some or all of the currently visible parts. Each viewport can be transformed (e.g. rotated or zoomed), sized, and positioned independently. Viewports have several display attributes including background and border color. Viewports provide a very flexible environment for data display.

This article is divided into the following sections:

- [Create a New Viewport](#)
- [Select Viewports](#)
- [Move and Resize Viewports](#)
- [Set Viewport Background Color or Image](#)
- [Set Viewport Attributes](#)
- [Display Selected Parts in Viewports](#)
- [Set Case Visibility Per Viewport](#)
- [Perform Transformations in Viewports](#)
- [Reset Viewport Transformations](#)
- [Delete Viewports](#)

BASIC OPERATION

Create a New Viewport

On startup, EnSight creates a single viewport that fills the Graphics Window. To create a new viewport:

1. Click **VPort** in the **Mode Selection** area to enter **Viewport mode**.

2. Click the **Viewports Layout** pull-down icon to select any of the standard viewport layouts.



OR

2. Click the **New Viewport** icon.



Select Viewports

When you create a new viewport, it automatically becomes the *currently selected viewport* (as shown by the border drawn in the default highlight color). Any action to change viewport attributes always operates on the currently selected viewport(s). To select viewports:

1. Click **VPort** in the **Mode Selection** area to enter **Viewport mode**.
2. Move the mouse pointer into the **Graphics Window** and click the left mouse button anywhere within the desired viewport. You can add to an existing selection by holding down the **Control** key as you click in additional viewports.

To select all viewports, click the icon:



Note that the selected viewport is also changed in other modes (such as **View**) any time you perform some action in a viewport (such as rotation). There is however, no visual feedback of this change until you enter **VPort** mode again.



Move and Resize Viewports

Viewports can be easily moved and resized. You can either reposition a viewport with the mouse in the Graphics Window, or precisely by entering exact values. To move or resize a viewport:

1. Click VPort in the Mode Selection area to enter Viewport mode.
2. Select the desired viewport.
3. To move a viewport, move the mouse pointer into the Graphics Window and into the selected viewport. Click and hold the left mouse button and drag the viewport to the desired location.
4. To resize a viewport, move the mouse pointer into the Graphics Window and place it over one corner of the selected viewport. Click and hold the left mouse button and drag the corner to the desired location.

To precisely reposition a viewport:

3. Click the Viewport Location Attributes icon to open the Viewport Location Attributes dialog.



4. Enter new values in the Origin X,Y, Width, or Height fields (and press return).

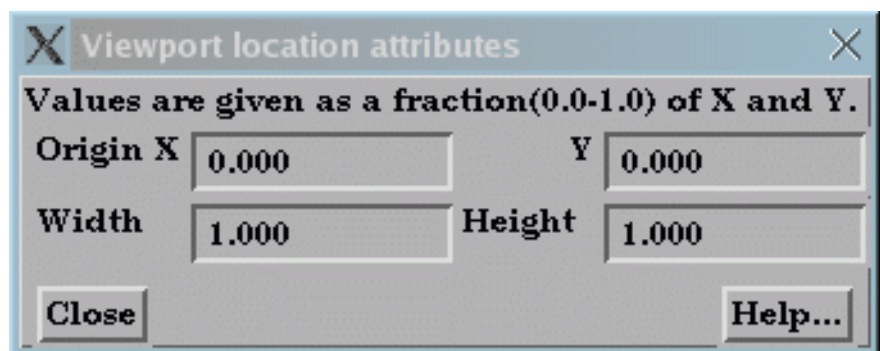

The origin (at 0,0) is the lower left corner of the Graphics Window. Note that the values are normalized to the width and height of the default viewport (*i.e.* the Graphics Window).

EnSight permits overlapping viewports. You can control the ordering (from front to back):

- Click The Viewport Forward icon to bring the selected viewports to the top.

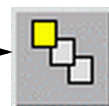

- Click The Viewport Back icon to send the selected viewports to the bottom.

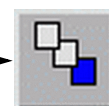

Note: Viewport 0 is always displayed first, thus it cannot be pushed or popped with these icons.



Set Viewport Background Color or Image

Viewport background colors can be constant, blended, or inherited from the default viewport. To set viewport background color:

1. Click VPort in the Mode Selection area to enter Viewport mode.
2. Select the desired viewport(s).
3. Click the Color icon to open the Viewport Background Color Attributes dialog.

The Type pull-down controls the type of background coloring used. There are four types: Constant, blended, inherit, and image.

Constant

A constant color will be used for the entire background. To set a constant color:

4. Select Constant from the Type pull-down.
5. Either enter values in the RGB color fields (and press return OR click the Mix Color... button to open the Color Selector dialog.

6. Click Refresh Viewport.

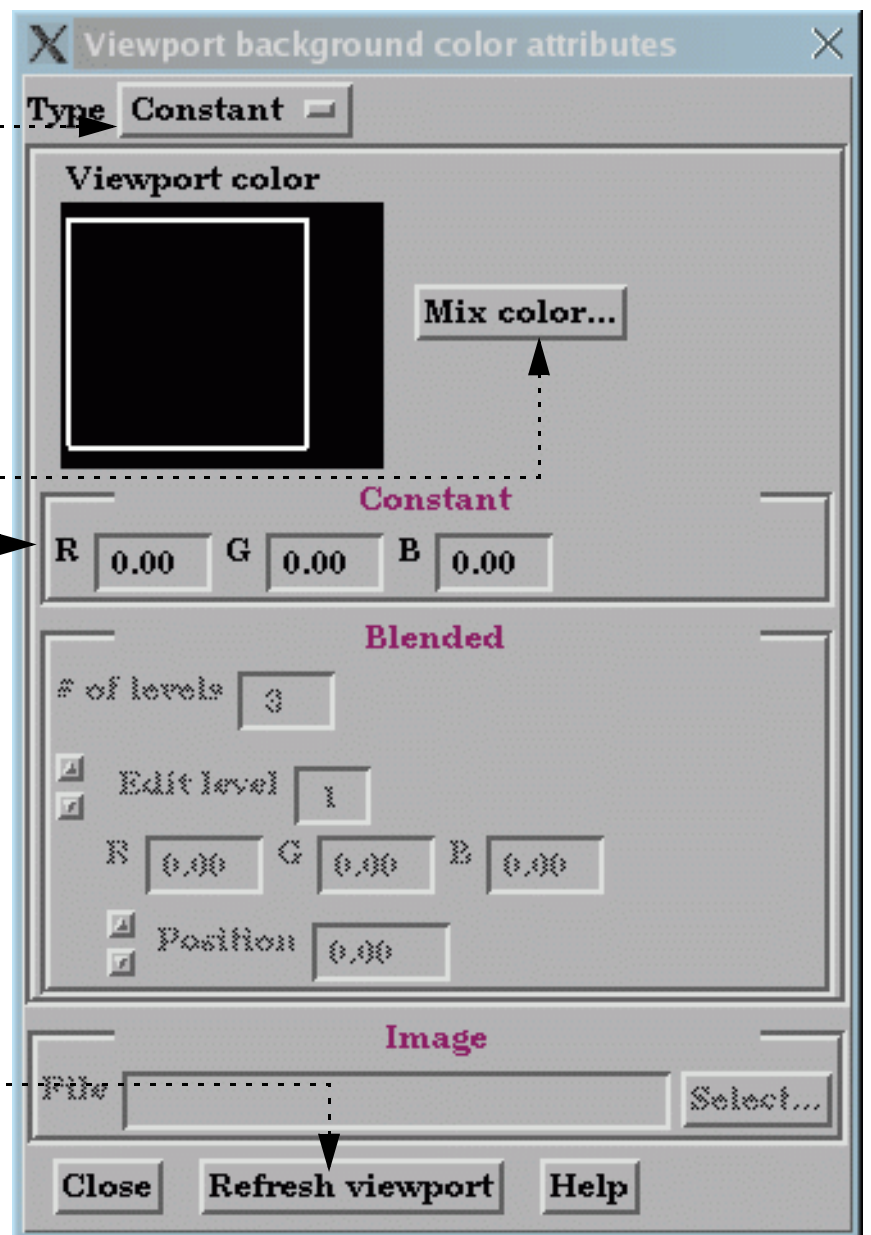



Blended

Up to 5 horizontal level colors can be specified with interpolation between levels. To set a blended background:

1. Select Blended from the Type pull-down.

2. Enter the desired number of levels in the # of Levels field (and press return). Up to five levels are supported.

3. To edit a color, first select it by clicking on the number label in the Viewport Color window. As shown, level 2 is currently selected. Alternately, you can enter a value in the Edit Level field or click the up/down arrows.

4. Change the selected color by either entering new values in the RGB fields (and pressing return) or clicking the Mix Color... button to open the Color Selector dialog.

5. You can also change the relative vertical position of a level by either clicking on the level number with the left mouse button and dragging up or down OR by entering a new value in the Position field (and pressing return).

6. Click Refresh Viewport.

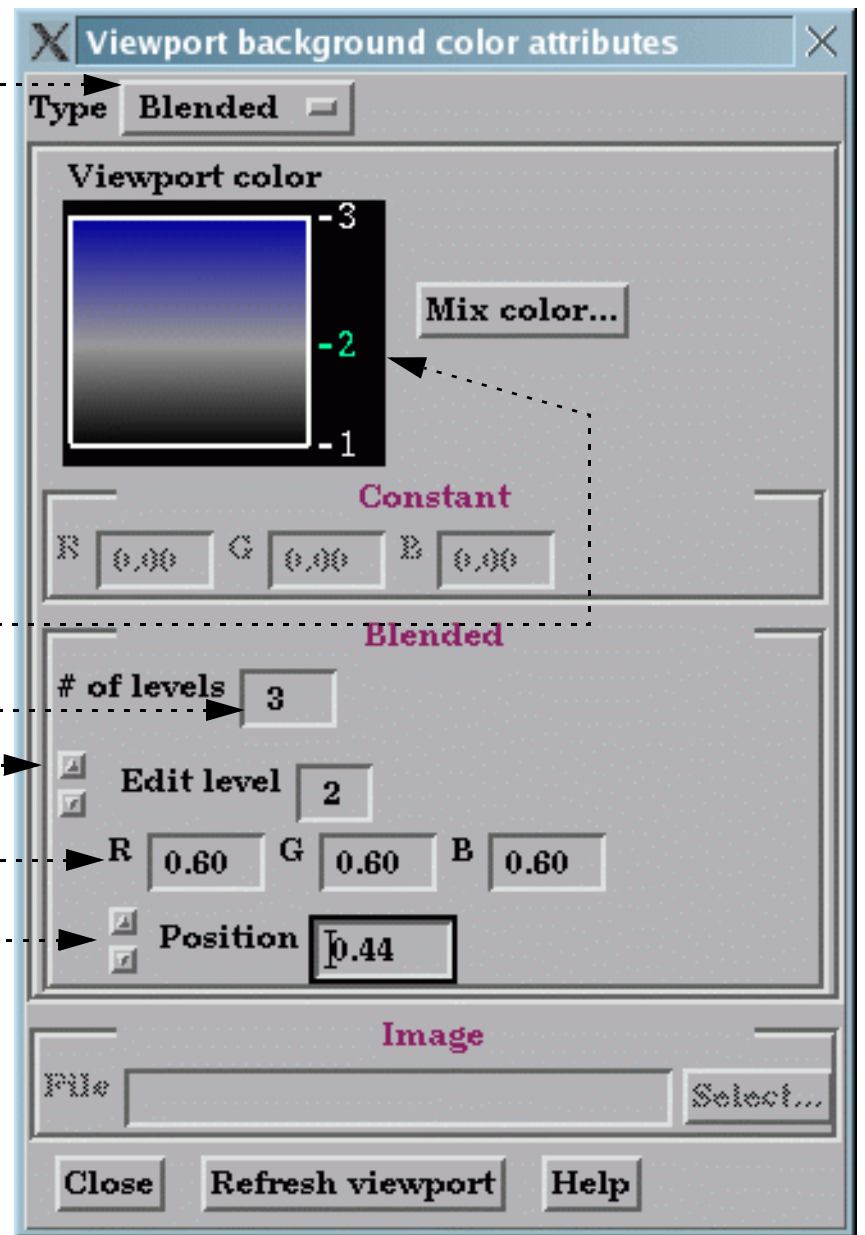

Inherit

The selected viewports inherit the background type and color from the default viewport. To set an inherited background:

1. Select Inherit from the Type pull-down.

2. Click Refresh Viewport.

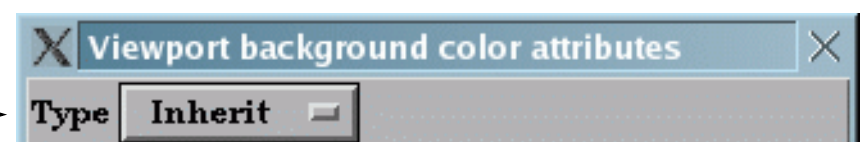

Image

The selected viewports inherit the background type and color from the default viewport. To set an inherited background:

1. Select Inherit from the Type pull-down.

2. Enter the filename for the background image to use or click the Select... button and navigate to it.

Note, that the image must be either a .xpm or .bmp file.

2. Click Refresh Viewport.

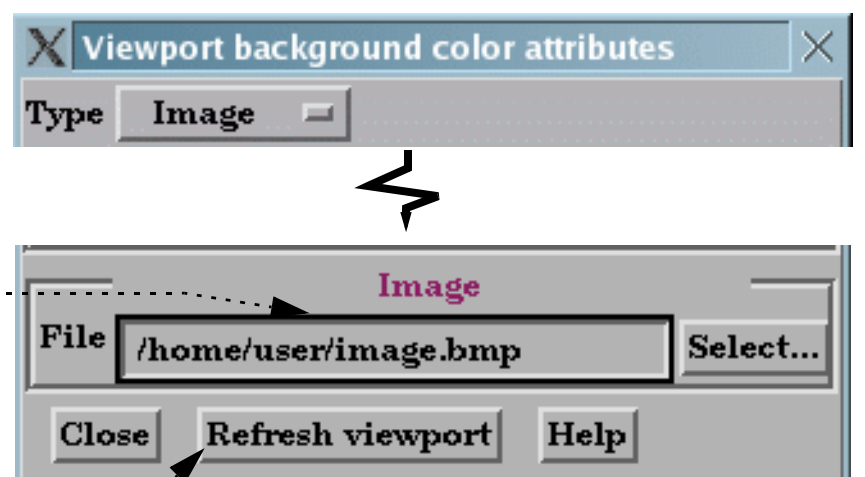



Set Viewport Attributes

Viewports can be displayed with a variety of attributes:

1. Click VPort in the Mode Selection area to enter Viewport mode.
2. Select the desired viewport(s).
3. Set the desired attribute as described below:

Click the Viewport Visibility Toggle to toggle display of the selected viewports on or off (when not in VPort Mode).

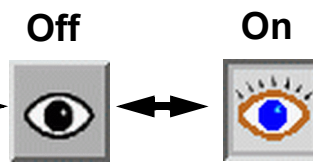

Click the Viewport Border Attributes icon to open the Viewport Border Attributes dialog.



Click the Visible toggle to display a border.

Enter values in the RGB fields (and press return) or click the Mix... button to open a Color Selector dialog.

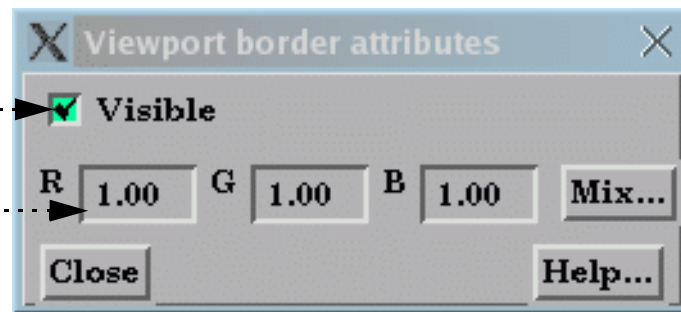

Click the Viewport Special Attributes icon to open the Viewport Special Attributes dialog.

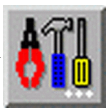

Each viewport has its own toggles for perspective, hidden surface, and hidden line drawing styles. These controls will toggle the respective attribute for the selected viewports. See [How To Set Drawing Style](#) and/or [How To Set Global Viewing](#) for more information.

In addition, a viewport can be 3D or 2D in nature. If the viewport is designated as 2D, only planar parts may be displayed in the viewport and transformations will become 2D limited.

A viewport can be set such that it will track a node number, a part centroid, or one of the part min or max values. Thus as a model changes in time, the viewport will stay centered on that location. See [How To Do Viewport Tracking](#) for more information.

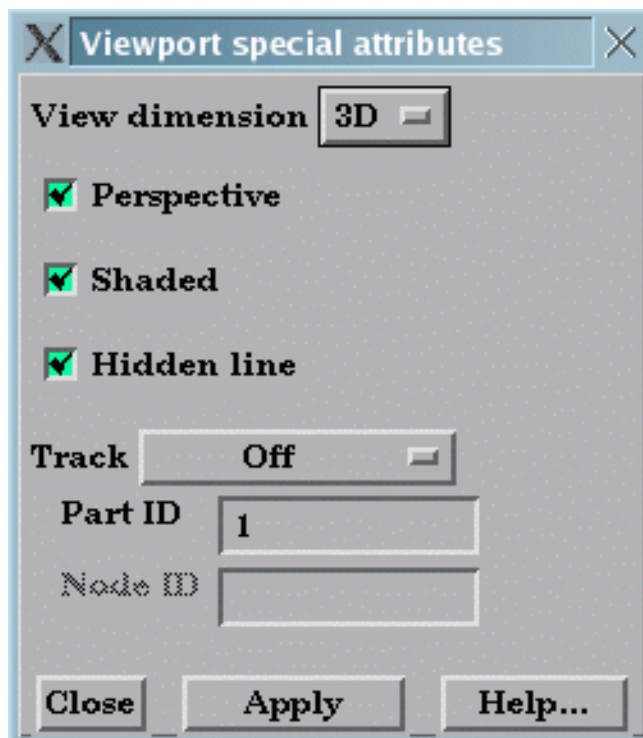

Display Selected Parts in Viewports

Part visibility can be set on a per-viewport basis such that some parts are visible in some viewports but not in others. To set part visibility per viewport:

1. Select the desired part(s) in the Main Parts list.

2. Click the Part Visibility in Viewport Toggle icon.....

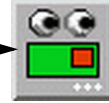

The Part Visible in Which Viewport? dialog displays a schematic of the current viewports. The part is currently visible in the green viewports but invisible in the black viewports.

3. Click in a green viewport to disable display of the selected part(s) in that viewport OR click in a black viewport to enable display of the selected part(s) in that viewport.

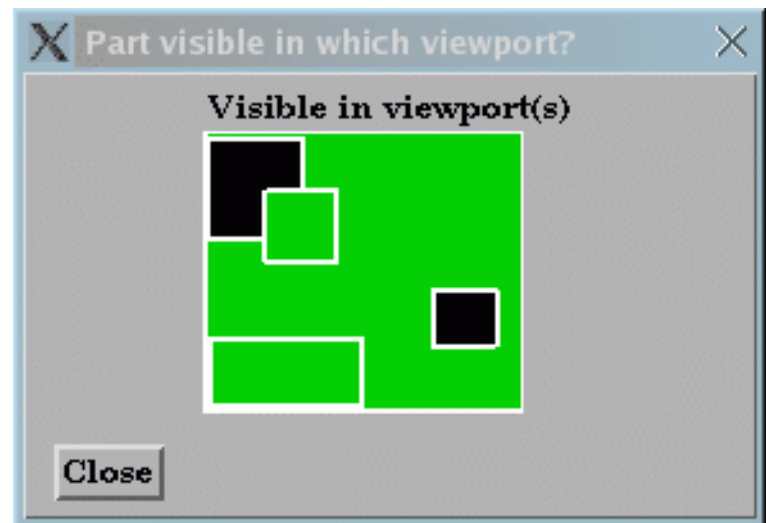

Note that a similar interface for setting this attribute appears in the General Attributes section of the Feature Detail Editor dialog.

Set Case Visibility Per Viewport

If you have multiple **cases** in your session of EnSight, you can set viewport visibility for all parts associated with a case. This makes it easy to display one case per viewport. To set case visibility per viewport:

1. Select the desired case from the Case menu (Case > *casename*).

2. Select Case > Viewport Visibility to open the Case Visible in Which Viewport? dialog.

3. Click in a green viewport to disable display of the selected case in that viewport OR click in a red viewport to enable display of the case in that viewport.

Perform Transformations in Viewports

You can transform objects in a user-created viewport as easily as in the default viewport (See [How To Rotate, Zoom, Translate, Scale](#) for details). For precise viewport transformations, you can use the Transformations Editor on a per viewport basis:

1. Click Transf... in the Transformations Control area.

2. To perform precise transformations in a viewport, click the desired viewport in the Which Viewport(s) window and perform the transformation.

To select more than one viewport, simultaneously hold down the control key and click on additional viewports.

Note that this action will change the currently selected viewport(s).

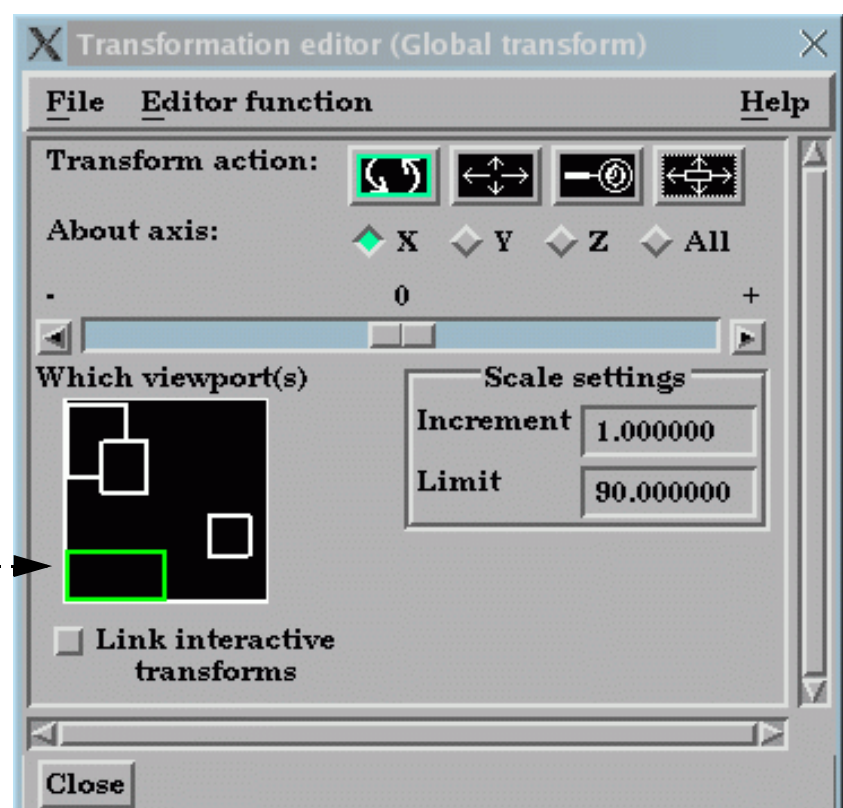

Reset Viewport Transformations

The transformations for one or more viewports can be reset at any time in the Reset Tools and Viewports dialog.



1. Click the **Reset...** button on the bottom of the desktop.

2. Select the viewport(s) on which the reset will act.

3. Click on the appropriate button to perform the reset action desired.

You can reset the selected action only, all rotates translates and scales at once, or do a complete reinitialization of the viewport.

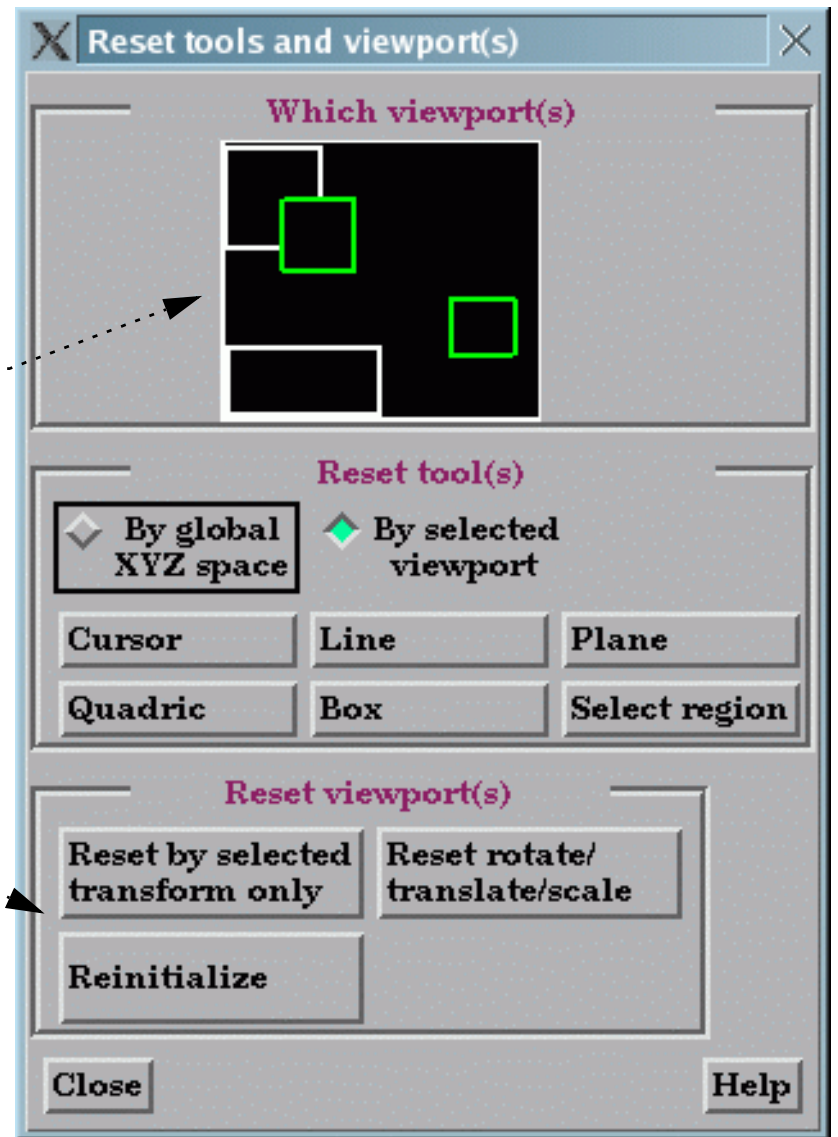

Setting/Changing Viewport Part Bounds

Part bounds can be displayed within a viewport. This is useful for understanding the size of the model domain.



1. To turn on part bounds globally, toggle the **Bounds** button on.

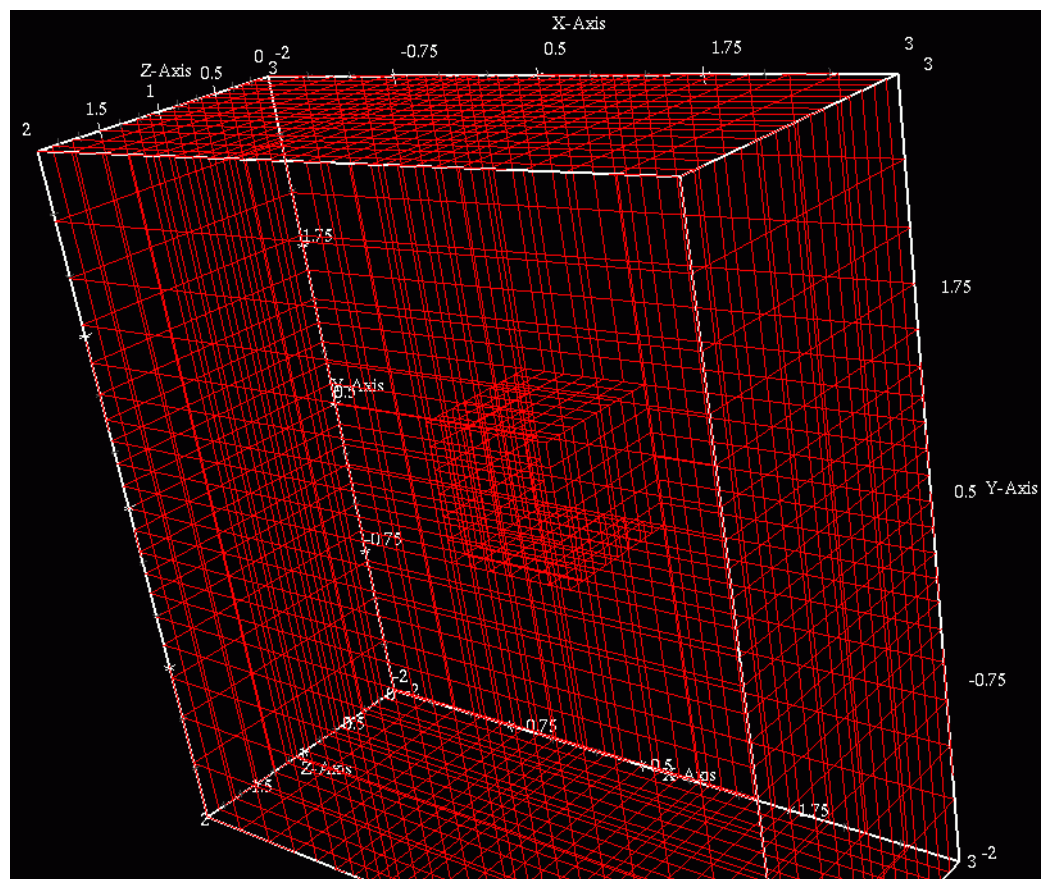



2. To modify, in Vport mode, any of the settings for the bounds display, click the Select Viewport(s) Part Bounds Attributes icon.



3. Select General or the XYZ axes tabs.

4. Modify any attributes desired.

Including the visibility toggle if you don't desire to see the bounds in the selected viewports.

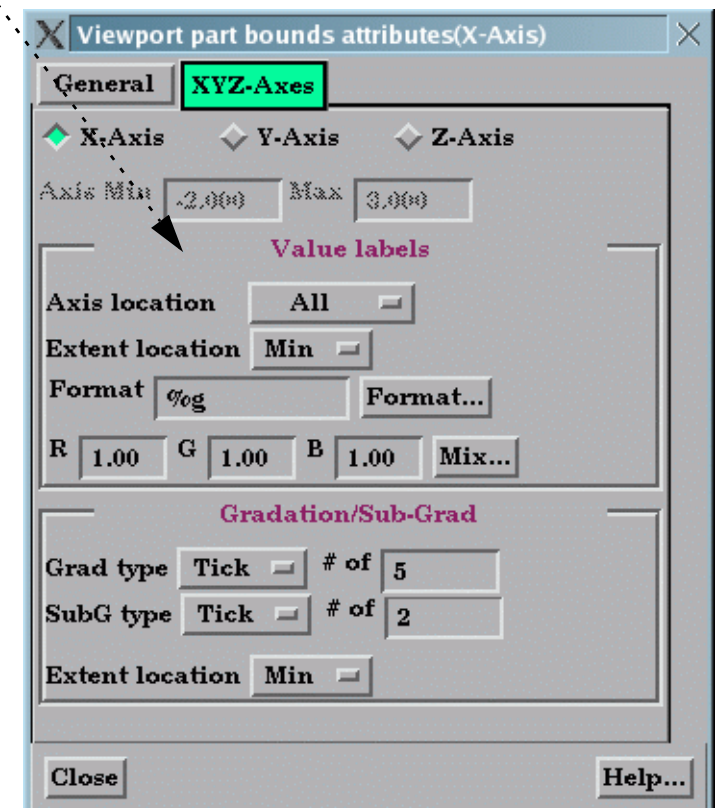
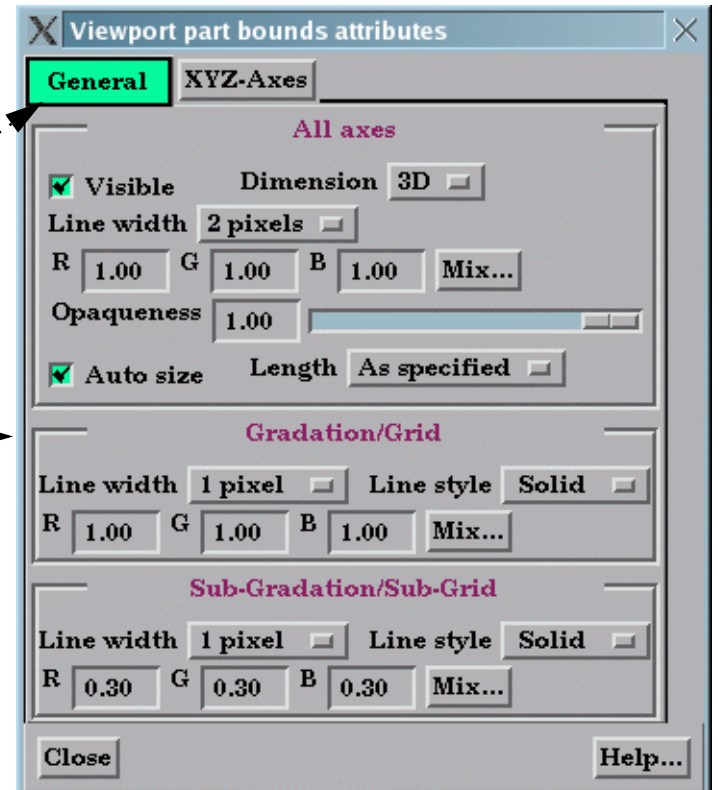

Delete Viewports

A created viewport can be deleted at any time:

1. Click VPort in the Mode Selection area to enter Viewport mode.
2. Select the desired viewport(s).
(Hold down the control key to select multiple viewports)
3. Click the Delete icon.



Other Notes

You can interactively transform multiple viewports simultaneously by selecting the viewports you want to link together and turning on the Link Interactive Transforms toggle. Those viewports that are highlighted in green will now transform together for any transformations performed in the Transformation dialog. Linking does not apply to transformations performed by the mouse in the graphics window.

You can copy the transformations from one viewport to another. First select the viewport you wish to copy, then select Editor Function->Copy Transformation State. Next select the viewport(s) you wish to modify and select Editor Function->Paste Transformation State.





SEE ALSO

[How To Rotate, Zoom, Translate, Scale, How To Control Lighting Attributes](#)

User Manual: [VPort Mode](#)



INTRODUCTION

EnSight allows control over the location of the light source for each viewport. This location is specified in terms of Azimuth and Elevation relative to the viewport or in what is called “absolute position” - which is relative to the model coordinate system. A intensity of a second light source can also be set, but its position is always at the viewer’s (camera’s) location.

BASIC OPERATION

To specify the available lighting attributes In EnSight:

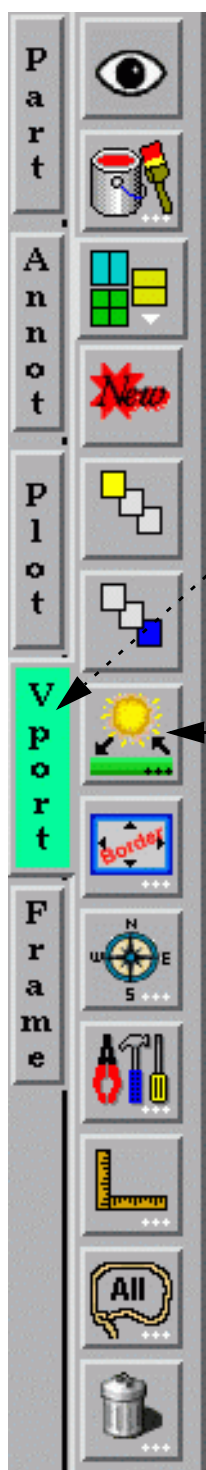

1. Click Vport mode.
2. Select the viewport(s) for which you want to modify the lighting attributes.
3. Click the Selected viewports lighting button.
Which will bring up the Viewport lighting attributes dialog.
4. Choose whether lighting will be relative to the viewport (Relative) or relative to the model axis system (Absolute).

5. Manipulate the position of Light 1 by typing in Azimuth and Elevation or using the sliders.

6. If desired, also modify the intensity of Light 2 (which is at the viewer’s location).

If you are in Relative position mode, you can convert to Absolute by clicking.

Note that one can easily set the light(s) back to the default settings.

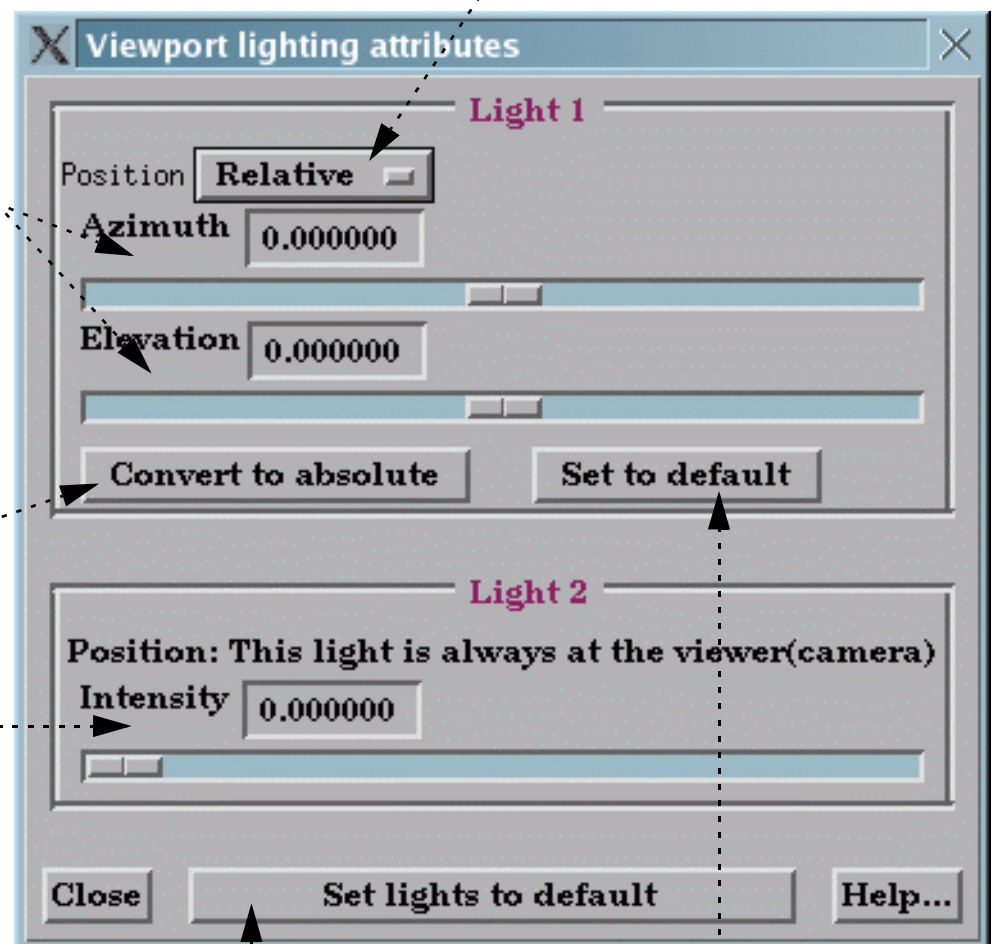

The effect of using a Relative position, is that when the model is rotated - the light source does not rotate - so lighting changes on the model.

The effect of using an Absolute position, is that when the model is rotated - the light source rotates with the model - so lighting on the model does not change.

SEE ALSO

User Manual: [Lighting Attributes](#)



Display Remotely

INTRODUCTION

EnSight **does not** support the running of the client on one machine and setting the system display environment back to a different machine. ***It is intended that you actually run the client from the console of the client machine.***

The server(s) can of course be run on remote machine(s).

And, of course the various VR combinations of display are valid.

SEE ALSO

[How To Use Server of Servers](#)

[How To Setup for Parallel Rendering](#)



INTRODUCTION

EnSight's viewports provide a great deal of flexibility in how objects are displayed in the Graphics Window. Given the complicated transformations that can be performed, it is imperative that users be able to save and restore accumulated viewport transforms.

BASIC OPERATION

View saving and restoring is accessed from the Transformations dialog.

Saving Viewing Parameters

Click **Transf...** in the Transformations Control area to open the Transformations dialog.

1. Select the viewports you want to save. Click within a viewport to select it. Hold down the control key as you click to select additional viewports.
2. Select **Save View...** from the File menu. Select a directory and enter a file name in the file browser and click OK.

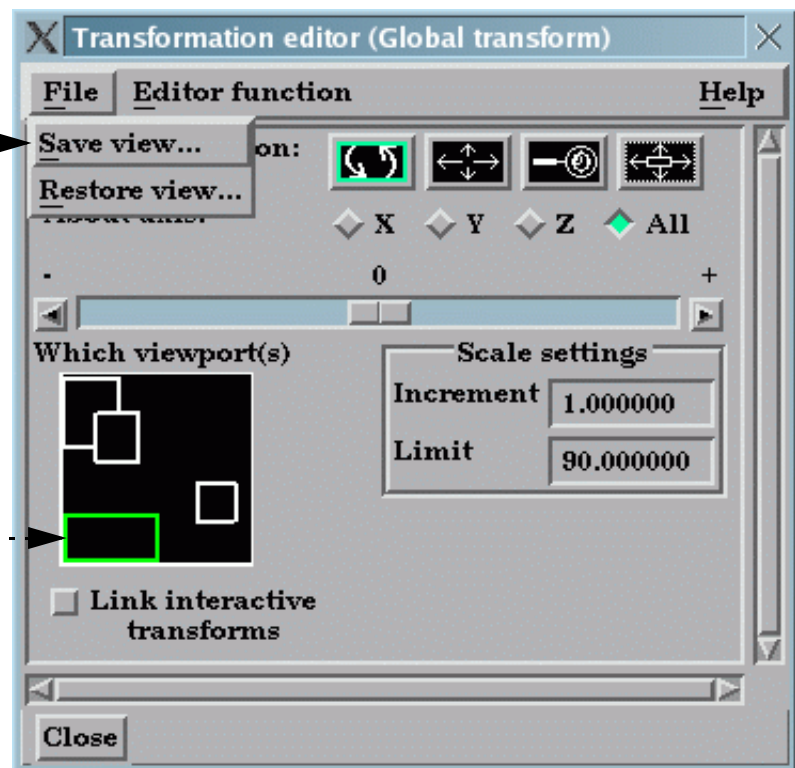

EnSight provides a maximum of 16 viewports: the main viewport (which you cannot change) and 15 additional viewports. When EnSight saves one or more viewports, it also includes the viewport number (which is equal to the creation order) as a tag. When you request that one or more viewports be restored, EnSight looks in the saved file and searches for tag numbers corresponding to the currently selected viewports. If it finds a match, it restores that viewport. If there is no match for a selected viewport, it is left unchanged.

Restoring Viewing Parameters

Click **Transf...** in the Transformations Control area to open the Transformations dialog.

1. Select the viewports you want to restore. As shown above, click within a viewport to select it. Hold down the control key as you click to select additional viewports.
2. Select **Restore View...** from the File menu. Select a file name in the file browser and click OK.

What is Saved

Only global and local (frame) transformations are stored in a view parameters file. No information is stored for viewport attributes, look-from/look-at points, or Z clipping.

Other Notes

By default, the F5, F6, or F7 buttons restore a standard right, top, or front view (respectively) of the selected viewport. However, by holding down the Control key while pressing one of these keys, the current view will be saved to that key. Subsequent pressing of that key will restore the saved view. Only Global transforms are saved / restored by these operations, *not* Frame transforms.

SEE ALSO

[How to Define and Change Viewports](#), [How to Create and Manipulate Frames](#).

User Manual: [Save/Restore View](#)



INTRODUCTION

By default, all parts are assigned to the same frame of reference. You can, however, create additional coordinate frames and assign parts to them. These frames (and the parts assigned to them) can be manipulated (rotated, translated, scaled) independently of other frames. Some examples of frame usage:

1. You wish to create a **copy** of a part and display a different variable on the copy. When you create the copy, a new frame is automatically created and the copy is assigned to it. The new frame can be translated away from the original to visualize both variables simultaneously.
2. You wish to create an animation of parts moving independently (e.g. for an exploding view or to “open” a closed object with a “hinged door”). Each dynamic part is assigned to a new frame. During **keyframe animation**, the frames are manipulated independently to achieve the desired motion.
3. You have a dataset with **rotational periodicity** but the symmetry axis is not aligned with a major axis. A new frame is created and positioned such that one of its axes is aligned with the symmetry axis.
4. You have a dataset that makes correct positioning of EnSight tools difficult, e.g. a duct not aligned with a major axis. Create a new frame and align one of the axes with the duct. Since tool positions are always specified with respect to the current frame, you can now use the Transformation Editor to accurately position tools along the axis of the duct.

In addition to position and orientation, frames have a number of display attributes such as visibility, line width, and color. You can also specify the length of each axis separately and display a series of evenly spaced labels to use as a 3D measuring tool.

Frames are a powerful but complex feature of EnSight. Understanding the basics of frames is essential for proper use. This article is divided into the following sections:

[Introduction](#)

[Create a New Frame](#)

[Select Frames](#)

[Assign Parts to Frames](#)

[Move and Rotate Frames](#)

[Reset Frame Transform](#)

[Set Frame Attributes](#)

[Determine What Frame a Part is Assigned To](#)

[Delete Frames](#)



BASIC OPERATION

Introduction

On startup, EnSight creates a default frame – frame 0 – located at 0,0,0 of the right-handed “world” or model coordinate system and aligned with the X, Y, Z axes. All parts (model and newly created) are assigned to frame 0 initially. Frame 0 is special in that it *cannot* be repositioned or deleted.

Note: Frame mode is reserved for the expert user. By default, it is not enabled. To enable it, go to Edit->Preferences..., select General User Interface and toggle on Frame Mode Allowed.

Frames are selected either by clicking the frame axis triad (while in Frame mode) in the Graphics Window or by selecting the frame in the “Which Frame” list of the Transformation Editor dialog. Any frame operation (such as setting attributes) acts on the currently selected frames.

The EnSight positioning tools (Cursor, Line, Plane, and Quadric tools) are always positioned *with respect to the currently selected frame*. If more than one frame is selected, frame 0 is the reference frame for tools. If you have tools visible, you will notice them changing position as the selected frame is changed.

EnSight implements computational periodicity (such as rotational symmetry) as an attribute of frames. If a frame has symmetry enabled, all parts assigned to the frame will be duplicated as specified by the particular type of symmetry.

All frame axis triads are visible when in Frame mode. The axis triad consists of three lines representing the X, Y, and Z orientation vectors plus labels. Selected frames are colored with the default highlight color (typically green). If the frame is visible (meaning it will be displayed in all modes) the frame axes are drawn with solid lines. Otherwise, dashed lines are used.

EnSight does not support hierarchical frames: you cannot assign a frame to another frame to implement nested transformations. All frames are embedded in the same world coordinate system (*i.e.* frame 0).

Create a New Frame

In general, you have to explicitly create new frames. However, EnSight will automatically create a new frame each time you create a copy of a part and assign the copy to the frame.

To create a frame:

1. Click Frame in the Mode Selection area to enter Frame mode.

(Note: If Frame does not appear as an available mode, first go to Edit->Preferences..., select General User Interface and toggle on Frame Mode Allowed.)

The initial position of a new frame can either be set to 0,0,0 or automatically centered on a set of parts.

2. If desired, select one or more parts in the Main Parts list – the new frame will be centered on the selected parts.

3. Click the New Frame icon to create the frame.



The new frame also becomes the currently selected frame.



Select Frames

There are two ways to select frames. You can click on the frame axis triad in the Graphics Window or select frames in the "Which Frame" list in the Transformation Editor dialog. Selected frames are colored with the default highlight color (typically green).

To select frames in the Graphics Window:

1. Click **Frame** in the **Mode Selection** area to enter **Frame mode**.

(Note: If **Frame** does not appear as an available mode, first go to **Edit->Preferences...**, select **General User Interface** and toggle on **Frame Mode Allowed**.)

2. Position the mouse pointer over the frame axis triad (the lines – not the XYZ labels) and click the left mouse button.

You can extend a selection of frames by holding down the **Control** key as you click on frames.

You can select all frames by clicking: 

To select frames using the Transformation Editor dialog:

1. Click the **Transf...** icon in the **Transformation Control** area to open the **Transformation Editor** dialog.

2. Select **Frame > Transform** from the **Editor Function** menu. Note that this puts **EnSight** into **Frame mode**.

3. Select the desired frames in the **Which Frame** list.

You can use standard Motif list selection techniques, such as shift-click to extend a selection or control-click to de-select an item.

The **Which Frame** list is also displayed if the **Editor Function** menu is set to one of the **Tool modes** (e.g. **Tools > Cursor**).

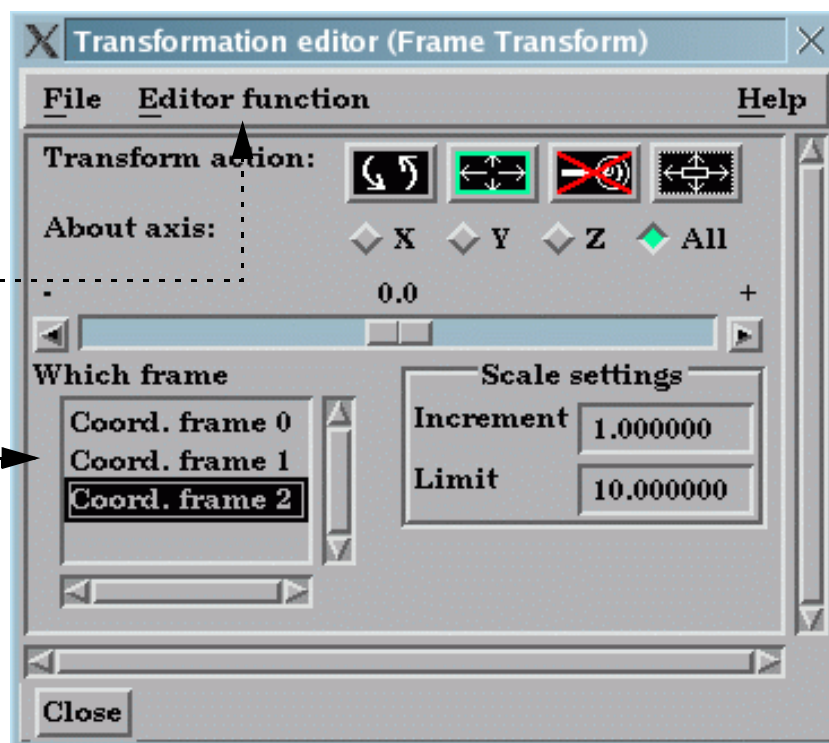

Assign Parts to Frames

To assign a part to a frame:

1. Click **Frame** in the **Mode Selection** area to enter **Frame mode**.

(Note: If **Frame** does not appear as an available mode, first go to **Edit->Preferences...**, select **General User Interface** and toggle on **Frame Mode Allowed**.)

2. Select the desired part(s) in the **Main Parts** list.

3. Select the desired frame (as described above).

4. Click the **Part Assignment** icon to assign the part(s) to the frame. 

A message is printed to the **Status History** area confirming the assignment.



Move and Rotate Frames

You transform a frame (and all parts assigned to it) when you perform any transformation while in *Frame Transform mode*. Frame Transform mode is set automatically when you enter Frame Mode. You can also set it explicitly from the Editor Function menu in the Transformation Editor dialog.

To transform in Frame Transform mode:

1. Click **Frame** in the **Mode Selection** area to enter **Frame mode**.

(Note: If Frame does not appear as an available mode, first go to **Edit->Preferences...**, select **General User Interface** and toggle on **Frame Mode Allowed**.)

2. Toggle the **Transform/Definition** button to be.....

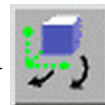

3. Select the desired frame(s) (as described above).

4. Perform the desired transformation either interactively (using the Transformations Control icons and the mouse in the Graphics Window) or via the Transformation Editor dialog. See [How To Rotate, Zoom, Translate, and Scale](#) for more information.

Frame transforms are implemented as a transformation applied with respect to the frame's position and orientation. At times you will need to modify the position and orientation of the frame independent of the parts assigned to it. This is done while in *Frame Definition mode*. You enter Frame Definition mode either explicitly from the mode menu in the Transformation Editor dialog (Editor Function > Frame > Definition), or via the Transform/Definition pull-down icon while in Frame Mode.

Important! You cannot change the frame definition if you have performed any frame transformations (if you attempt to do so, a dialog will remind you). Any frame definition must be applied prior to a frame transformation. If you have already made frame transforms you can clear them by returning to frame transform mode and using the Reset Tools and Viewports dialog (click Reset... to open).

To transform the Frame Definition:

1. Click **Frame** in the **Mode Selection** area to enter **Frame mode**.

2. Toggle the **Transform/Definition** button to be.....



3. Select the desired frame(s) (as described above).

4. Perform the desired transformation. This can be done either interactively (with the mouse in the Graphics Window) or via the Transformation Editor dialog. To translate the frame interactively, move the mouse pointer into the Graphics Window and click and drag the left mouse button. To rotate the frame interactively, click and hold the left mouse button on one of the frame axes and drag the mouse. Clicking on the X axis will rotate the frame about its Y axis. Clicking on the Y axis will rotate the frame about its X axis. Clicking the Z axis will rotate about both X and Y. Use the Transformation Editor dialog to rotate about the Z axis only.



You can also edit the frame's definition explicitly using the Transformation Editor dialog:

1. Click **Frame** in the **Mode Selection** area to enter **Frame** mode.

(Note: If **Frame** does not appear as an available mode, first go to **Edit->Preferences...**, select **General User Interface** and toggle on **Frame Mode Allowed**.)

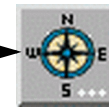

2. Click the **Frame Location Attributes** icon.....

This opens the Transformation Editor dialog in Frame Definition mode.

3. Select the desired frame(s).

4. If desired, enter new value(s) in the **XYZ** fields to change the frame's origin (remember to press return).

5. If desired, enter new value(s) for the orientation vectors (remember to press return).

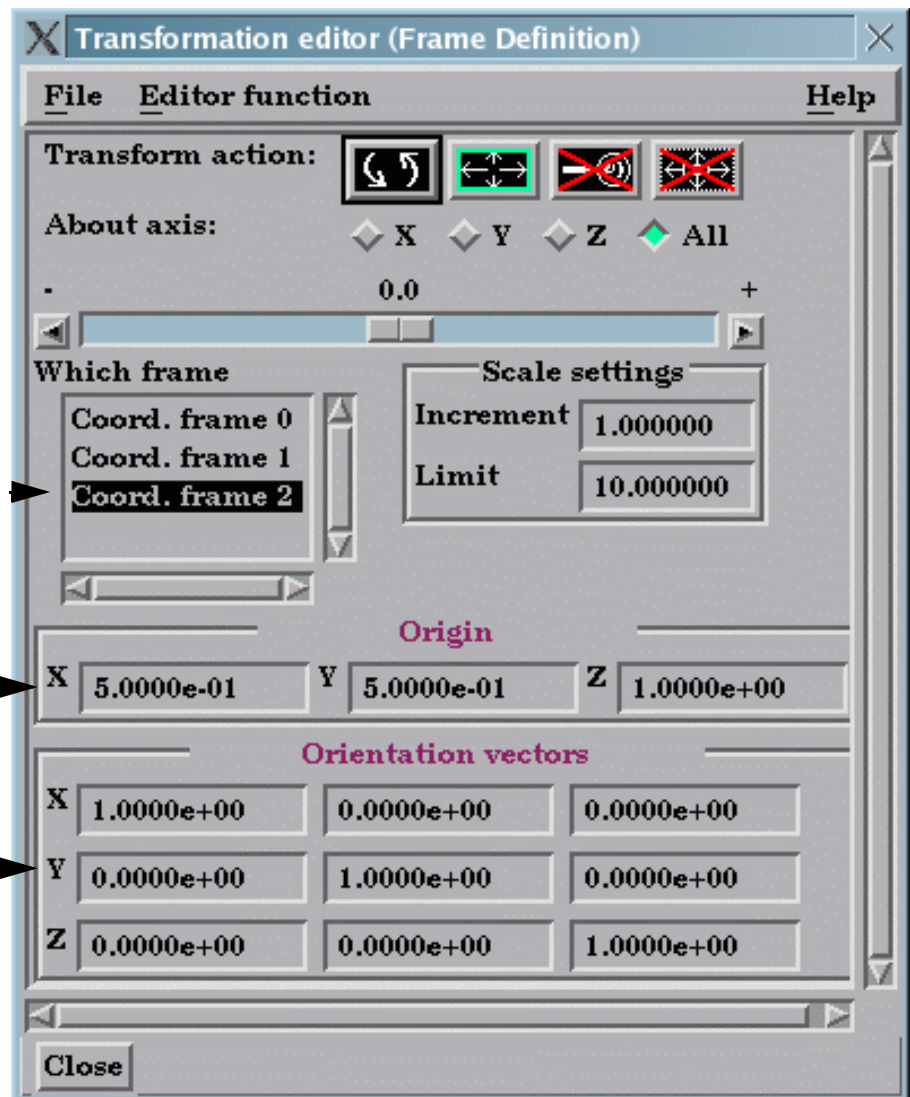

Note that the orientation vectors are normalized afresh when you press return.

Reset Frame Transform

The frame transform can be reset back to the default position and orientation by using the Reset Tools and Viewports dialog. To clear the frame transform:

1. Click **Frame** in the **Mode Selection** area to enter **Frame** mode.

2. Make sure the **Transform/Definition** button is set to **transform**.....



3. Select the desired frame(s) (as described above).

4. Click the **Reset...** button in the **Transformation Control** area to open the **Reset Tools and Viewports** dialog.

5. In the **Reset Tools and Viewports** dialog, click the desired button:

Reset By Selected Transform Only: clear only the transformation component currently selected (e.g. rotate or translate) in the Transformation Control area

Reset Rotate/Translate/Scale: clear all transformation components

See [How To Reset Tools and Viewports](#) for more information.



Set Frame Attributes

Frames can be displayed with a variety of attributes:

1. Click **Frame** in the **Mode Selection** area to enter **Frame mode**. (If needed, first enable **Frame Mode** under **Edit->Preferences...**, **General User Interface**.)
2. Select the desired frame(s) (as described above).
3. Set the desired attribute as described below:

Click the **Frame Visibility Toggle** to toggle display of the axis triad of selected frames on or off (when not in **Frame Mode**).

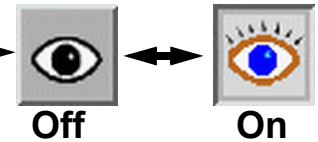

Click (opens the **Color Selector**) to set the color for the axis triad of selected frames.



Click the **Frame Line Width** pull-down to set the line width for the axis triad of selected frames.

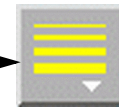

Click the **Axis Triad Attributes** icon to set axis attributes (described below):

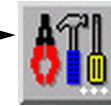

To adjust the length of the frame axes, enter new values in the **X**, **Y**, and **Z Length** fields and press return.

To display a series of evenly spaced labels along an axis (showing distance from the axis origin), toggle on the applicable **Label** button, enter the desired number of labels in the **# of** field, and press return.

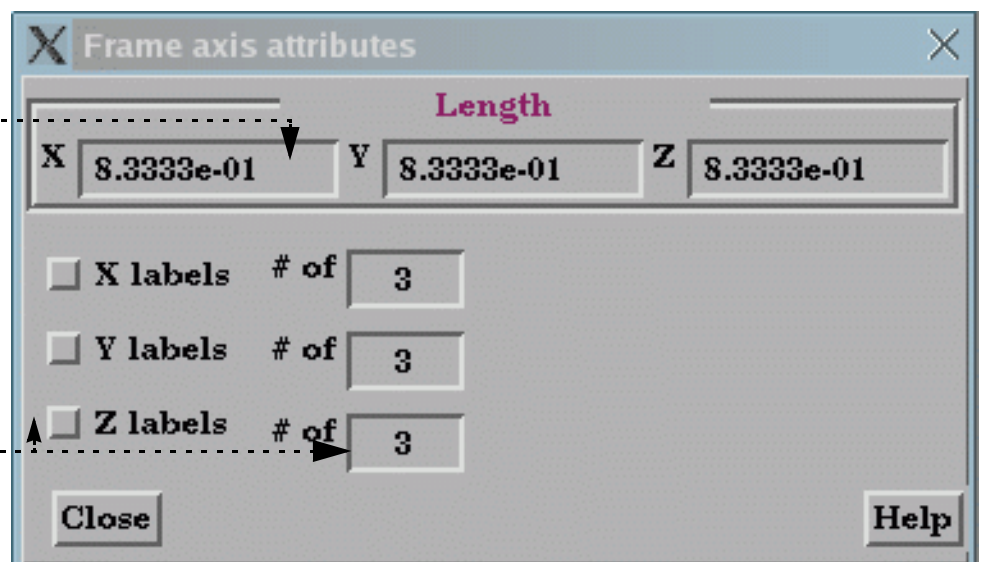



Determine What Frame a Part is Assigned To

You can determine what frame a part is assigned to (and change it) by opening the Feature Detail Editor for the part:

1. Open the Feature Detail Editor for the part type (Edit > Part Feature Detail Editors >) or double click on the appropriate Feature Icon.
2. Select the desired part in the parts list at the top of the Feature Detail Editor.

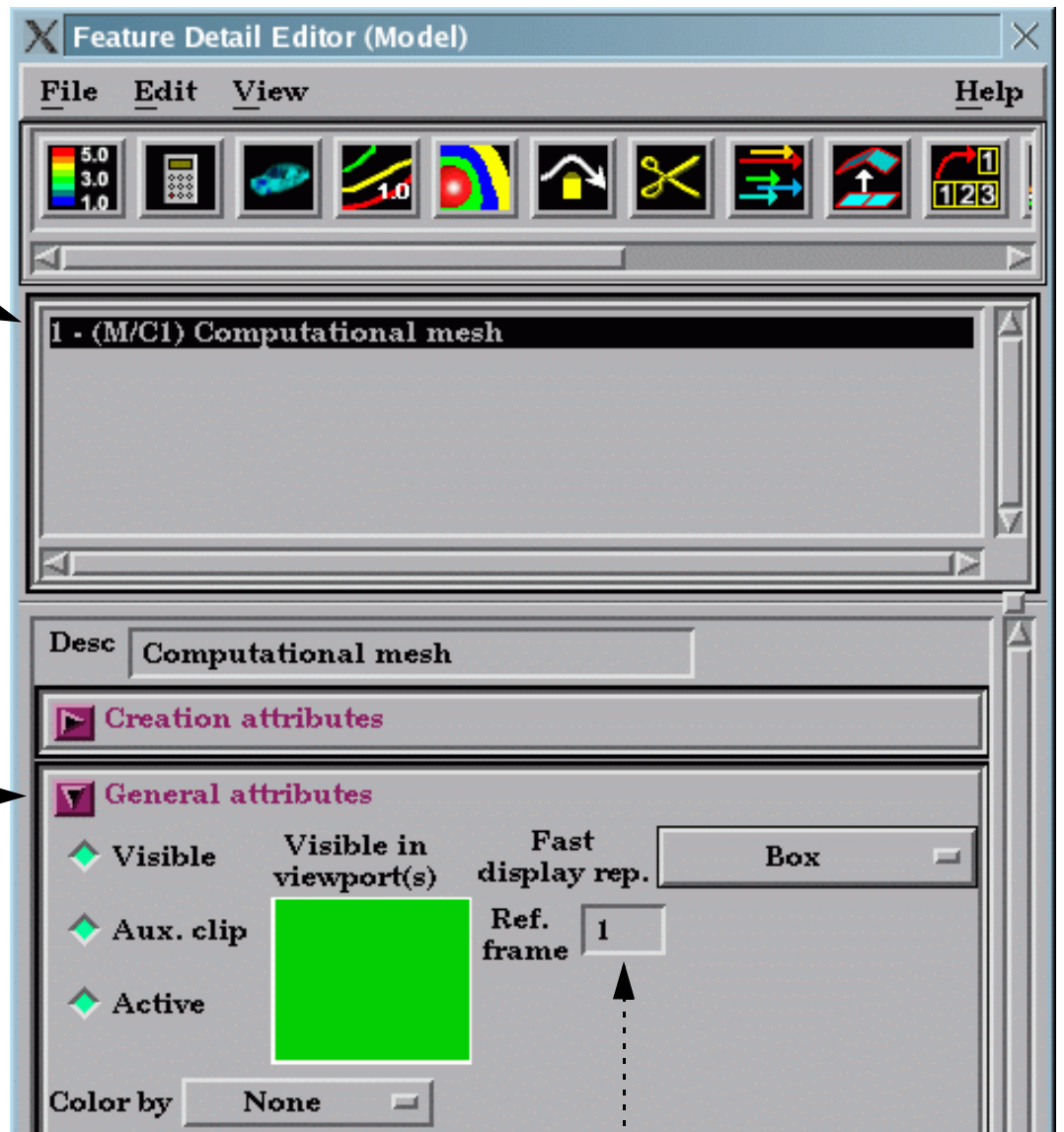

3. Open the General Attributes section.

The part's current frame number is shown in the Ref. Frame field. You can reassign a part to a different frame by entering a new value and pressing return.

Delete Frames

Selected frames can be deleted. Note that a frame cannot be deleted if any parts are currently assigned to it. All parts assigned to the frame must be assigned to other frames prior to deletion.

1. Click Frame in the Mode Selection area to enter Frame mode.
2. Select the desired frame(s) (as described above).
3. Click the Delete icon.



SEE ALSO

[How To Set Symmetry](#), [How To Rotate, Zoom, Translate, and Scale](#), [How To Reset Tools and Viewports](#)

User Manual: [Frame Mode](#)

INTRODUCTION

EnSight provides support for complex transformations of various entities (e.g. the scene, tools, frames). It is often necessary to clear all or part of the transformation associated with an entity; the Reset Tools and Viewports dialog provides this capability.

BASIC OPERATION

To clear global transformations or tool positions:

1. Click **Part** in the **Mode Selection** area (to be sure that EnSight is in **Global Transform** rather than **Frame** transform).

2. Click the **Reset...** button in the **Transformation Control** area to open the **Reset Tools and Viewports** dialog.



3. Perform the desired operation as described below.

4. Click **Close**.

Transformations will only be reset for the current viewport(s). Click in a viewport to select it. Control-click to extend the selection or de-select a selected item.

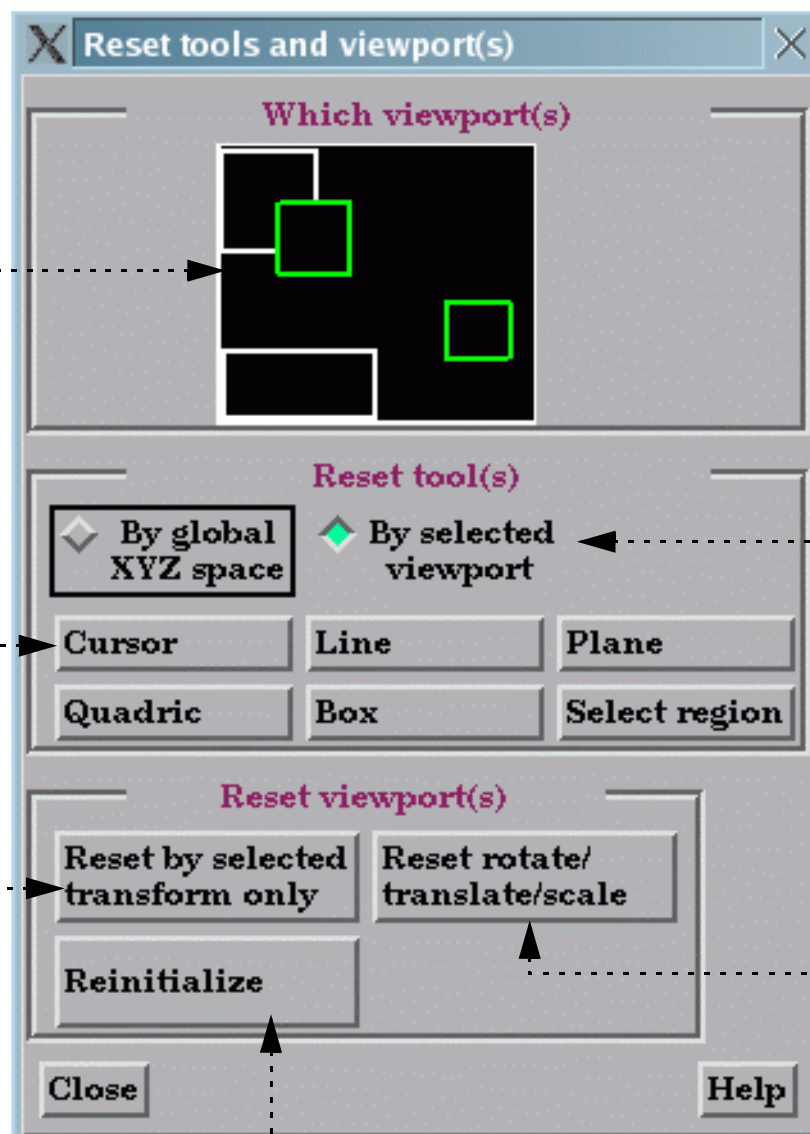

Click the applicable button to reset the corresponding tool.

Click to clear *only* the transformation component currently selected in the Transformation Control area (e.g. Rotate or Translate).

Click to clear all transformations as well as reset the camera look-from/look-at points so that all currently visible parts are centered in the selected viewport(s).

Toggle selects whether tool is reset based on the global XYZ space or reset based only on the selected viewport.

Click to clear all transformations in the selected viewport(s). Note that zoom is not a scene transformation and is not cleared. Zoom is implemented by moving the look-from point (the camera position). To clear zoom, click Reinitialize.

ADVANCED USAGE

The Reset Tools and Viewports dialog is also used to clear Frame transformations. See [How To Create and Manipulate Frames](#) for more information on frames and frame transforms.

To clear frame transformations:

1. Click **Frame** in the **Mode Selection** area to enter **Frame mode**. (If needed, first enable Frame mode under **Edit->Preferences... General User Interface**.)

2. Make sure the **Transform/Definition** button is in the **transform state**

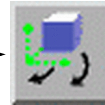

3. **Select** the desired frame(s).



4. Click the **Reset...** button in the **Transformation Control** area to open the **Reset Tools and Viewports** dialog.

5. Perform the desired operation as described below.

6. Click **Close**.

Frame transformations will only be reset for the current viewport(s). Click in a viewport to select it. Control-click to extend the selection or de-select a selected item.

Click to clear *only* the frame transformation component currently selected in the Transformation Control area (e.g. Rotate or Translate) for the selected frame(s) in the selected viewport(s).

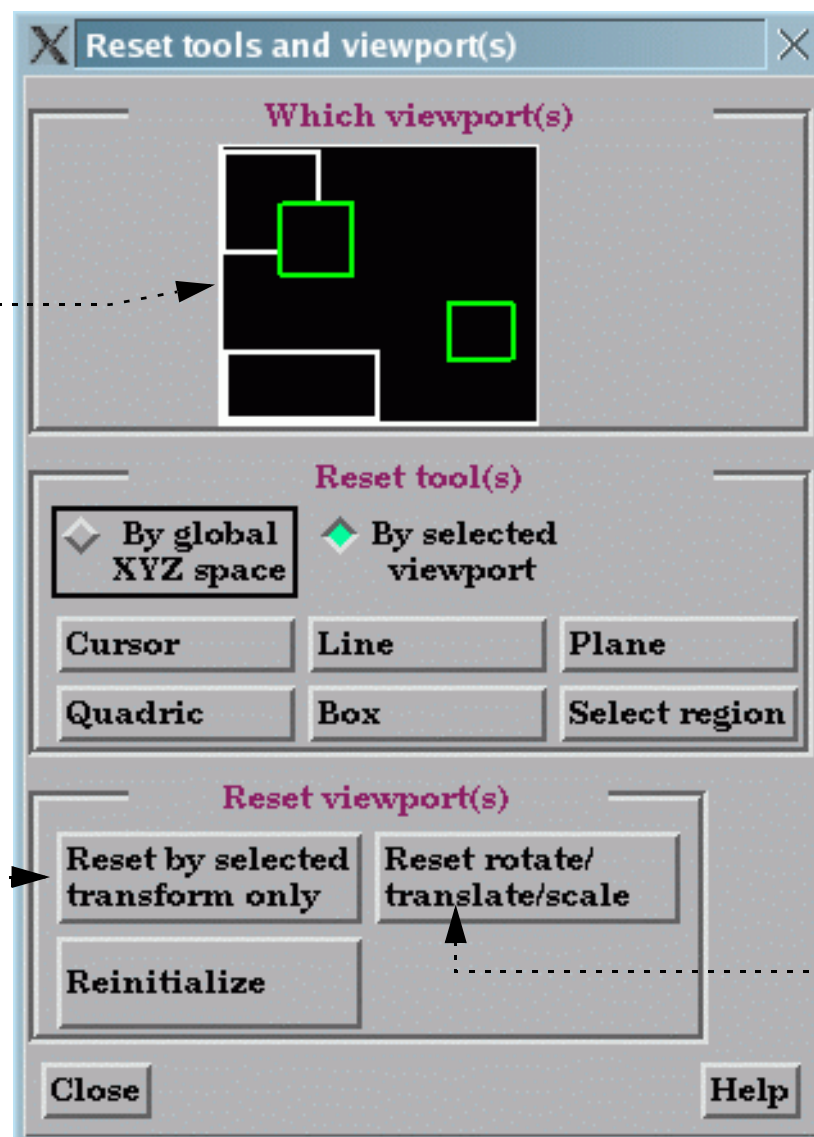

Click to clear all frame transformations for the selected frame(s) in the selected viewport(s).

SEE ALSO

[How To Rotate, Zoom, Translate, Scale](#), [How To Define and Change Viewports](#), [How To Create and Manipulate Frames](#)

Use the Color Selector

INTRODUCTION

Several operations in EnSight require that you select a color. The Color Selector dialog is used throughout the user interface to provide a powerful and easy-to-use color selection mechanism.

BASIC OPERATION

The selector operates using one of two basic color models: RGB or HSV. The RGB color model specifies color by the percentage of red, green, and blue and closely mimics the way computers deal with color. The HSV color model specifies colors as percentages of *hue* (the actual color with red equal to both 0.0 and 1.0, green equal to 0.33, and blue equal to 0.66), *saturation* (the “amount” of color, where 0.0 is white and 1.0 is full), and the *value* (the brightness, where 0.0 is black and 1.0 is full). The HSV model is often more intuitive for mixing custom colors. Although HSV is the default, you can switch to RGB by clicking the RGB toggle button.

The dialog provides four basic methods of selecting colors:

1. By picking one of the predefined colors from the grid of color cells.

2. By grabbing the marker in the color cube and moving it with the mouse.

Color square always displays the current color selection.

3. By entering values for HSV (or RGB, depending on mode) directly in the fields and pressing return.

4. By grabbing and moving the sliders associated with each color component.

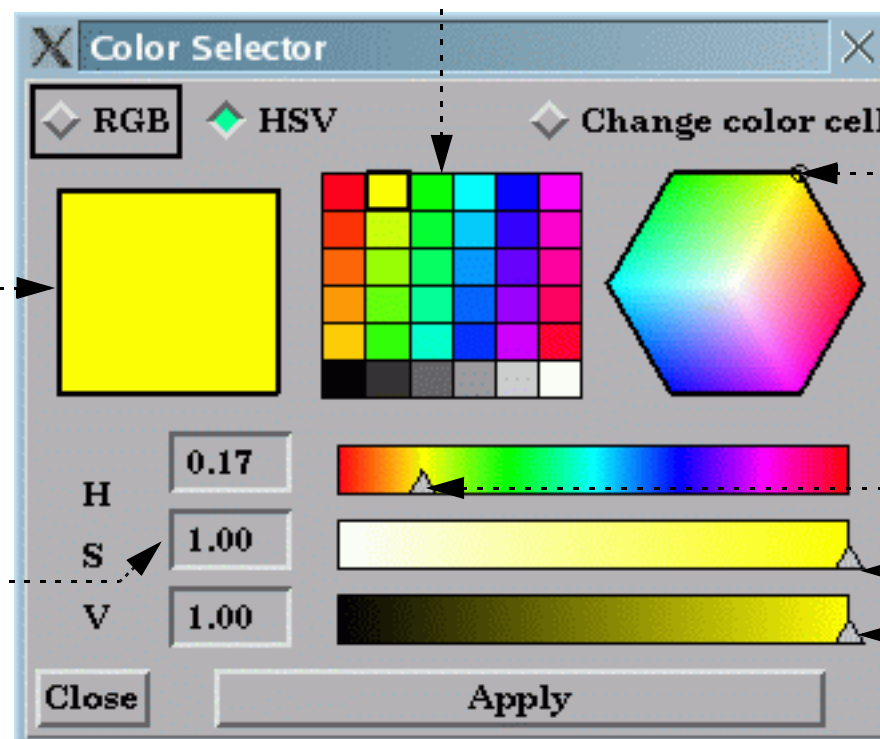

When you have selected a color, click the Apply button to have the selected color applied to the object being edited (e.g. part, color map level, text, etc.).

Specify Custom Colors

If you have colors that you use frequently that are not represented in the color grid, you can save them by replacing selected cells. Your custom colors are automatically saved for future sessions. To set custom colors:

1. Select the desired color using any of the methods described above.
2. Toggle on Change Color Cell.
3. Click in the color cell you wish to replace.
4. Continue to select colors and replace cells.
5. Toggle off Change Color Cell when done.

The color information is saved in `~/ensight8/ensight.colpal.default`.

SEE ALSO

User Manual: [Color Selector](#)



INTRODUCTION

EnSight supports active stereo display on workstations with quad-buffered OpenGL stereo capability, in addition to passive (polarized) stereo support for detached displays (see [How To Setup Parallel Rendering](#)). Active stereo works by rapidly displaying alternating left and right eye views on the screen. An emitter (which sits on top of your display monitor) sends an infrared signal to special glasses worn by the viewer(s). The glasses contain liquid crystal shutters that alternately open and close the left and right eye lenses in response to the signal from the emitter in sync with the monitor display. The update frequency is such that the viewer effectively fuses the left and right views into a single stereo image.

Stereo is useful for viewing any type of visually complex geometry. It is especially helpful for visualizing amorphous objects such as animating particle traces, trace ribbons, or discrete particles. It has also been noted that management and customers are typically quite impressed by stereo display.

See the “See Also” section below for information on purchasing NuVision stereo glasses through CEI.

BASIC OPERATION

In EnSight, stereo display is enabled by pressing the F12 key on your keyboard. Pressing the F12 key again will return to normal display. The stereo separation angle can be controlled by pressing the F10 and F11 keys. F10 decreases the angle and F11 increases the angle. When EnSight is configured to use a detached display (see [How To Setup Parallel Rendering](#)), these commands affect only the detached display. The GUI window remains monoscopic.

Configuring your display

On most platforms the display is not initialized by default in a mode which enables stereo viewing. In general quad-buffered stereo requires a refresh rate of 96Hz or higher. On some monitors it may be necessary to decrease the display resolution in order to accommodate this higher refresh rate. Check your monitor documentation before attempting to change the refresh rate.

For Unix platforms there is a utility distributed with EnSight which can be used to determine if your display has stereo capability. Run ‘glx_info’ and look for X visuals with a ‘y’ in the column ‘stro’. If none exist, then the current display parameters do not allow for stereo viewing.

Below are example instructions for various platform configurations which have been tested and confirmed to work with EnSight. When in doubt, refer to your system documentation for OpenGL as well as the X server (Unix) or video adapter device driver (Windows).

Compaq Tru64 Unix

1. Edit the file `/usr/var/X11/Xserver.conf`

Find the section that looks similar to:

```
args <
! PowerStorm 300/350 Server args start
    -pn -su -bs -nice -2
! PowerStorm 300/350 Server args end
    -pn
>
```

Modify to something like:

```
args <
! PowerStorm 300/350 Server args start
    -pn -su -bs -nice -2 -screen 1280x992 -vsync 100
! PowerStorm 300/350 Server args end
    -pn
>
```

Restart the Xserver with `/usr/sbin/xsetup`

2. Connect an appropriate emitter. The NuVision emitter with a 3-pin to 5-pin converted has been tested. CrystalEyes



users should be able to use an 'ESGI' emitter with a 5-pin cable.

HP-UX 10.2 - 11.0

1. Configure the display settings using:

```
/opt/graphics/common/bin/setmon
```

Select a setting which includes "Stereo in a Window"

2. Connect a 3-pin emitter to the graphic card. The NuVision emitter works fine. For CrystalEyes a converter cable may be needed.

IBM AIX 4.3

1. First, make sure that the graphics card is properly configured for OpenGL and stereo display. See the file `/usr/lpp/X11/README` for directions on configuring the X server. You may need to edit the file `/usr/lpp/X11/defaults/xserverrc` to add a "-stereo" argument similar to:

```
#-----
# Load GLX extension to the X server for OpenGL
#-----
if [ -f /usr/lpp/OpenGL/bin/loadGL -a \
    -f /usr/lpp/X11/bin/loadAbx -a \
    -f /usr/lpp/X11/bin/loadDBE ] ; then
    EXTENSIONS="$EXTENSIONS -x abx -x dbe -x GLX -stereo"
fi
```

2. Next you need to set the refresh rate to a stereo-capable setting. Stereo settings are usually 96+Hz vertical refresh. Use the 'smit' tool to see which settings you can use. When running smit, select:

Devices->Graphic Displays->Select the Display Resolution...

You will be prompted to select your graphics adapter. After selecting your graphics adapter you will see the current setting, and you can now query for the available settings. Hopefully you will find something at 96+Hz. If not, you may have a monitor which cannot support such high refresh. Connect a new monitor and reboot the machine, run smit again. Note that many monitors can only handle high refresh at lower resolution (i.e. 1024x768 at 96Hz or 120Hz).

3. The last step is to hook up a stereo emitter to sync with the glasses. We have successfully used the NuVision emitter with built-in 3-pin connector. The CrystalEyes EPRO emitter with external power and 3-pin to BNC cable should work as well.

SGI Irix 6.5

1. Configure the video resolution/refresh rate for stereo. On an Infinite Reality pipe this may be done with something like:

```
/usr/gfx/ircombine -destination eeprom -source file \
    /usr/gfx/ucode/KONA/dg4/cmb/1024x768_120s.cmb -target :0.0
```

On other platforms the `/usr/gfx/setmon` command can be used to select the correct mode. An example may be:

```
/usr/gfx/setmon 1024x768_96s
```

See the man page for platform specific information and the locations of the configuration files. You may get a message telling you that the format is not available, however in some cases all that is needed is a reboot in order to switch the resolution.

2. Hook up your stereo emitter. The CrystalEyes ESGI emitter works with the SGI, and there is a 3-pin to 9-pin cable to use the NuVision emitter on the SGI.

Sun Solaris 8

1. Configure the video resolution/refresh rate for stereo. On an Expert3D Card this is done with a command similar to:

```
fbconfig -dev /dev/fbs/ifb0 -res stereo
```

The fbconfig utility is a wrapper tool that calls `afbconfig`/`ffbconfig` depending on the type of graphics adapter.

2. Hook up a stereo emitter. The Expert3D uses a 7-pin cable.





Linux

A few OpenGL drivers are known to support stereo OpenGL under Linux, including the HP fx-5/fx-10 and the ATI FireGL2/FireGL4. Documentation is included with the drivers, which may be downloaded from the card vendors web sites.

MS Windows

Configuration of stereo under Microsoft Windows is dependent upon the graphics card driver which is installed. Right-click on the background and choose "Properties" to open to Display Properties dialog. Look for a tab which such as "OpenGL Properties" or "Advanced" and search for a stereo option. In many cases there is a toggle button for enabling stereo display. You will usually need to restart the machine in order for changes to take effect. If stereo still does not work, try changing the display resolution, as stereo may not be available at higher resolutions.

SEE ALSO

Most SGI hardware is "stereo ready" meaning that you need no additional hardware (other than glasses and the emitter). However, check with your local SGI technical representative to be sure. The O2, in particular is *not* stereo ready and additional hardware must be purchased.

In the U.S., NuVision hardware (glasses and emitters) can be purchased through CEI. Contact Sales and Marketing for pricing and availability:

CEI, Inc.
919-363-0883
919-363-0833 FAX
ensight@ceintl.com

Outside the U.S., contact your local EnSight distributor.



Pick Center of Transformation

INTRODUCTION

EnSight allows you to pick where you would like the center of transformation to be for the model.

BASIC OPERATION

1. Click the **Pick** button in the global area above the graphics window on the desktop.

2. Toggle on **Pick Center of Transformation**.

3. Position the mouse cursor on your model at the desired location for the center of transformation.

4. Press the “p-key” (or whatever mouse button you have set for “Selected Pick Action” in **Edit > Preferences > Mouse and Keyboard**).

Your model will now rotate about the position on the model that you just picked.

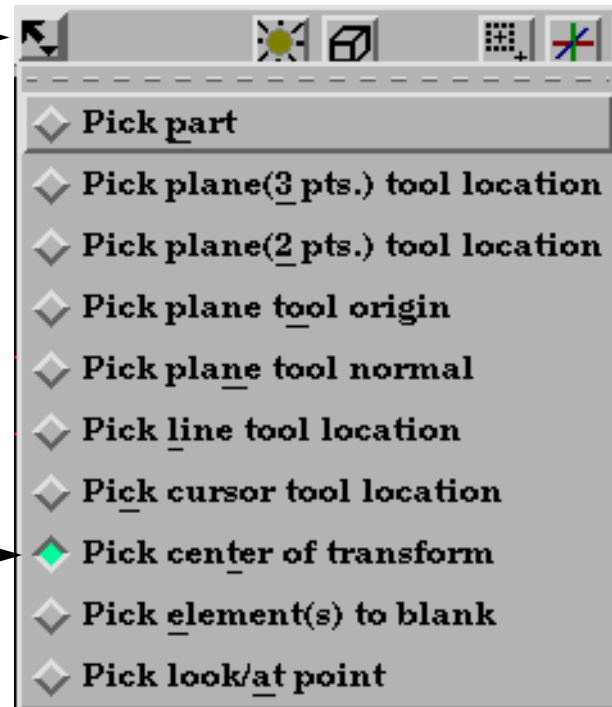

You can also set or change the exact location of the center of transform by using the Transformation Editor.

1. Click the “Transf...” button on the desktop below the graphics screen.

2. Under “Editor Function”, select “Center of Transform”.

3. Set or modify the x,y,z coordinate location of the center of transform in the dialog which comes up.

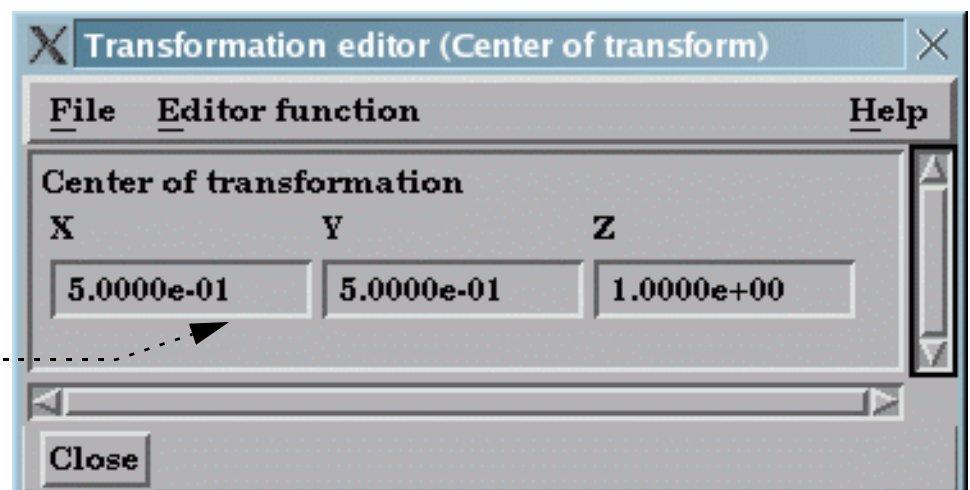

SEE ALSO

User Manual: [Center Of Transform](#)

Set Model Axis/Extent Bounds

INTRODUCTION

EnSight provides model axes and extent bounds to help in orienting your model. These features are toggled on/off via the quick access area on the desktop.....

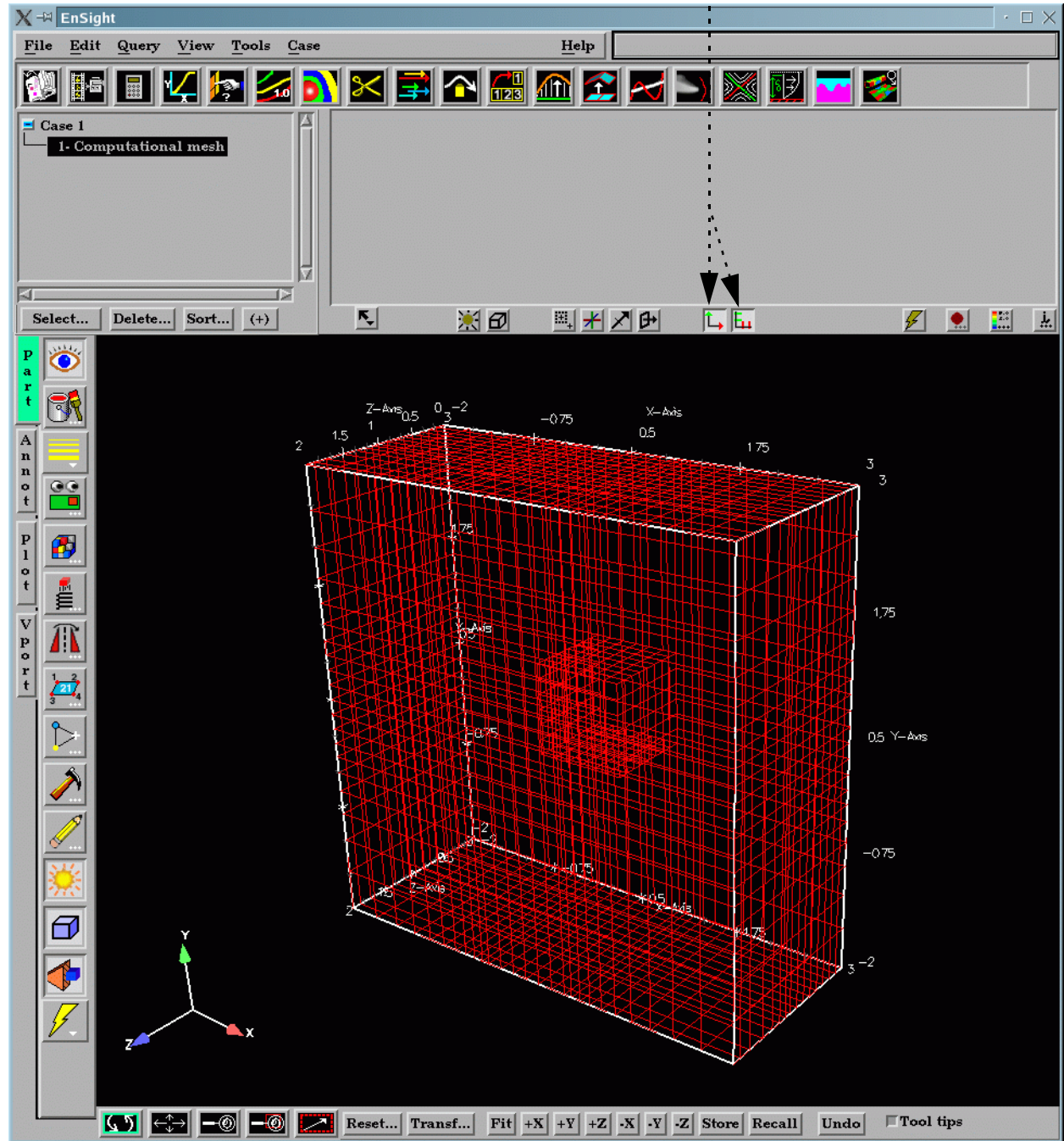

BASIC OPERATION

Model Directional Triad

The model axes help maintain awareness of the principal directions of the reference frame of the model. This is especially helpful during model transformations.



Click the Axis toggle to display the model directional triad.



Model Extent Bounds

The model extent bounds also help maintain dimensional information pertaining to the extents of the model.



Click the Bounds toggle to display the model extents ...

To control the various attributes associated with the model extents:

1. Select the Viewport Mode icon.
2. Select the Model Extent Bounds icon, which opens the Viewport 2D/3D Grid attributes dialog.
3. Modify the various general and/or axes attributes as desired.

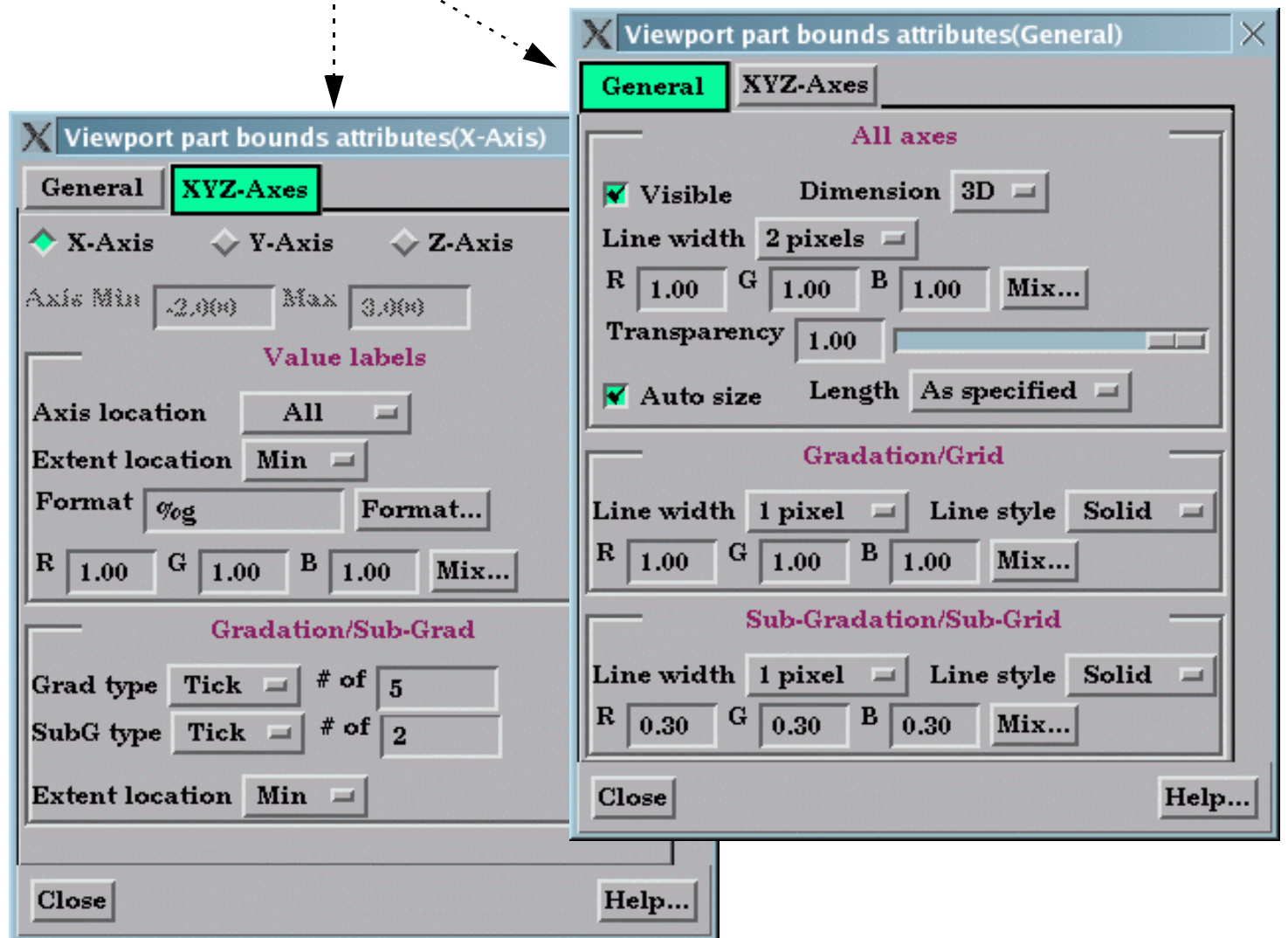
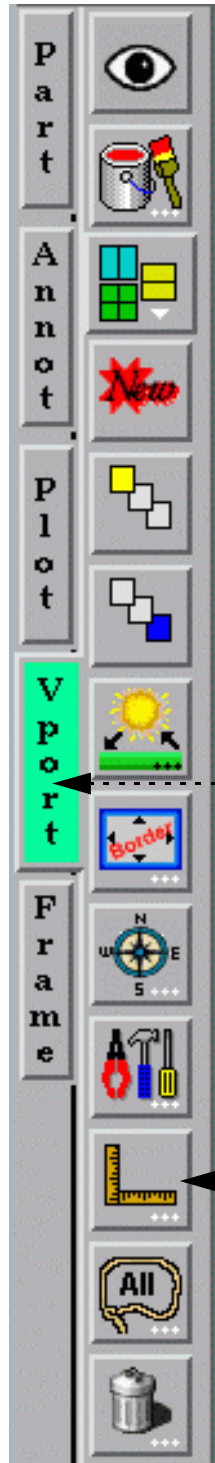

SEE ALSO

User Manual: [Part Bounds Attributes](#)



Do Viewport Tracking

INTRODUCTION

EnSight provides the capability to “track” a particular location on the model parts displayed in a viewport. Tracking means that the viewport will be caused to center on the chosen location as time is changed. This is particularly useful for models with changing geometry or applied displacements - allowing one to stay focused on the moving bodies during an animation.

BASIC OPERATION

Viewports can be displayed with a variety of attributes:

The image shows a vertical toolbar on the left with sections: Part, Annot, Plot, VPort (highlighted), and Frame. The 'VPort' section contains icons for various viewport settings. To the right, a dialog box titled 'Viewport special attributes' is open, showing options for View dimension (3D), Perspective, Shaded, and Hidden line (all checked). It also has a 'Track' dropdown set to 'Off', and input fields for 'Part ID' (containing '1') and 'Node ID'. Below the dialog, a list of tracking options is shown: Off, Node number, Part centroid, Part xmin, Part xmax, Part ymin, Part ymax, Part zmin, and Part zmax.

1. Click VPort in the Mode Selection area to enter Viewport mode.
2. Select the desired viewport(s).
3. Click the Viewport Special Attributes icon to open the Viewport Special Attributes dialog.
4. Select the Tracking option desired,
5. And supply the node or part id appropriately.
6. Change time step, load a transient flipbook, or the like and note that the viewport will stay centered on the location chosen.

SEE ALSO

[How To Define and Change Viewports](#)

User Manual: [VPort Mode](#)

INTRODUCTION

EnSight provides a 3D point specification tool called the “Cursor” tool. When visible, the Cursor appears as a 3D cross colored red (X axis), green (Y axis), and blue (Z axis). The Cursor tool is used to supply EnSight with point information, for example to specify the location for a query or the starting point for a particle trace.

BASIC OPERATION

In many cases, the Cursor tool will automatically turn on when performing some function that requires it. You can also turn the tool on and off manually by toggling the Cursor entry in the Tools menu or by clicking the Cursor toggle on the Desktop.

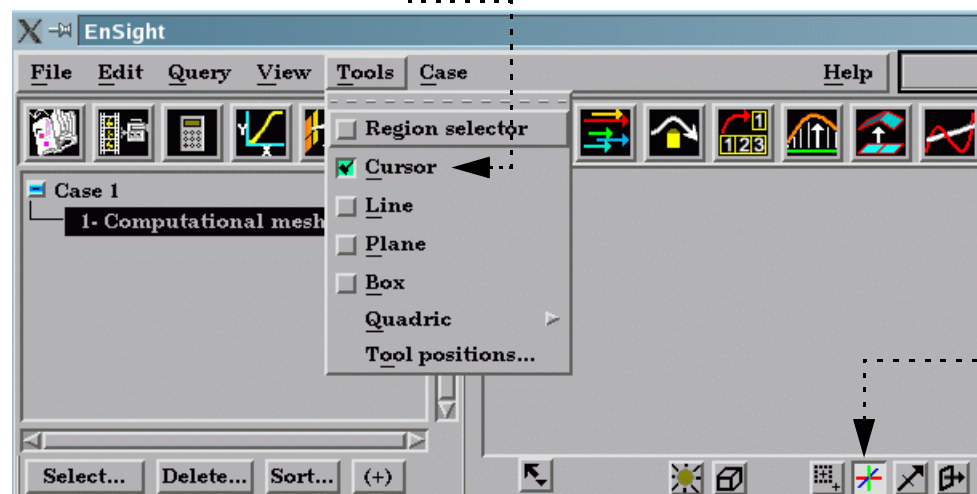

The Cursor tool can be placed in three ways: interactively through direct manipulation with the mouse, by positioning the mouse pointer over a part and pressing the ‘p’ key, or precisely positioned by typing coordinates into a dialog.

To position the Cursor with the mouse:

1. **Place the mouse pointer over the center of the tool.**
Note that the mouse cursor will change when over the center of the cursor tool (if in Part or Frame mode).
2. **Click (and hold) the left mouse button.**
3. **Drag the Cursor to the desired location.**
4. **Release the mouse button.**

(Undo/Redo button at the bottom of screen can be used to undo/redo the tool transformation)

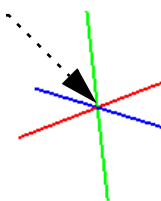

Cursor translation is restricted to the plane perpendicular to your line of sight. If you need to move the cursor in another plane, rotate the model such that the desired translation plane is perpendicular to your new line of sight. (Note that the Cursor may not exactly track the location of the mouse pointer.)

To position the Cursor on a part with the ‘p’ key:

1. **Click the Pick button in the global area above the graphics window on the desktop.**
2. **Select “Pick cursor tool location” from the pop-up menu.**
3. **Place the mouse pointer over the desired location on a part in the graphics window and press the ‘p’ key (or whatever mouse button you have set for the “Selected Pick Action” in Edit > Preferences > Mouse and Keyboard).**

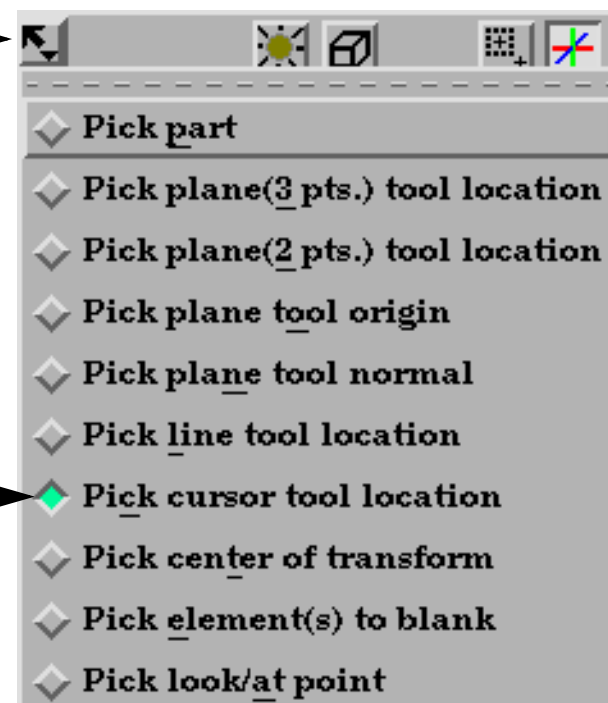



To set the Cursor by specifying coordinates:

1. Open the Transformation Editor dialog by clicking Transf... on the desktop.

2. Select Editor Function > Tools > Cursor.....

3. Enter the desired coordinates into the X, Y, and Z type-ins and hit return.

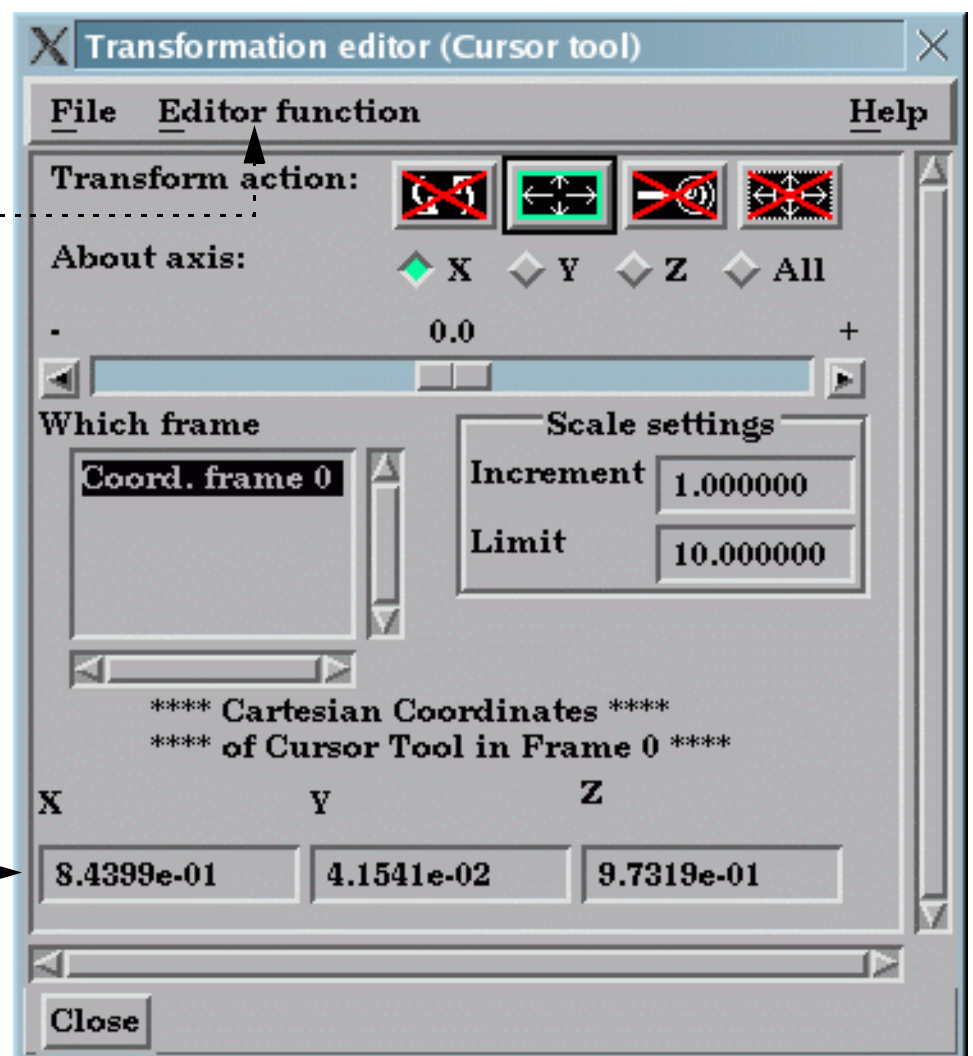

You can also move the Cursor by setting the desired axis of translation in the Axis pop-up and manipulating the slider bar. In this case, the values in the “Scale Settings” section control the sensitivity and limit of the slider action.

Note that you can also use this dialog to view (rather than set) the position of the Cursor since the X,Y,Z numeric values always update to reflect the current location. If you are positioning the Cursor interactively with the mouse, the values will update when the mouse button is released.

ADVANCED USAGE

After a model has been loaded, the initial location of the Cursor is set to the “look-at” point – the geometric center of all visible geometry. The coordinates of the Cursor are specified with respect to the default frame: frame 0. However, if you have created additional **frames**, you can position the Cursor relative to the origin of a different frame. This is accomplished by selecting the desired frame in the “Which Frame” list in the Transformation Editor dialog.

You can easily reset the position of the Cursor tool to the default. See [How To Reset Tools and Viewports](#) for more information.

Positioning a 3D tool with a 2D device (the mouse) can be difficult. Multiple **viewports** are sometimes helpful in positioning tools since you can see the tool simultaneously from multiple vantage points.

SEE ALSO

Other tools: [Line](#), [Plane](#), [Box](#), [Cylinder](#), [Sphere](#), [Cone](#), [Surface of Revolution](#). See the How To article on [Frames](#) for additional information on how frames effect tools.

User Manual: [Tools Menu Functions](#)



Use the Line Tool

INTRODUCTION

EnSight provides a 3D linear specification tool called the “Line” tool. When visible, the Line tool appears as a (typically white) line with a cross at the center point. The Line tool is used to supply EnSight with a linear specification, for example to specify the location for a line clip or a “rake” for a particle trace.

BASIC OPERATION

In many cases, the Line tool will automatically turn on when performing some function that requires it. You can also turn the tool on and off manually by toggling the Line entry in the Tools menu or by clicking the Line toggle on the Desktop.

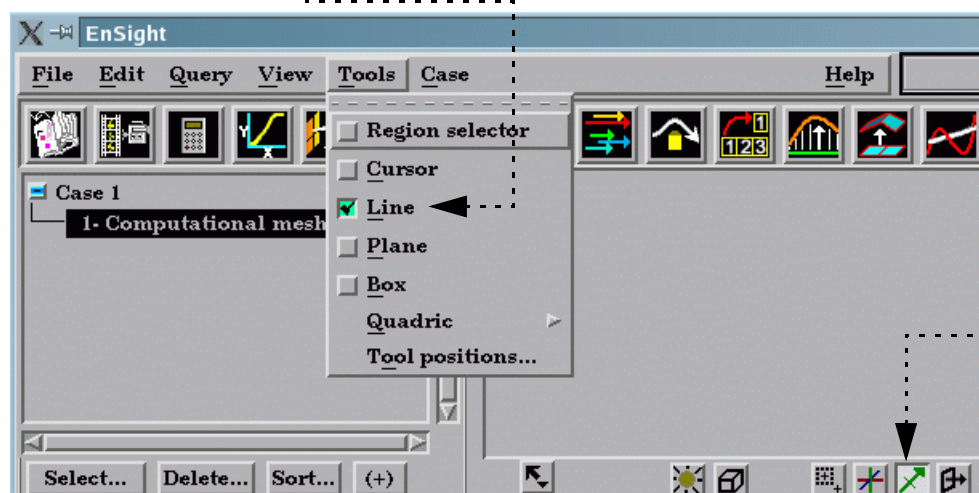

The Line tool can be placed in three ways: interactively through direct manipulation of tool “hotpoints” with the mouse, by positioning the mouse pointer over a part and typing the ‘p’ key, or precisely positioned by typing coordinates into a dialog.

To move the Line with the mouse:

1. Place the mouse pointer over the center of the tool.
2. Click (and hold) the left mouse button.
3. Drag the Line to the desired location.
4. Release the mouse button.

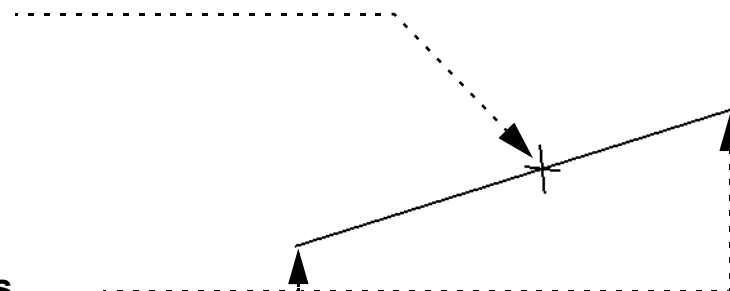

To stretch the Line with the mouse:

1. Place the mouse pointer over one of the Line endpoints.
2. Click (and hold) the left mouse button.
3. Drag the endpoint to the desired location.
4. Release the mouse button.

Note that the mouse pointer will change when it is over a hotspot (if you are in Part or Frame mode).

(Undo/Redo button at the bottom of screen can be used to undo/redo the tool transformation)

Line moving and stretching is restricted to the plane perpendicular to your line of sight. If you need to move the Line in another plane, rotate the model such that the desired translation plane is perpendicular to your new line of sight. (Note that the Line will not exactly track the location of the mouse pointer.)



To position the Line on a part with the 'p' key:

1. Click the Pick button in the global area above the graphics window on the desktop.
2. Select "Pick line tool location" from the pop-up menu.
3. In the Graphics Window, place the mouse pointer on a part over the desired location for the first Line endpoint and press the 'p' key (or whatever mouse button you have set for the "Selected Pick Action" in Edit > Preferences > Mouse and Keyboard).
4. Move the mouse pointer to the desired location for the second Line endpoint and again press the 'p' key.

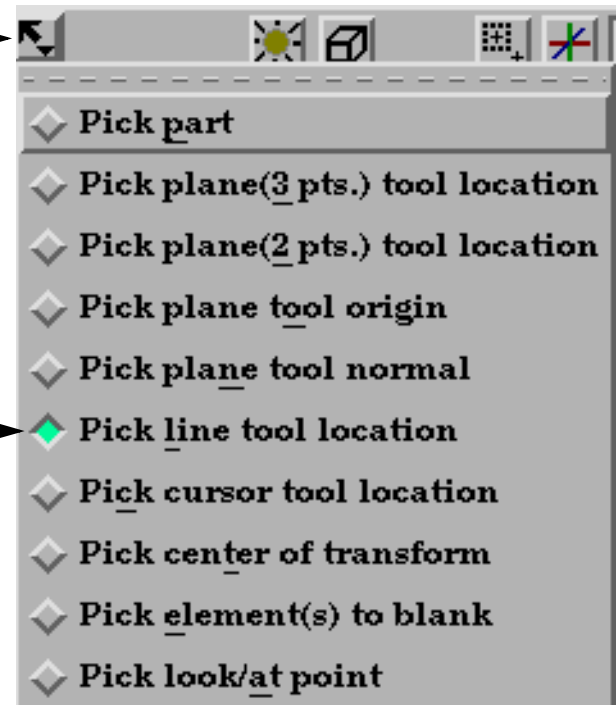

To set the Line by specifying coordinates:

1. Open the Transformation Editor dialog by clicking Transf... on the desktop.
2. Select Editor Function > Tools > Line.
3. Enter the desired coordinates for the endpoints into the X, Y, and Z fields and press return.

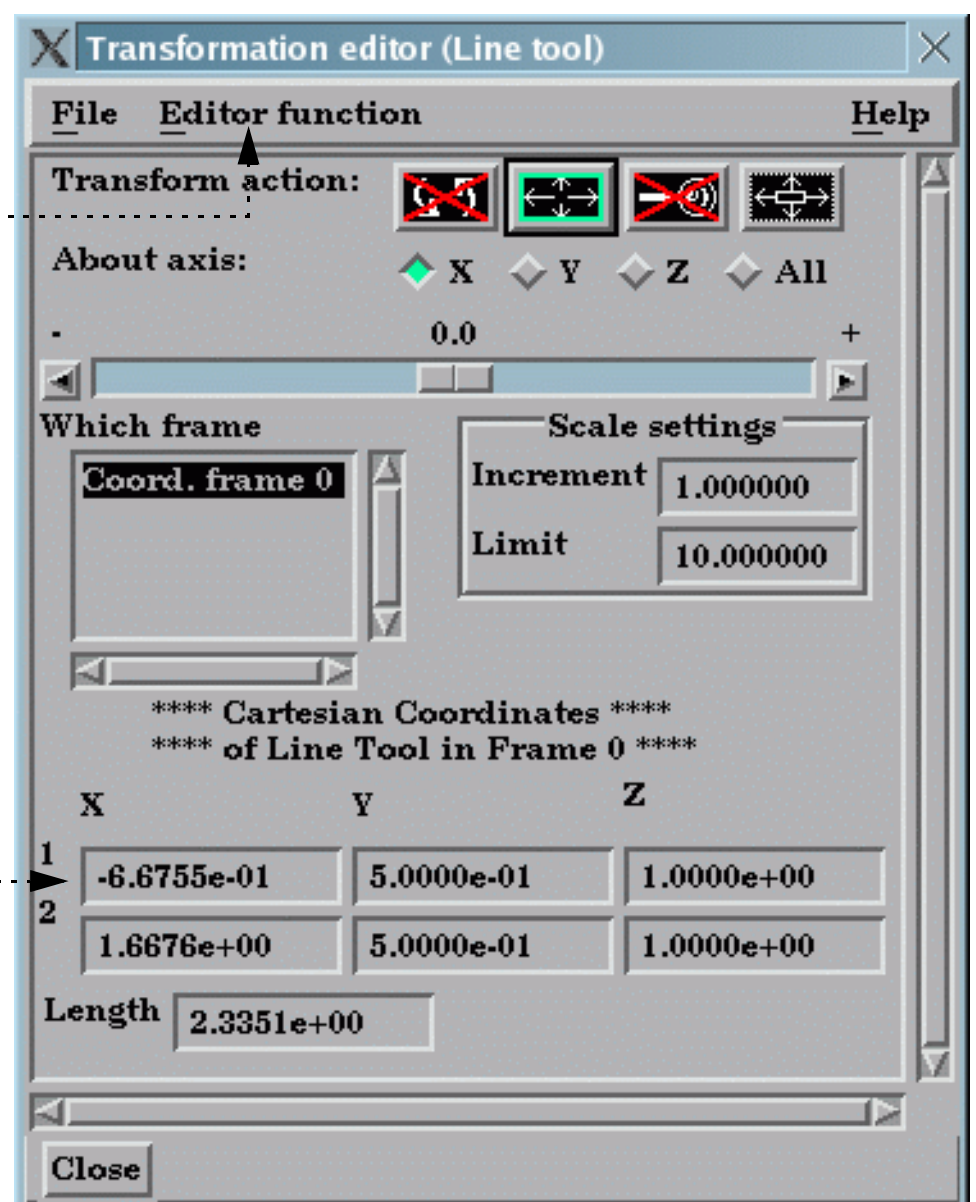

You can also move the Line by setting the desired axis of translation in the Axis pop-up and manipulating the slider bar. In this case, the values in the "Scale Settings" section control the sensitivity and limit of the slider action.

Note that you can also use this dialog to view (rather than set) the position of the Line since the X,Y,Z numeric values always update to reflect the current location. If you are positioning the Line interactively with the mouse, the values will update when the mouse button is released.



ADVANCED USAGE

After a model has been loaded, the initial location of the Line center is set to the “look-at” point – the geometric center of all visible geometry and parallel to the X axis. The coordinates of the Line are specified with respect to the default frame: frame 0. However, if you have created additional **frames**, you can position the Line relative to the origin of a different frame. This is accomplished by selecting the desired frame in the “Which Frame” list in the Transformation Editor dialog.

You can easily reset the position and orientation of the Line tool to the default. See [How To Reset Tools and Viewports](#) for more information.

Positioning a 3D tool with a 2D device (the mouse) can be difficult. Multiple **viewports** are sometimes helpful in positioning tools since you can see the tool simultaneously from multiple vantage points.

To find the distance between two nodes that have IDs, you can use the calculator function Dist2Nodes. However, to find the distance between two nodes on different parts, or between two nodes if one or both don't have IDs, use the line tool. First drag down to Pick Line Tool Location on the pick part icon to the left of the GUI screen, then move the cursor over the first location, hit ‘p’ key, move to the second location and hit the ‘p’ key, then open up the transformation editor and in the transformation editor menu, Edit>Tools>Line you'll find the length of the line tool which is the distance between those two points.

SEE ALSO

Other tools: [Cursor](#), [Plane](#), [Box](#), [Cylinder](#), [Sphere](#), [Cone](#), [Surface of Revolution](#). See the How To article on [Frames](#) for additional information on how frames effect tools.

User Manual: [Tools Menu Functions](#)



Use the Plane Tool

INTRODUCTION

EnSight provides a plane specification tool called the “Plane” tool. When visible, the Plane tool appears as a (typically white) rectangular region with an axis located at the center point. The Plane can also have a semi-transparent “filled” center that enhances visibility of the region. The Plane tool is used to supply EnSight with a planar specification, for example to specify the location for a planar clip or a “net” for a particle trace.

BASIC OPERATION

In many cases, the Plane tool will automatically turn on when performing some function that requires it. You can also turn the tool on and off manually by toggling one of the Plane entries in the Tools menu (e.g. Tools > Plane) or by clicking the Plane toggle on the Desktop.

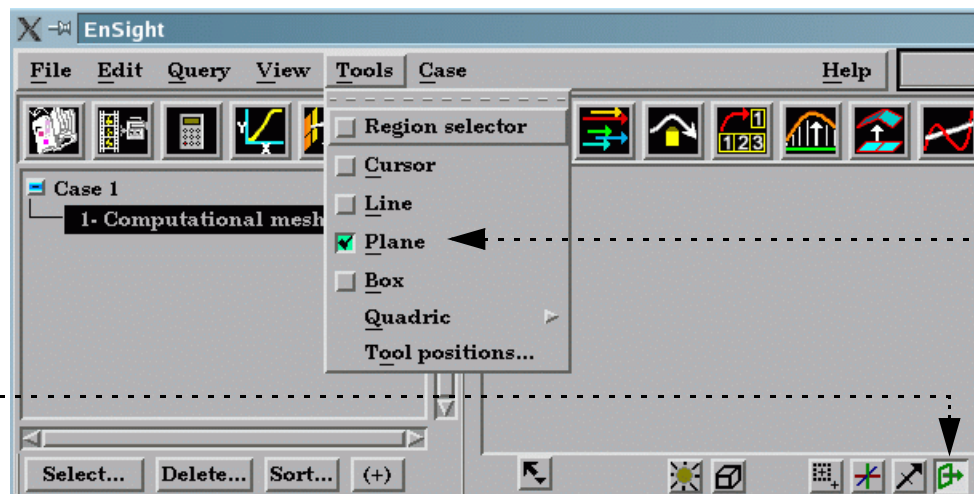

The Plane tool can be placed in three ways: interactively through direct manipulation of tool “hotpoints” with the mouse, by positioning the mouse pointer over a part and typing the ‘p’ key, or precisely positioned by typing coordinates into a dialog.

To move the Plane with the mouse:

1. Place the mouse pointer over the center of the tool.
2. Click (and hold) the left mouse button.
3. Drag the Plane to the desired location.
4. Release the mouse button.

To stretch (or scale) the Plane with the mouse:

1. Place the mouse pointer over the corner between the X and Y axis labels.
2. Click (and hold) the left mouse button.
3. Drag the corner to the desired location.
4. Release the mouse button.

To rotate the Plane tool with the mouse:

1. Place the mouse pointer over one of the axis labels (X, Y, or Z).
2. Click and drag to the desired orientation. Grabbing the X (Y) label will rotate around the plane’s Y (X) axis. Grabbing the Z label enables free rotation about the Plane’s center point.

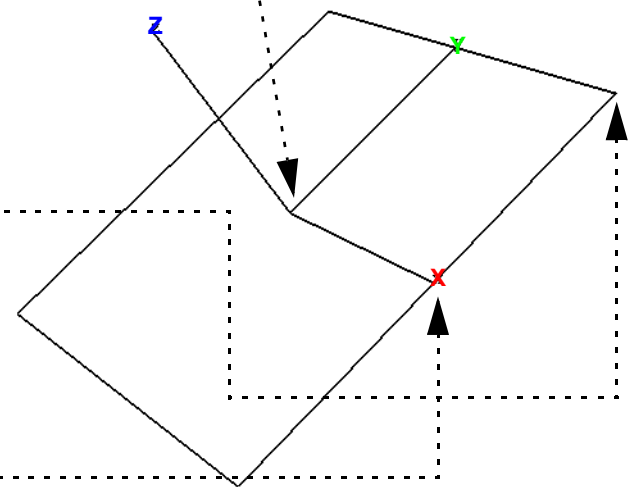

Note that the mouse pointer will change when it is over a hotspot (if you are in Part or Frame mode).

(Undo/Redo button at the bottom of screen can be used to undo/redo the tool transformation)

Plane moving is restricted to the plane perpendicular to your line of sight. If you need to move the Plane in another plane, rotate the model such that the desired translation plane is perpendicular to your new line of sight. (Note that the Plane will not exactly track the location of the mouse pointer.)



To position the Plane on a part (by specifying three points) with the 'p' key:

1. Click the Pick button in the global area above the graphics window on the desktop.
2. Select "Pick plane (3 Pts.) tool location" from the pop-up menu.
3. In the Graphics Window, place the mouse pointer on a part and press the 'p' key (or whatever mouse button you have set for the "Selected Pick Action" in Edit > Preferences > Mouse and Keyboard).
4. Repeat two more times. Note that you are not specifying corner points – just three unique points.

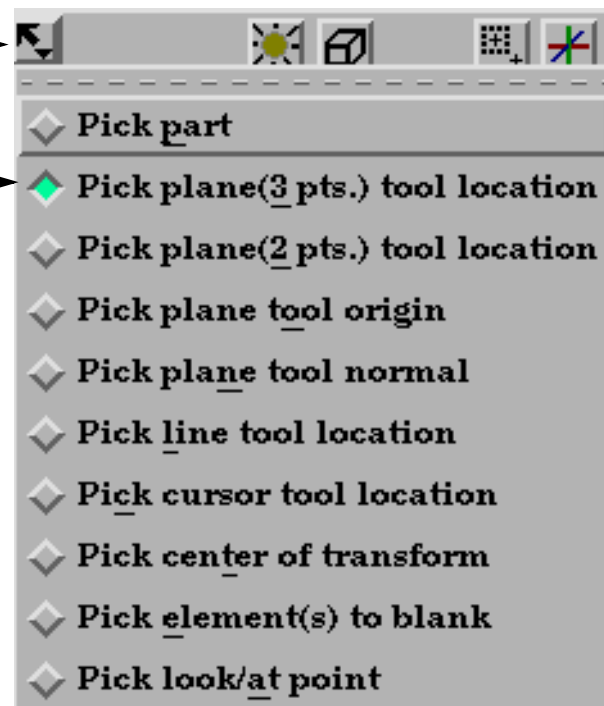

You can also position the Plane Tool by tracing out a line on the screen. The Plane orientation will be changed such that it is both parallel to the specified line and perpendicular to the screen.

To position the Plane (by specifying a line):

1. Click the Pick button in the global area above the graphics window on the desktop.
2. Select "Pick plane (2 Pts.) tool location" from the pop-up menu.
3. Move the mouse pointer into the Graphics Window and press the 'p' key. Place the pointer over the desired starting point. Click and hold the left mouse button as you trace out the desired line.
4. Release the mouse button.

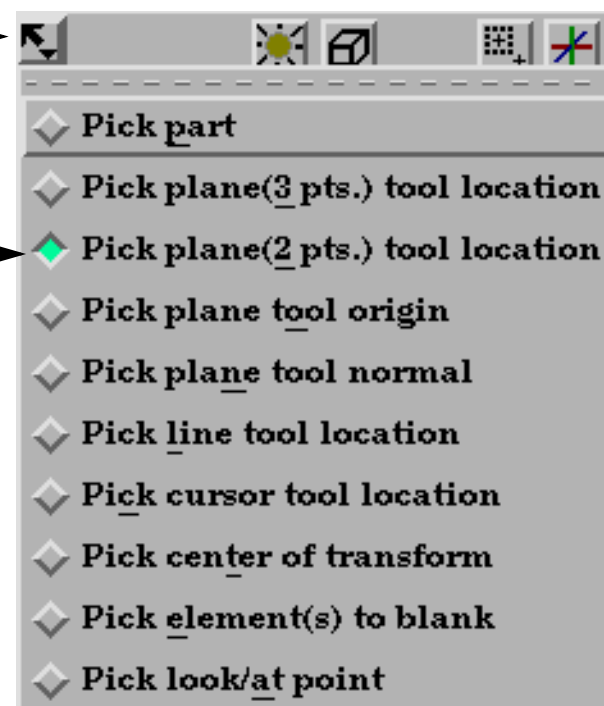

You can also position the Plane Tool by picking an origin, then a point out on the normal. This takes two picking operations to accomplish.

To position the Plane (by picking origin, then point on normal):

1. Click the Pick button in the global area above the graphics window on the desktop.
2. Select "Pick plane tool origin" from the pop-up menu.
3. Move the mouse pointer into the Graphics Window and place the pointer over the desired origin of the plane tool - then press the 'p' key.
4. Select "Pick plane tool normal" from the pop-up menu.
5. Place the pointer over a point along the normal vector (from the origin of the plane tool) - then press the 'p' key.

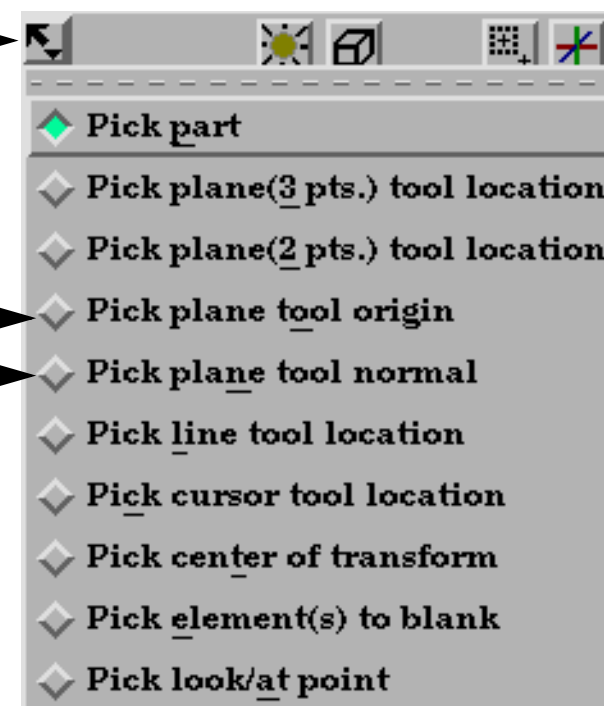



To set the Plane by specifying coordinates:

1. Open the Transformation Editor dialog from the desktop by clicking Transf...

2. Select Editor Function > Tools > Plane.

3. Enter the desired coordinates for the origin, the components of the normal vector, and the x and y size, and press return.

– OR –

3. Enter the plane equation parameters ($Ax + By + Cz = D$) and press return.

– OR –

3. Enter the desired coordinates for three corner points into the X, Y, and Z fields and press return.

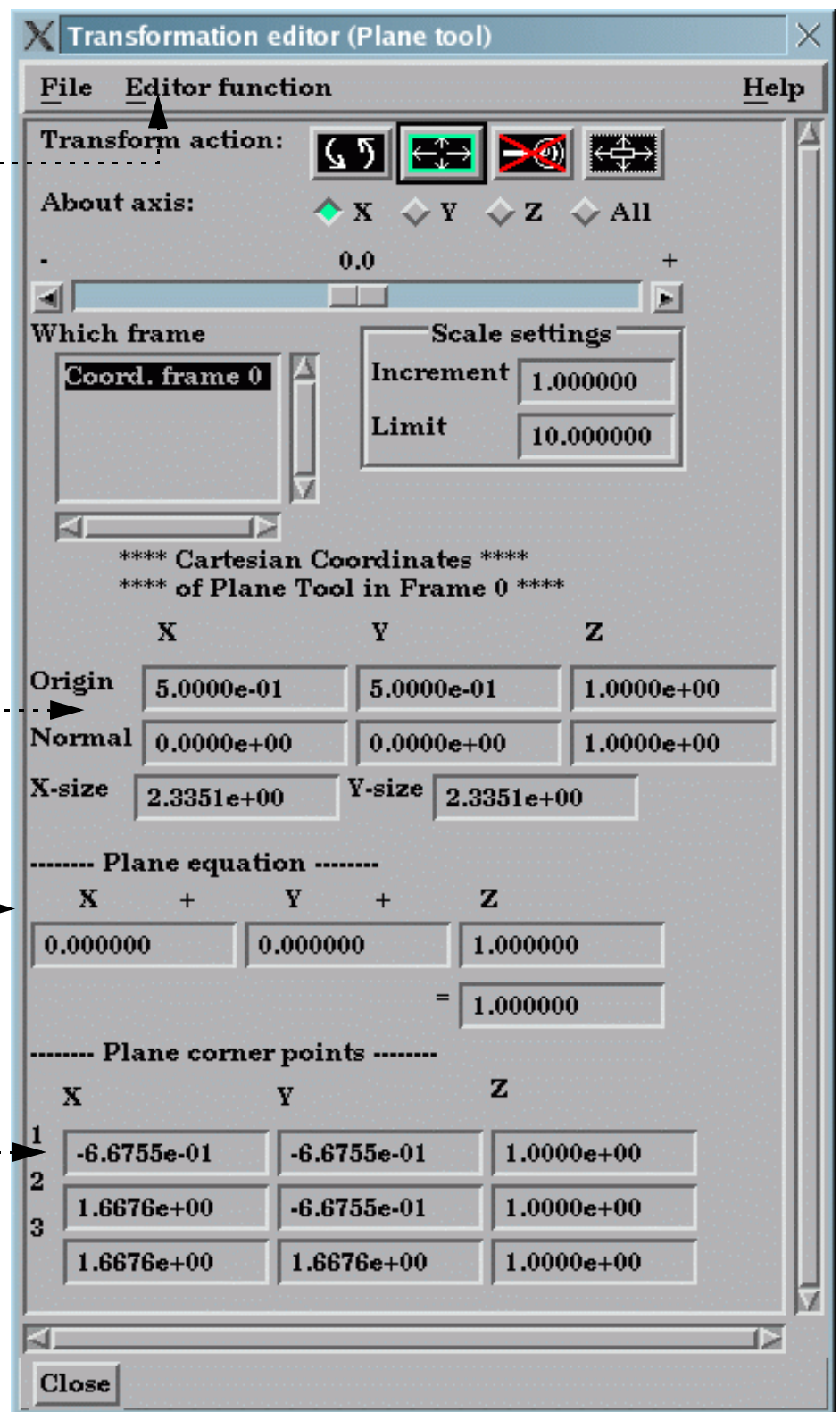

You can also rotate the Plane by setting the desired axis of rotation in the Axis pop-up and manipulating the slider bar. In this case, the values in the “Scale Settings” section control the sensitivity and limit of the slider action.

Note that you can also use this dialog to view (rather than set) the position of the Plane since the X,Y,Z numeric values always update to reflect the current location. If you are positioning the Plane interactively with the mouse, the values will update when the mouse button is released.

The Undo/Redo button at the bottom of screen can be used to undo/redo the tool transformation.

ADVANCED USAGE

After a model has been loaded, the initial location of the Plane center is set to the “look-at” point – the geometric center of all visible geometry and parallel to the X-Y plane. The coordinates of the Plane are specified with respect to the default frame: frame 0. However, if you have created additional **frames**, you can position the Plane relative to the origin of a different frame. This is accomplished by selecting the desired frame in the “Which Frame” list in the Transformation Editor dialog.

You can easily reset the position and orientation of the Plane tool to the default. See [How To Reset Tools and Viewports](#) for more information.

By default the plane tool will be displayed in line mode. You can display the tool as a transparent plane by changing the setting for Edit > Preferences... View - Plane Tool Filled.

Positioning a 3D tool with a 2D device (the mouse) can be difficult. Multiple **viewports** are sometimes helpful in positioning tools since you can see the tool simultaneously from multiple vantage points.



SEE ALSO

Other tools: [Cursor](#), [Line](#), [Box](#), [Cylinder](#), [Sphere](#), [Cone](#), [Surface of Revolution](#). See the How To article on [Frames](#) for additional information on how frames effect tools.

The Plane Tool is also used to specify the location of the clip plane for [Auxiliary Clipping](#).

User Manual: [Tools Menu Functions](#)



Use the Box Tool

INTRODUCTION

EnSight provides a hexahedron shaped specification tool called the “Box” tool. When visible, the Box tool appears as a (typically white) wireframe box icon with a triad at one corner. The Box tool is used to supply EnSight with a 3D volume specification, for example to specify the location for a box clip or cut.

BASIC OPERATION

In many cases, the Box tool will automatically turn on when performing some function that requires it. You can also turn the tool on and off manually by toggling Tools > Box.....

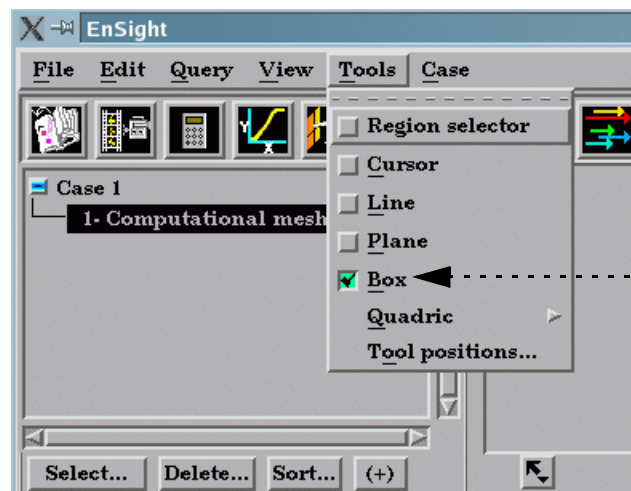

The Box tool can be placed in two ways: interactively through direct manipulation of tool “hotpoints” with the mouse or precisely positioned by typing coordinates into a dialog.

To move the Box Tool with the mouse:

1. Place the mouse pointer over the origin corner of the tool.
2. Click (and hold) the left mouse button.
3. Drag the Box to the desired location.
4. Release the mouse button.

To stretch the Box Tool with the mouse:

1. Place the mouse pointer over any of the corner points (except the origin).
2. Click (and hold) the left mouse button.
3. Drag the endpoint to produce the desired stretched size.
4. Release the mouse button.

To rotate the Box Tool with the mouse:

1. Place the mouse pointer over the center of the x, y, or z edge(not at the endpoints).
2. Click and drag to rotate.

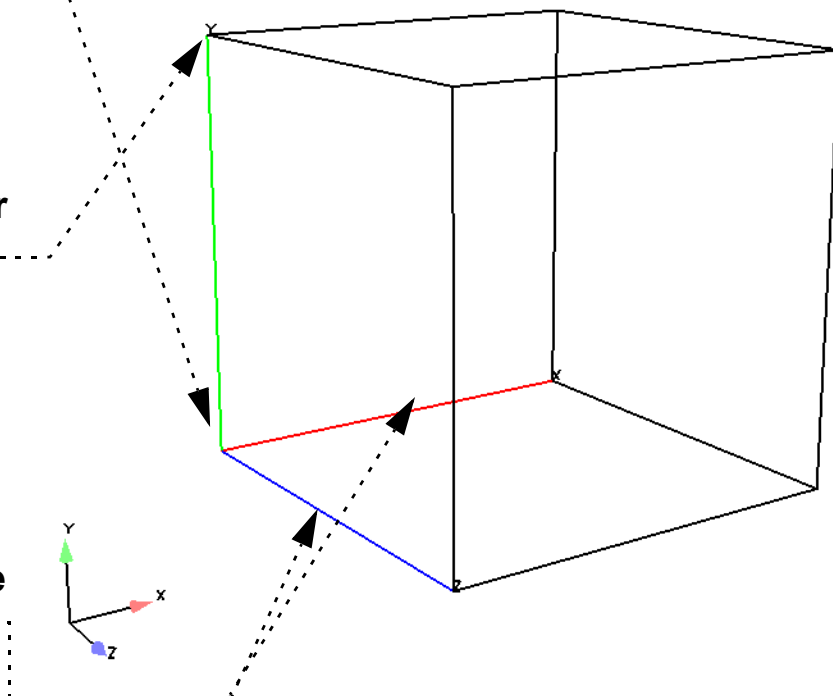

Note: Selection of the X axis edge will rotate the box about the Y axis edge. Selection of the Y axis edge will rotate about the X axis edge. Selection about the Z axis edge will rotate about the origin.

Note that the mouse pointer will change when it is over a hotspot (if you are in Part or Frame mode).

(Undo/Redo button at the bottom of screen can be used to undo/redo the tool transformation)

Box tool moving and stretching is in 3 space. (Note the Box may not exactly track the location of the mouse pointer.)





To set the Box Tool by specifying coordinates:

1. Open the Transformation Editor dialog by clicking Transf... on the desktop.
2. Select Editor Function > Tools > Box.....
3. To place and size, enter the desired coordinates for the Origin corner and the length in each of the directions, and press return.
4. To orient, enter the components of the orthogonal axis orientation vectors

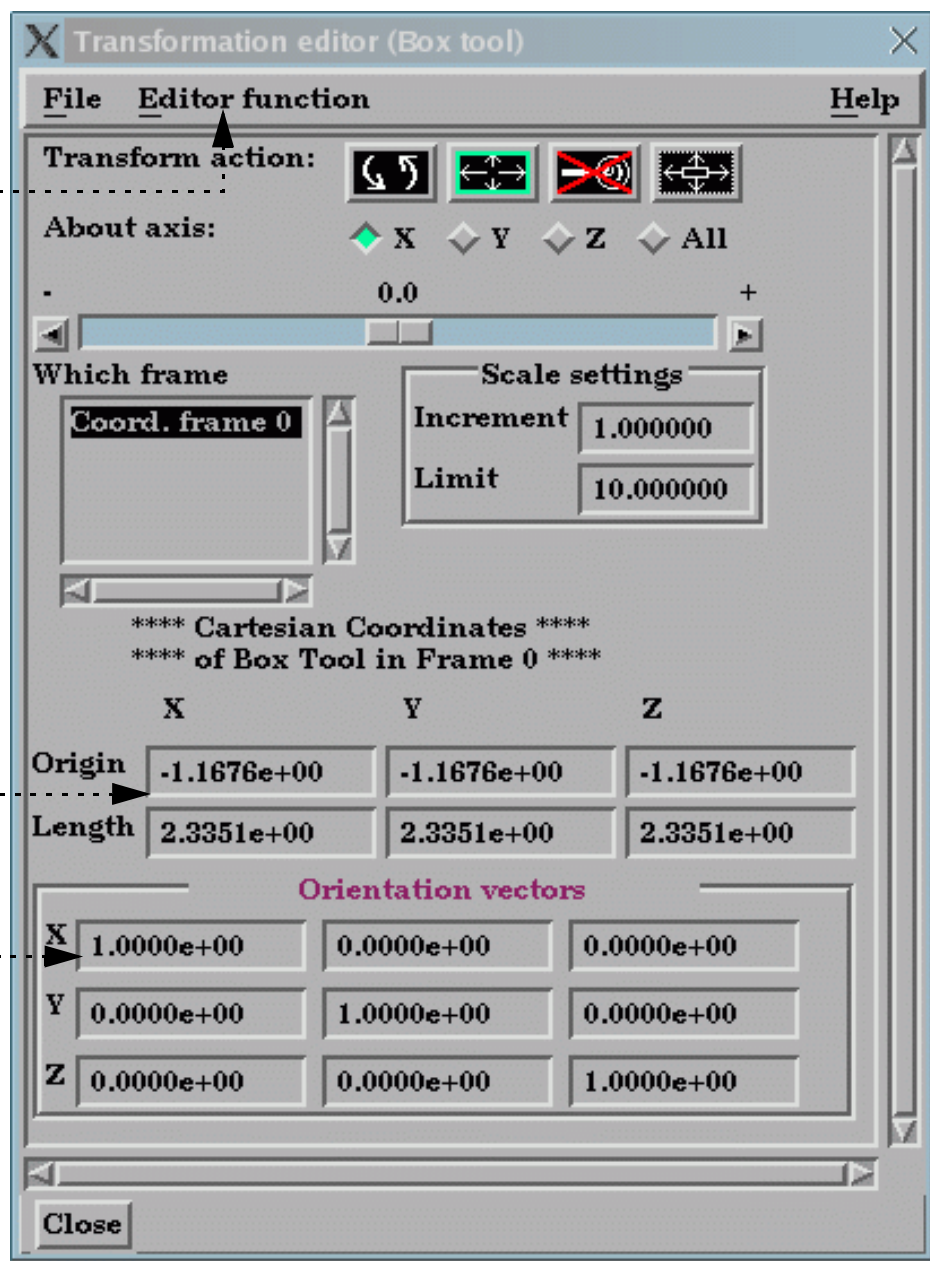

You can also rotate, translate or stretch the Box Tool by selecting the desired Transform Action, setting the desired axis, and then manipulating the slider bar. For these tool actions, the values in the “Scale Settings” section control the sensitivity and limit of the slider action.

Note that you can also use this dialog to view (rather than set) the position of the Box Tool since the numeric values always update to reflect the current location, size, and orientation. If you are positioning the Box Tool interactively with the mouse, the values will update when the mouse button is released.

ADVANCED USAGE

After a model has been loaded, the initial location of the Box Tool is centered about the “look-at” point – the geometric center of all visible geometry - and is aligned with the model axis system. The coordinates of the Cylinder are specified with respect to the default frame: frame 0. However, if you have created additional **frames**, you can position the Box Tool relative to the origin of a different frame. This is accomplished by selecting the desired frame in the “Which Frame” list in the Transformation Editor dialog.

You can easily reset the position and orientation of the Box tool to the default. See [How To Reset Tools and Viewports](#) for more information.

Positioning a 3D tool with a 2D device (the mouse) can be difficult. Multiple **viewports** are sometimes helpful in positioning tools since you can see the tool simultaneously from multiple vantage points.

SEE ALSO

Other tools: [Cursor](#), [Line](#), [Plane](#), [Cylinder](#), [Sphere](#), [Cone](#), [Surface of Revolution](#). See the How To article on [Frames](#) for additional information on how frames effect tools.

User Manual: [Tools Menu Functions](#)



Use the Cylinder Tool

INTRODUCTION

EnSight provides a cylindrical specification tool called the “Cylinder” tool. When visible, the Cylinder tool appears as a (typically white) cylinder icon with a line running down the central axis. The Cylinder tool is used to supply EnSight with a cylindrical specification, for example to specify the location for a cylinder clip or cut.

BASIC OPERATION

In many cases, the Cylinder tool will automatically turn on when performing some function that requires it. You can also turn the tool on and off manually by toggling Tools > Quadric > Cylinder. The Cylinder tool can be placed in two ways: interactively through direct manipulation of tool “hotpoints” with the mouse or precisely positioned by typing coordinates into a dialog.

To move the Cylinder with the mouse:

1. Place the mouse pointer over the center of the tool.
2. Click (and hold) the left mouse button.
3. Drag the Cylinder to the desired location.
4. Release the mouse button.

To stretch the Cylinder with the mouse:

1. Place the mouse pointer over either of the center line’s endpoints.
2. Click (and hold) the left mouse button.
3. Drag the endpoint to the desired location.
4. Release the mouse button.

To change the Cylinder radius with the mouse:

1. Place the mouse pointer over the center ring.
2. Click and drag to the desired radius.

Note that the mouse pointer will change when it is over a hotpoint (if in Part or Frame mode).

(Undo/Redo button at the bottom of screen can be used to undo/redo the tool transformation)

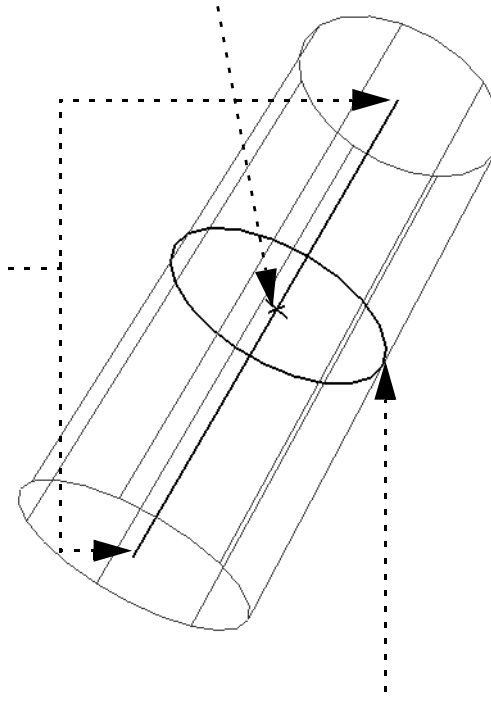

Cylinder moving and stretching is restricted to the plane perpendicular to your line of sight. If you need to move the Cylinder in another plane, rotate the model such that the desired translation plane is perpendicular to your new line of sight. (Note that the Cylinder will not exactly track the location of the mouse pointer.)



To set the Cylinder by specifying coordinates:

1. Open the Transformation Editor dialog by clicking Transf... on the desktop.

2. Select Editor Function > Tools > Cylinder.

3. Enter the desired coordinates for the Origin (location of the center point), the Axis (direction vector), and the Radius and press return.

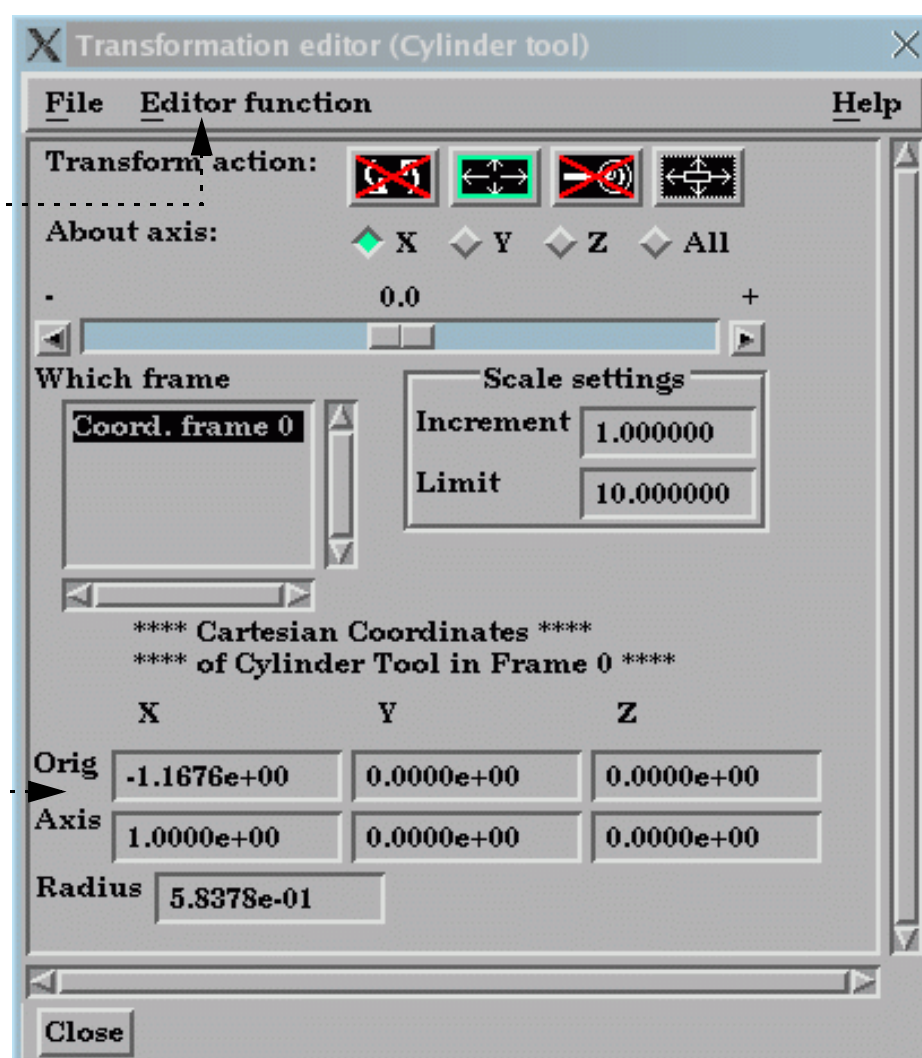

You can also translate the Cylinder by setting the desired axis of translation in the Axis pop-up and manipulating the slider bar. In this case, the values in the “Scale Settings” section control the sensitivity and limit of the slider action.

Note that you can also use this dialog to view (rather than set) the position of the Cylinder since the numeric values always update to reflect the current location. If you are positioning the Cylinder interactively with the mouse, the values will update when the mouse button is released.

ADVANCED USAGE

After a model has been loaded, the initial location of the Cylinder center is set to the “look-at” point – the geometric center of all visible geometry and aligned with the X axis. The coordinates of the Cylinder are specified with respect to the default frame: frame 0. However, if you have created additional **frames**, you can position the Cylinder relative to the origin of a different frame. This is accomplished by selecting the desired frame in the “Which Frame” list in the Transformation Editor dialog.

You can easily reset the position and orientation of the Cylinder tool to the default. See [How To Reset Tools and Viewports](#) for more information.

Positioning a 3D tool with a 2D device (the mouse) can be difficult. Multiple **viewports** are sometimes helpful in positioning tools since you can see the tool simultaneously from multiple vantage points.

SEE ALSO

Other tools: [Cursor](#), [Line](#), [Plane](#), [Box](#), [Sphere](#), [Cone](#), [Surface of Revolution](#). See the How To article on [Frames](#) for additional information on how frames effect tools.

User Manual: [Tools Menu Functions](#)



Use the Sphere Tool

INTRODUCTION

EnSight provides a spherical specification tool called the “Sphere” tool. When visible, the Sphere tool appears as a (typically white) sphere icon with a line running down the central axis. The Sphere tool is used to supply EnSight with a spherical specification, for example to specify the location for a sphere clip or cut.

BASIC OPERATION

In many cases, the Sphere tool will automatically turn on when performing some function that requires it. You can also turn the tool on and off manually by toggling Tools > Quadric > Sphere. The Sphere tool can be placed in two ways: interactively through direct manipulation of tool “hotpoints” with the mouse or precisely positioned by typing coordinates into a dialog.

To move the Sphere with the mouse:

1. Place the mouse pointer over the center of the tool.
2. Click (and hold) the left mouse button.
3. Drag the Sphere to the desired location.
4. Release the mouse button.

To stretch the Sphere with the mouse:

1. Place the mouse pointer over either of the center line’s endpoints.
2. Click (and hold) the left mouse button.
3. Drag the endpoint to the desired location.
4. Release the mouse button.

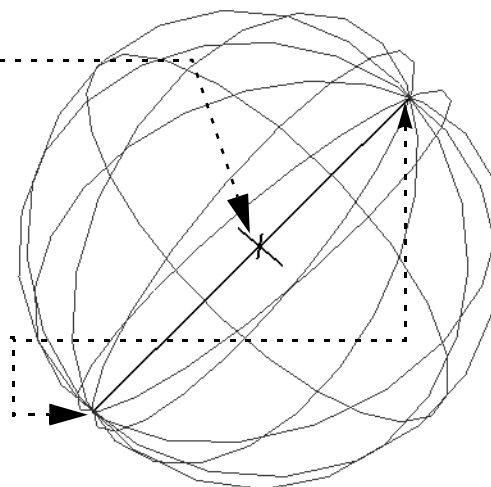

Note that the mouse pointer will change when it is over a hotpoint (if in Part or Frame mode).

(Undo/Redo button at the bottom of screen can be used to undo/redo the tool transformation)

Sphere moving and stretching is restricted to the plane perpendicular to your line of sight. If you need to move the Sphere in another plane, rotate the model such that the desired translation plane is perpendicular to your new line of sight. (Note that the Sphere will not exactly track the location of the mouse pointer.)

To set the Sphere by specifying coordinates:

1. Open the Transformation Editor dialog by clicking Transf... on the desktop.

2. Select Editor Function > Tools > Sphere.

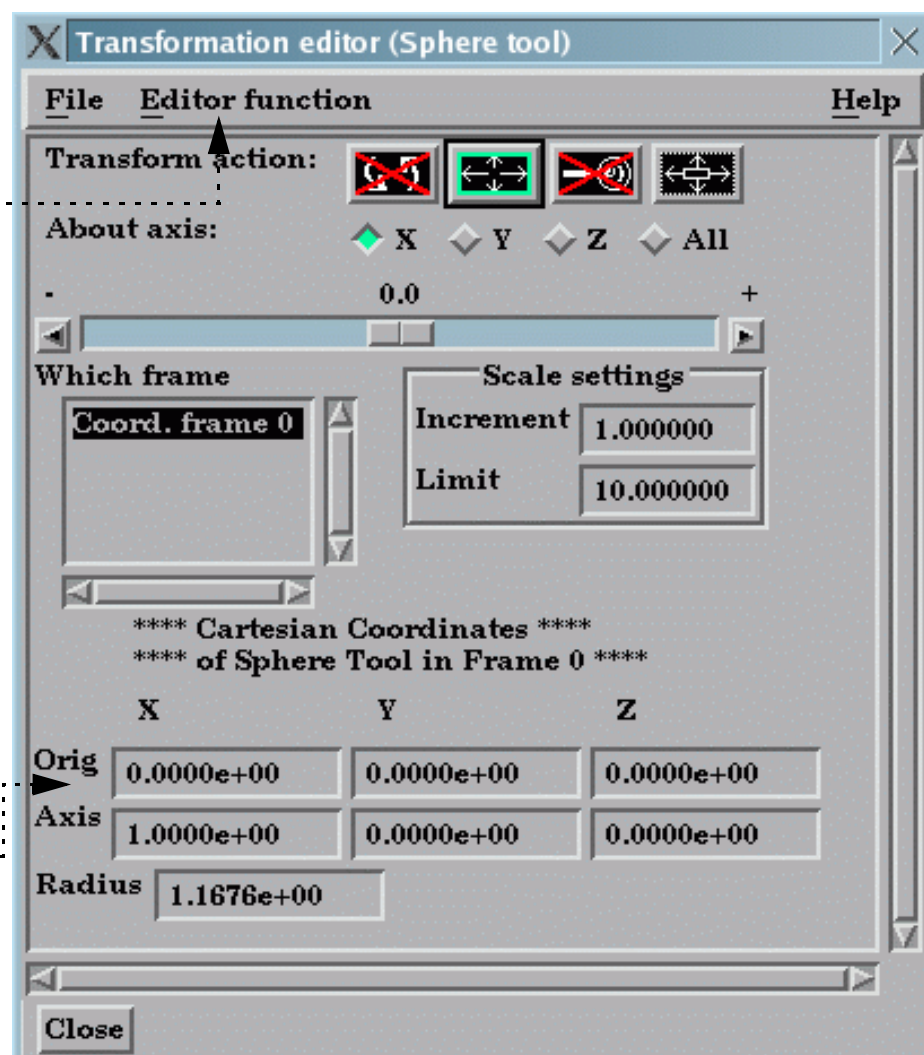

3. Enter the desired coordinates for the Origin (location of the center point), the Axis (direction vector), and/or the Radius and press return.

if you are going to create a developed surface from a spherical clip, you need to be aware of how the spherical axis orientation affects this operation.

(See [How To Create a Developed Surface](#))



You can also translate the Sphere by setting the desired axis of translation in the Axis pop-up and manipulating the slider bar. In this case, the values in the “Scale Settings” section control the sensitivity and limit of the slider action.

Note that you can also use this dialog to view (rather than set) the position of the Sphere since the numeric values always update to reflect the current location. If you are positioning the Sphere interactively with the mouse, the values will update when the mouse button is released.

ADVANCED USAGE

After a model has been loaded, the initial location of the Sphere center is set to the “look-at” point – the geometric center of all visible geometry and aligned with the X axis. The coordinates of the Sphere are specified with respect to the default frame: frame 0. However, if you have created additional **frames**, you can position the Sphere relative to the origin of a different frame. This is accomplished by selecting the desired frame in the “Which Frame” list in the Transformation Editor dialog.

You can easily reset the position and orientation of the Sphere tool to the default. See [How To Reset Tools and Viewports](#) for more information.

Positioning a 3D tool with a 2D device (the mouse) can be difficult. Multiple **viewports** are sometimes helpful in positioning tools since you can see the tool simultaneously from multiple vantage points.

SEE ALSO

Other tools: [Cursor](#), [Line](#), [Plane](#), [Box](#), [Cylinder](#), [Cone](#), [Surface of Revolution](#). See the How To article on [Frames](#) for additional information on how frames effect tools.

User Manual: [Tools Menu Functions](#)



Use the Cone Tool

INTRODUCTION

EnSight provides a conical specification tool called the “Cone” tool. When visible, the Cone tool appears as a (typically white) cone icon with a line running down the center axis. The Cone tool is used to supply EnSight with a conical specification, for example to specify the location for a conical clip or cut.

BASIC OPERATION

In many cases, the Cone tool will automatically turn on when performing some function that requires it. You can also turn the tool on and off manually by toggling Tools > Quadric > Cone. The Cone tool can be placed in two ways: interactively through direct manipulation of tool “hotpoints” with the mouse or precisely positioned by typing coordinates into a dialog.

To move the Cone with the mouse:

1. Place the mouse pointer over the center of the tool.
2. Click (and hold) the left mouse button.
3. Drag the Cone to the desired location.
4. Release the mouse button.

To stretch the Cone with the mouse:

1. Place the mouse pointer over either of the center line’s endpoints.
2. Click (and hold) the left mouse button.
3. Drag the endpoint to the desired location.
4. Release the mouse button.

To change the Cone radius with the mouse:

1. Place the mouse pointer over the base ring.
2. Click and drag to the desired radius.

Note that the mouse pointer will change when it is over a hotpoint (if in Part or Frame mode).

(Undo/Redo button at the bottom of screen can be used to undo/redo the tool transformation)

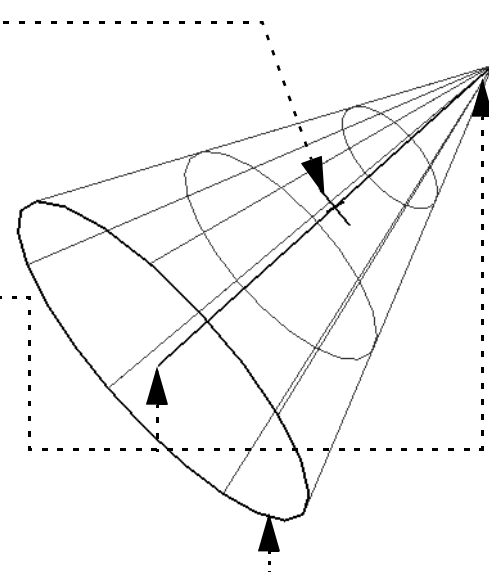

Cone moving and stretching is restricted to the plane perpendicular to your line of sight. If you need to move the Cone in another plane, rotate the model such that the desired translation plane is perpendicular to your new line of sight. (Note that the Cone will not exactly track the location of the mouse pointer.)



To set the Cone by specifying coordinates:

1. Open the Transformation Editor dialog by clicking Transf... on the desktop.
2. Select Editor Function > Tools > Cone.
3. Enter the desired coordinates for the Origin (location of the cone tip), the Axis (direction vector), and the conical half angle (in degrees) and press return.

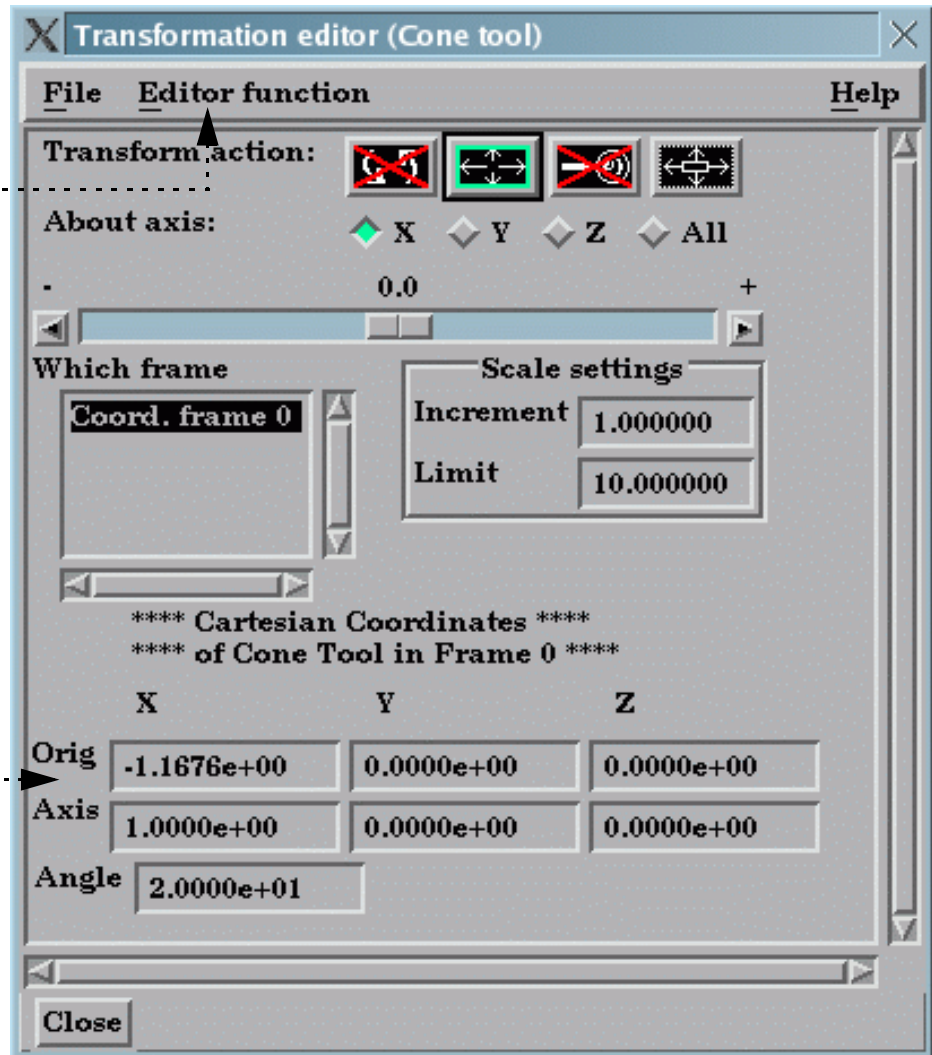

You can also translate the Cone by setting the desired axis of translation and manipulating the slider bar. In this case, the values in the “Scale Settings” section control the sensitivity and limit of the slider action.

Note that you can also use this dialog to view (rather than set) the position of the Cone since the numeric values always update to reflect the current location. If you are positioning the Cone interactively with the mouse, the values will update when the mouse button is released.

The clip/cut from the cone tool will extend infinitely from the tip outwards. To limit the extent of the cone clip/cut, use the plane tool and cut the cone clip/cut as desired.

ADVANCED USAGE

After a model has been loaded, the initial location of the Cone center is set to the “look-at” point – the geometric center of all visible geometry and aligned with the X axis. The coordinates of the Cone are specified with respect to the default frame: frame 0. However, if you have created additional **frames**, you can position the Cone relative to the origin of a different frame. This is accomplished by selecting the desired frame in the “Which Frame” list in the Transformation Editor dialog.

You can easily reset the position and orientation of the Cone tool to the default. See [How To Reset Tools and Viewports](#) for more information.

Positioning a 3D tool with a 2D device (the mouse) can be difficult. Multiple **viewports** are sometimes helpful in positioning tools since you can see the tool simultaneously from multiple vantage points.

SEE ALSO

Other tools: [Cursor](#), [Line](#), [Plane](#), [Box](#), [Cylinder](#), [Sphere](#), [Surface of Revolution](#). See the How To article on [Frames](#) for additional information on how frames effect tools.

User Manual: [Tools Menu Functions](#)



Use the Surface of Revolution Tool

INTRODUCTION

EnSight provides a surface of revolution specification tool called the “Revolution” tool. When visible, the Revolution tool appears as a (typically white) icon with a line running down the center axis. By default, the distance of five planar points from the central axis defines the profile curve of the revolution surface (although you can add points up to a maximum of ten). The Revolution tool is used to supply EnSight with a surface of revolution specification, for example to specify the location for a revolution clip or cut.

BASIC OPERATION

In many cases, the Revolution tool will automatically turn on when performing some function that requires it. You can also turn the tool on and off manually by toggling Tools > Quadric > Revolution. The Revolution tool can be placed in two ways: interactively through direct manipulation of tool “hotpoints” with the mouse or precisely positioned by typing coordinates into a dialog.

To move the Revolution tool with the mouse:

1. Place the mouse pointer over the center of the tool.
2. Click (and hold) the left mouse button.
3. Drag the tool to the desired location.
4. Release the mouse button.

To reorient the Revolution tool with the mouse:

1. Place the mouse pointer over either of the center line’s endpoints.
2. Click (and hold) the left mouse button.
3. Drag the endpoint to achieve the desired orientation.
4. Release the mouse button.

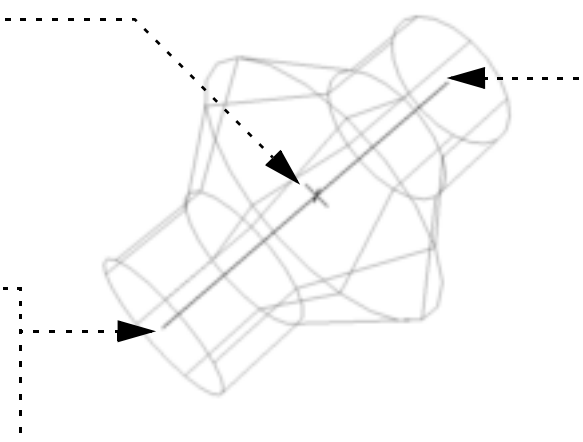

Note that the mouse pointer will change when it is over a hotspot (if in Part or Frame mode).

(Undo/Redo button at the bottom of screen can be used to undo/redo the tool transformation)

Revolution tool moving and stretching is restricted to the plane perpendicular to your line of sight. If you need to move the Revolution tool in another plane, rotate the model such that the desired translation plane is perpendicular to your new line of sight. (Note that the Revolution tool will not exactly track the location of the mouse pointer.)



To set the Revolution tool by specifying coordinates:

1. Open the Transformations dialog by clicking Transf... on the desktop.
2. Select Editor Function > Tools > Revolution.

The dialog displays the profile curve as a series of connected line segments with stars positioned at the curve points. You can edit the curve by clicking and dragging the points or by manually entering distance-radius pairs. You can also add or delete points. As you make changes, the tool in the graphics window updates interactively.

To edit points with the mouse:

1. Click on the point and drag to the desired location.

To add points (up to a maximum of 10):

1. Click Add Point.
2. Move the mouse pointer into the curve window and click the left mouse button in the location of the desired new point. Clicking Delete Point will remove the currently selected point.

To manually edit a point:

1. Click the point (to select it) in the curve window or click the desired point in either the Distance or Radius lists.
2. The distance and radius of the selected point are shown in the text fields below each list.
3. Edit the point's distance and/or radius value and press return.

To edit the position or orientation:

1. Enter the desired coordinates for the Origin (location of the axis center point) or Axis (direction vector) and press return.

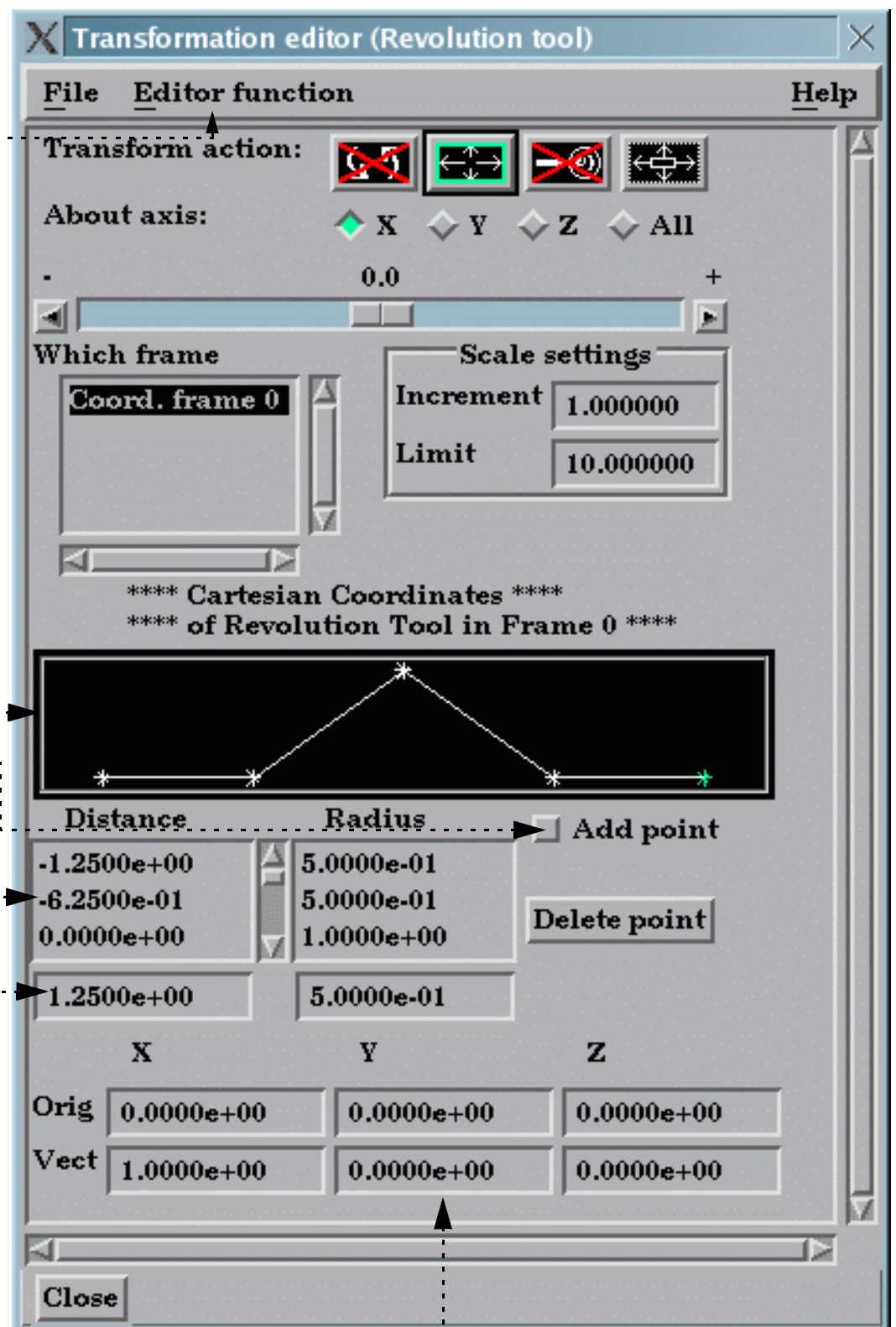

You can also translate the Revolution tool by setting the desired axis of translation in the Axis option menu and manipulating the slider bar. In this case, the values in the "Scale Settings" section control the sensitivity and limit of the slider action.

Note that you can also use this dialog to view (rather than set) the position of the Revolution tool since the numeric values always update to reflect the current location. If you are positioning the Revolution tool interactively with the mouse, the values will update when the mouse button is released.



ADVANCED USAGE

After a model has been loaded, the initial location of the Revolution tool center is set to the “look-at” point – the geometric center of all visible geometry and aligned with the X axis. The coordinates of the Revolution tool are specified with respect to the default frame: frame 0. However, if you have created additional **frames**, you can position the Revolution tool relative to the origin of a different frame. This is accomplished by selecting the desired frame in the “Which Frame” list in the Transformations dialog.

You can easily reset the position and orientation of the Revolution tool to the default. See [How To Reset Tools and Viewports](#) for more information.

Positioning a 3D tool with a 2D device (the mouse) can be difficult. Multiple **viewports** are sometimes helpful in positioning tools since you can see the tool simultaneously from multiple vantage points.

SEE ALSO

Other tools: [Cursor](#), [Line](#), [Plane](#), [Box](#), [Cylinder](#), [Sphere](#), [Cone](#). See the How To article on [Frames](#) for additional information on how frames effect tools.



Use the Selection Tool

INTRODUCTION

EnSight provides a 2D screen selection tool called the "Selection" tool or "Region Selector". It is different than most of the other tools - in that it is not used to create other parts. It is basically used for selection purposes. For example, it can be used to select a screen region to zoom in to. It can be used in the part selection process. And it can be used for the element blanking operation.

BASIC OPERATION

Zoom to Region

To use the selection tool to perform a zoom operation:

1. Click the Selection tool rubberband positioning button.

2. Click in the graphics window (to set one corner) and drag (to set the opposite corner) to place the selection tool.

3. Fine tune the location of the tool, if needed, by the methods described below.

4. Click the Zoom symbol, at the upper left of the tool, to cause the zoom to occur.

Note: the Undo button is useful if you want to undo the last transformation.

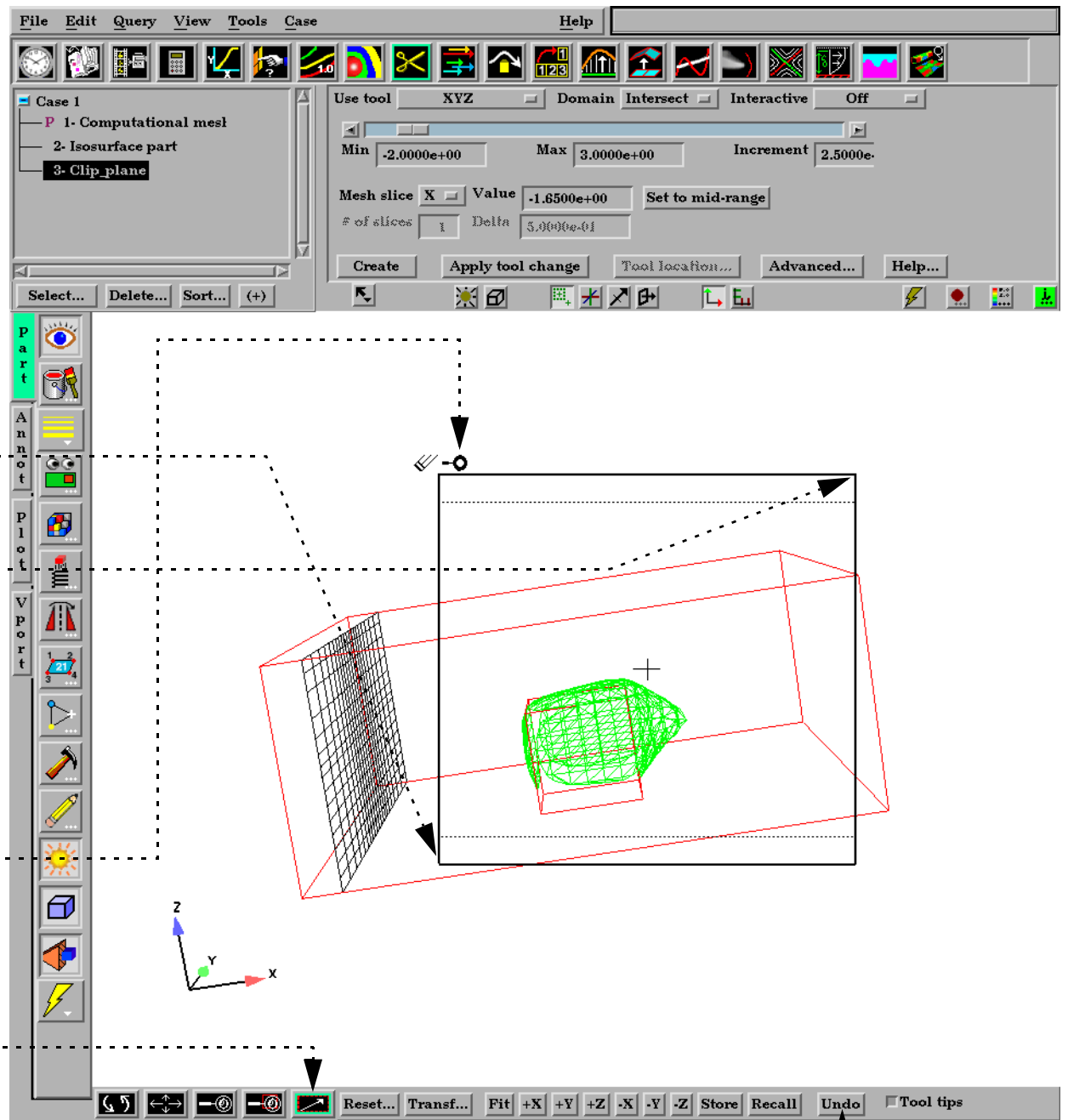

You manipulate the tool by:

- clicking and dragging on any corner to rubberband the tool.

- clicking and dragging on the center of the tool to move it.

Note: the dotted box indicates the actual region being used. It is preserving the aspect ratio.

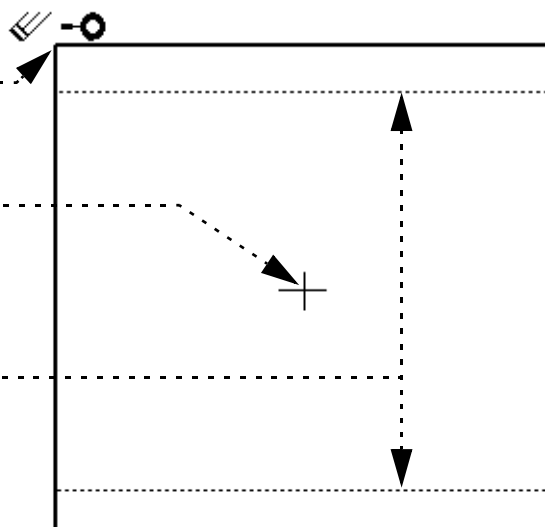



Element Blanking

The selection tool can be used in the element blanking operation.:

1. Select the part(s) on which to do element blanking.
2. Click on the Selection tool icon to turn on the tool.
3. Position the tool as desired.
4. Click on the element blanking symbol at the upper left of the tool.

Note, in order for this to work, the Element blanking allowed toggle needs to be on (the default).
To undo the blanking, click the Clear or Clear all parts button.

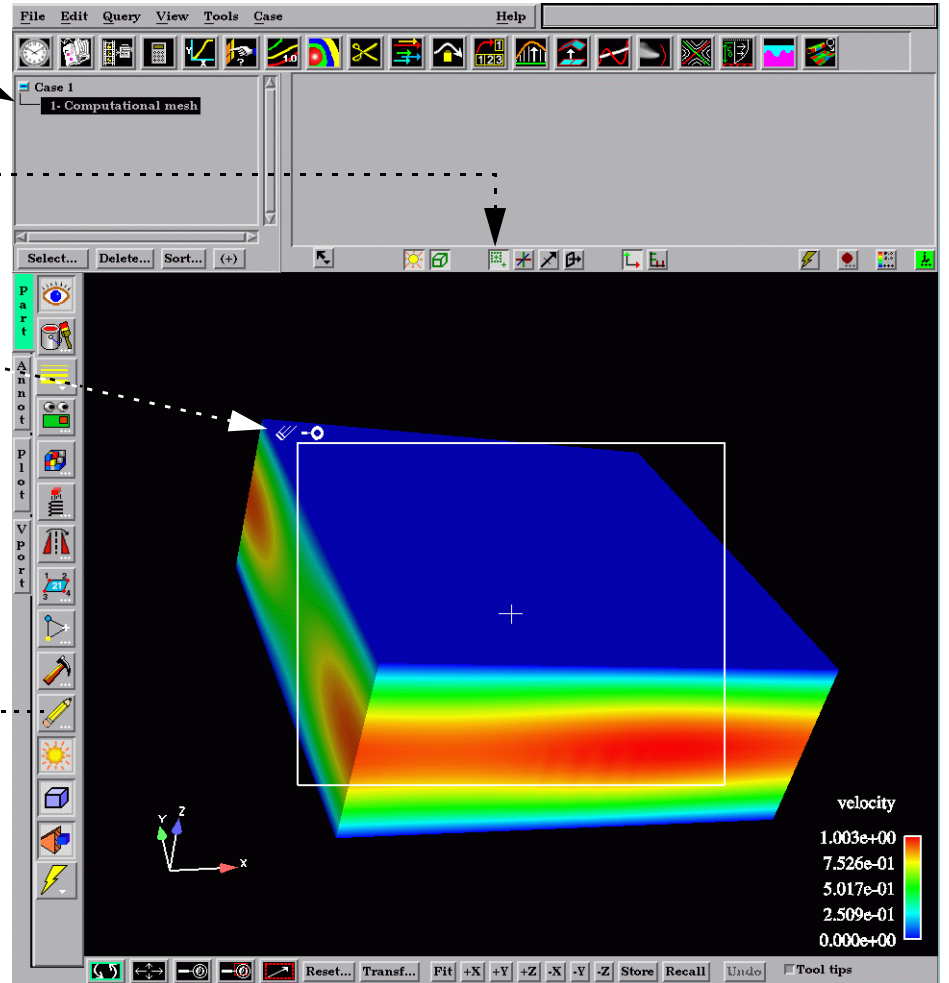

Results in the following:

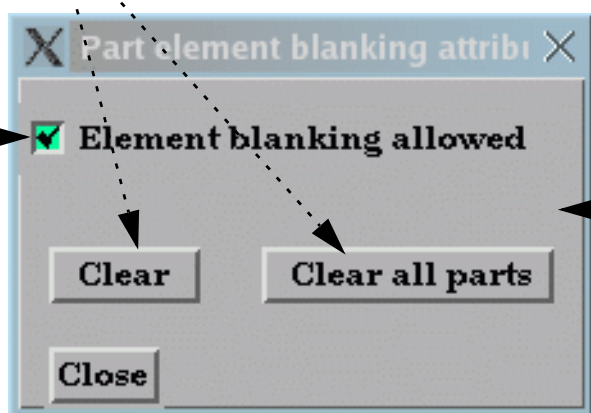
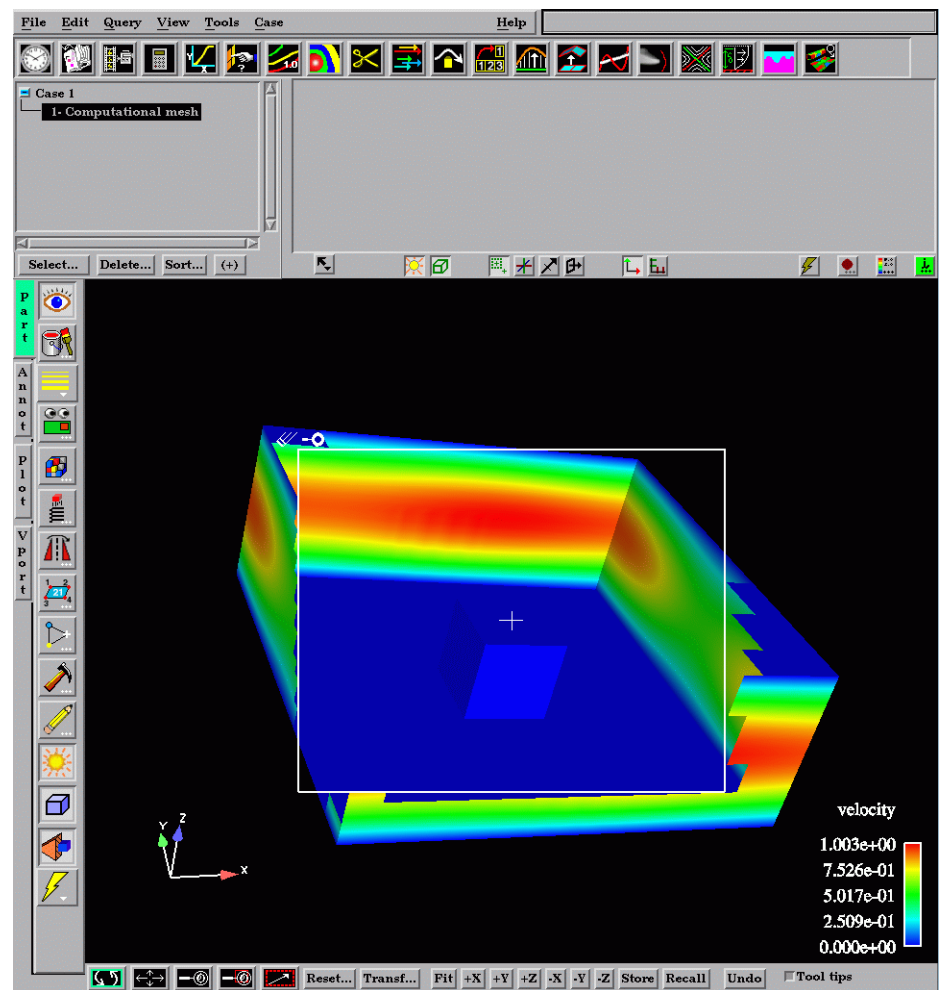



Part Selection

To use the tool in the part selection process:

1. Turn on the selection tool by clicking the icon:.....
2. Manipulate the tool until at least some portion of the desired parts are contained within the tool's dotted area.
3. Click the **Select...** button and select "Region"

Note that the selected parts will now be highlighted in the parts list.

SEE ALSO

[How To Do Element Blanking](#)

[How To Rotate, Zoom, Translate, Scale](#)

User Manual: [Tools Menu Functions](#)

INTRODUCTION

Much of the strength of EnSight derives from its flexible and powerful part creation mechanism. Since virtually every task you perform in EnSight will involve some form of part manipulation, it is vital to understand these concepts.

In EnSight, a *part* is a named collection of elements (or cells) and associated nodes. The nodes may have zero or more *variables* (such as pressure or stress) currently defined at the node positions. All components of a part share the same set of attributes (such as color or line width).

Parts are either built during the loading process (based on your computational mesh and associated surfaces) or created during an EnSight session. Parts created during loading are called *model parts*. Model parts can also be created during an EnSight session by performing a copy on other model parts.

All other parts are created during an EnSight session and are called *created* or *derived* parts. Created parts are built using one or more other parts as the *parent parts*. The created parts are said to *depend on* the parent parts. If one or more of the parent parts change, all parts depending on those parent parts are automatically recalculated and redisplayed to reflect the change. As an example, consider the following case. A clipping plane is created through some 3D computational domain and a contour is created on the clipping plane. The contour's parent is the clipping plane, and the clipping plane's parent is the 3D domain. If the 3D domain is changed (e.g. the time step changes), the clipping plane will first be recalculated, followed by the contour. In this way, part coherence is maintained.

This article is divided into the following sections:

- [The Parts List](#)
- [Creating Parts](#)
- [Part Types](#)
- [Part Operations](#)
- [Part Attributes](#)
- [Where Parts Are Created and Maintained](#)
- [Hints and Tips](#)

The Parts List

Both model parts as well as all derived parts are displayed as items in the Parts List. There are several ways that the Parts list can be displayed, the default looks something like:

Case number (important when multiple datasets have been loaded) - Points to the 'Case 1' header in the list.

P indicates Parent of currently selected part - Points to the 'P' icon next to '1- Computational mesh'.

Part numbers - Points to the numbered list items: '1- Computational mesh', '2- Isosurface part', '3- Contour part', '4- Particle trace part', '5- Clip_plane', '6- Vector Arrow part'.

Part description - Points to the text of the selected part, '5- Clip_plane'.

Currently selected part - Points to the highlighted '5- Clip_plane' item.

Sort... button - Points to the 'Sort...' button at the bottom of the list.

The Sort... button gives you control over many other ways to display the parts in the Part list - including the order, whether parent child hierarchy is to be shown, and whether other details will be shown.

Sort... options:

- Alphabetical
- Chronological
- ID
- Show case
- Show parent/child tree
- Show abbreviated details
- Show table of details
- No details

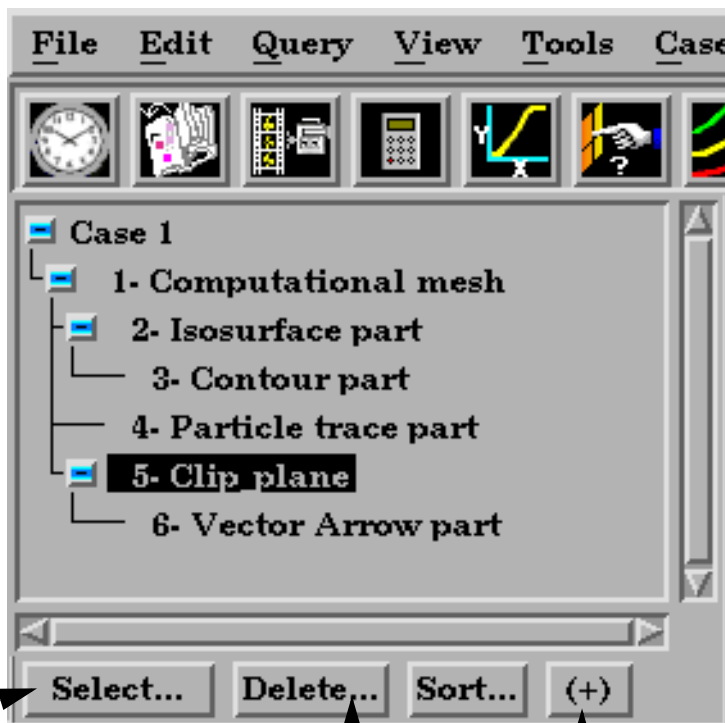

This shows the same part list as before, but using the parent/child tree - which quickly and efficiently shows the parent of each part.



There are several ways to easily select multiple parts.

Selected parts can be deleted here.....

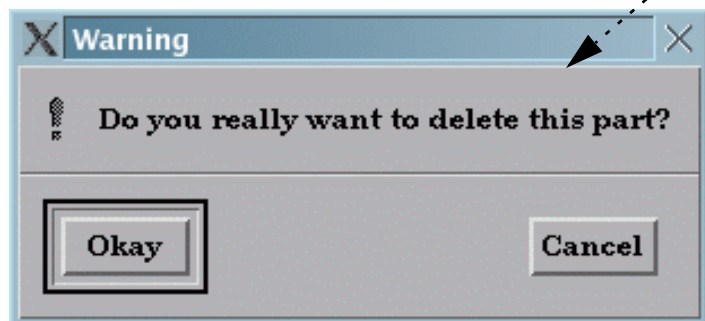

For models with many parts, the large part list can be used - which will expand the list down the left side of the desktop.....

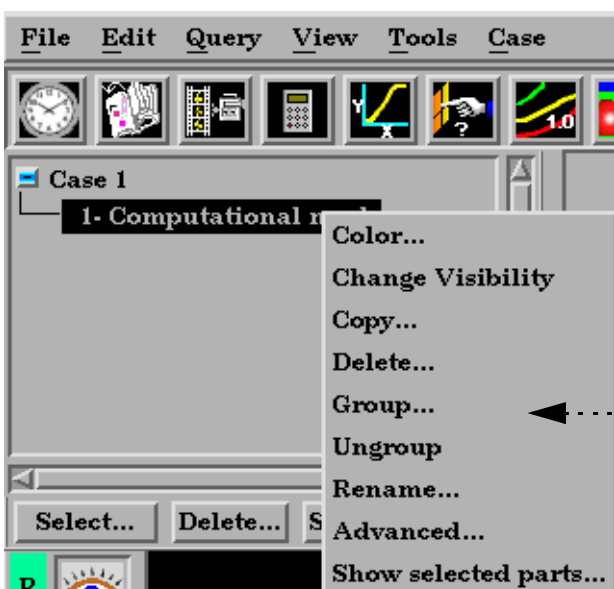
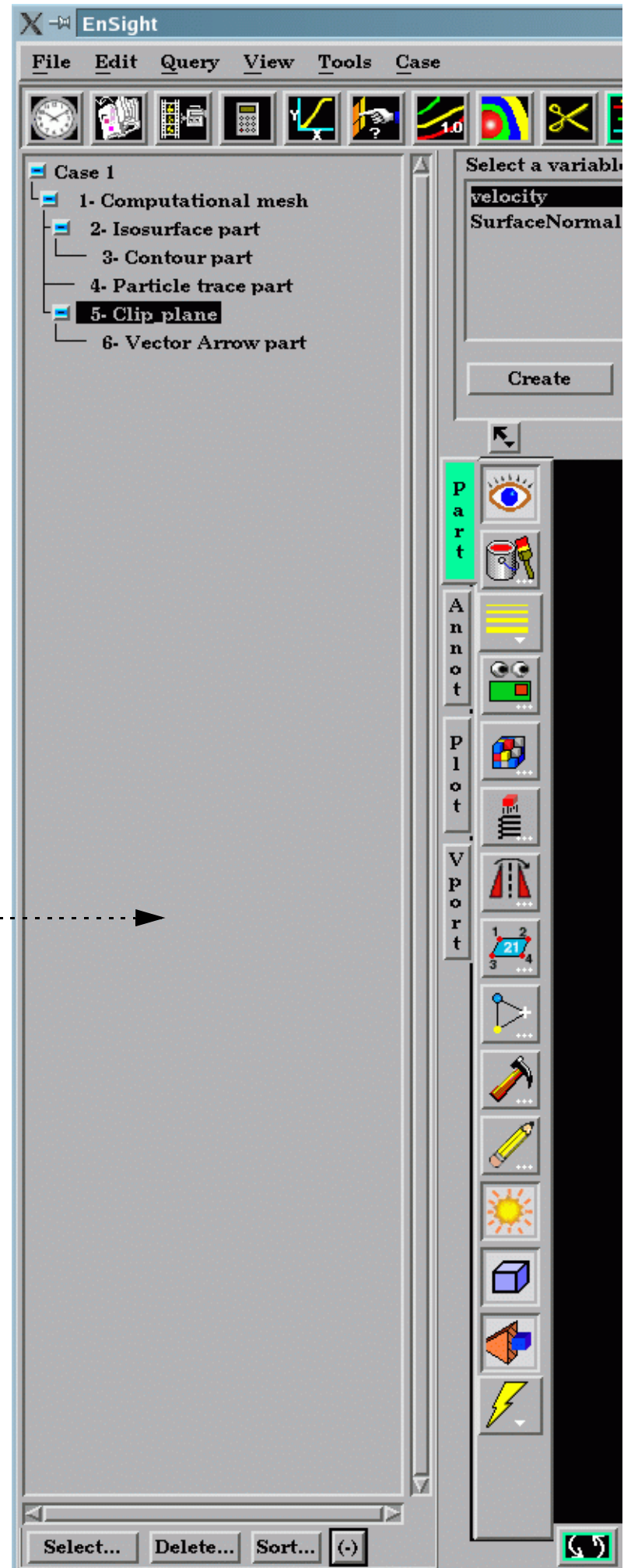

If you right click on a selected part (or parts) in the part list, you have access to a number of part operations

Also, Items in the Parts List are selected using standard Motif methods:

To ...	Do this ...	Details ...
Select an item	Select (or single-click)	Place the mouse pointer over the item and click the left mouse button. The item is highlighted to reflect the "selected" state.
Extend a contiguous selection	Select-drag	Place the mouse pointer over the first item. Click and hold the left mouse button as you drag over the remaining items to be selected. Only contiguous items may be selected in this fashion.
Extend a (possibly long) contiguous selection	Shift-click	Select the first item. Place the mouse pointer over the last item in the list to be selected. Press the shift key and click the left mouse button. This action will extend a selection to include all those items sequentially listed between the first selection and this one.
Extend a non-contiguous selection	Control-click	Place the mouse pointer over the item. Press the control key and click the left mouse button. This action will extend a selection by adding the new item, but not those in-between any previously selected items.
De-select an item	Control-click	Place the mouse pointer over the selected item. Press the control key and click the left mouse button. This action will de-select the item.
Open the Quick Interaction Area for a part	Double-click	Place the mouse pointer over the item and click the left mouse button twice in rapid succession.

Creating Parts

The mechanism for creating derived parts is largely the same regardless of part type:

1. In the Parts List, select the part(s) to use as parents.
2. Click the desired feature icon. This will open the corresponding creation section for the part type in the Quick Interaction area.
3. If necessary, select a variable to use from the Variables List (e.g. for contours or isosurfaces).
4. Set the desired creation attributes in the Quick Interaction area. **IMPORTANT:** if you change a text field, you *must* press return to have the change take effect!
5. Click the Create button in the Quick Interaction area.

The example below shows Isosurface part creation:

2. Click the isosurface creation icon.

4. Select an appropriate isovalue. (Often there is a sensible default)

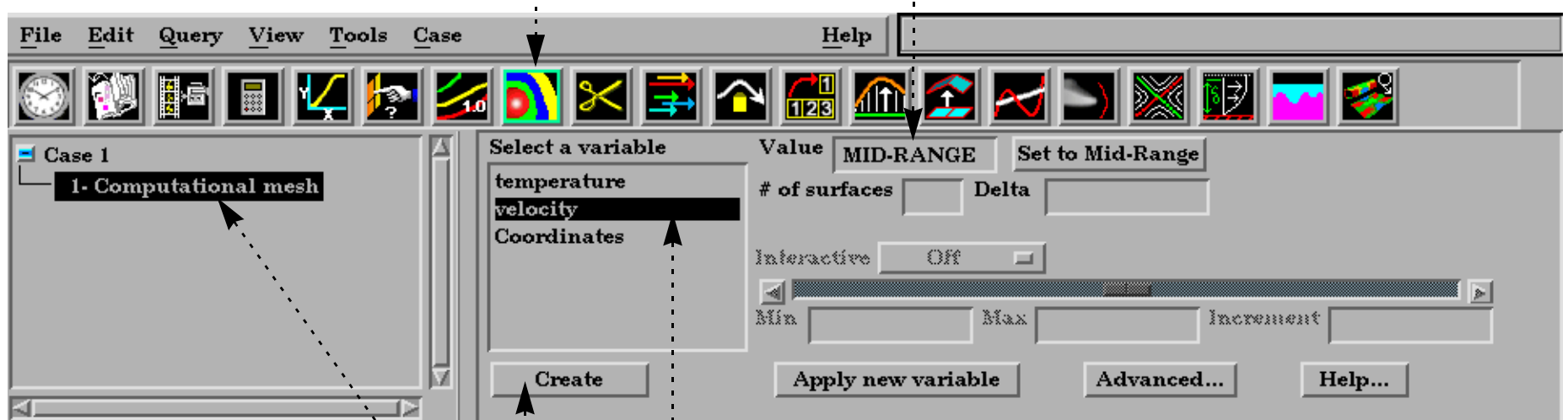

1. Select the parent part(s).

3. Select the variable to use.

5. Click "Create".

Part Types

The following table provides information on the available part types in EnSight:

Part Type	Symbol	Feature Icon	Description
<i>Clip</i>	2		A surface or line resulting from a clip of parts using an IJK, XYZ, or RTZ surface of the parts; or a clip of other parts using the Line, Plane, Box, Cylinder, Sphere, Cone, or Surface of Revolution tool; or a clip of other parts by revolving an existing 1D part.
<i>Contour</i>	C		Lines of constant value on 2D elements.
<i>Developed Surface</i>	D		A planar surface derived by unrolling a surface of revolution (e.g. unrolling a clip created with the Cylinder tool).
<i>Elevated Surface</i>	E		A part created by scaling a 2D part (in the direction of the local surface normal) based on the value of a variable.
<i>Isosurface</i>	I		A surface of constant value through 3D elements.
<i>Model</i>	M		An original part (i.e. loaded from a disk file) or created through some operation (e.g. copy or extract) on a model part.
<i>Particle Trace</i>	T		A part consisting of the paths taken by one or more massless particles as integrated through a vector (typically velocity) field.
<i>Profile</i>	P		Plot of a variable along a line (the 2D counterpart to an elevated surface).
<i>Vector Arrow</i>	V		A part consisting of a set of arrows showing direction and magnitude of a vector variable.
<i>Subset</i>	S		A part created by node and/or element label range(s) from model part(s).
<i>Tensor Glyph</i>	G		A part consisting of tensor glyphs showing direction and relative magnitude of the eigenvectors of a tensor variable.
<i>Material Part</i>	A		A part created according to the intersection of or domains of material values.
<i>Vortex Core</i>	X		A part consisting of line segments down the center of flow vortices.
<i>Shock Surface/Region</i>	K		A part consisting of the surface or volume elements where shock is higher than a threshold.
<i>Separation/Attachment Line</i>	L		A part consisting of line segments on a surface where flow separation and attachment is occurring.



Part Operations

EnSight provides several powerful part operators. These operations are accessible from the Edit > Part submenu.

Copy The copy operation creates a *dependent* copy of another part. The part is created on the client and is not known to the server. The new part has its own set of attributes (except for representation), but shares geometric and variable data with the original.

One of the best reasons to create a copy is to show multiple variables on one part at the same time in a side-by-side configuration. The copies can be moved independently since each new copy is automatically assigned a new **frame**.

See [How To Copy a Part](#) for more information.

Group This operation will collapse the selected parts into a new “umbrella” part. Grouping is most often used to combine a series of parts into a single part for ease in handling. The part is created on the client and is not known to the server. The operation is reversible through the Ungroup command.

See [How To Group Parts](#) for more information.

Delete The delete operation completely removes not only the currently selected parts, but also any parts derived from the selected parts.

See [How To Delete a Part](#) for more information.

Extract The extract operation is closely tied to part **representations**. Extract creates a new dependent part using only the geometry of the *current representation* of the part. For example, if the current representation of a part consisting of 3D elements is Border, the result of extraction will be a part consisting of all unshared 2D elements (the surface).

Extract is most often used to reduce the amount of information for a part (e.g. for faster display or for **geometry output**) or to create a surface shell part – perhaps for subsequent cutting – of a 3D computational domain.

See [How To Extract Part Representations](#) for more information.

Merge Merge creates one new dependent part from one or more selected parts. The original parts are unchanged. If only a single part is selected for the operation, merge will create a “true” copy of the part (as opposed to the “shallow” copy that the Copy operation creates).

Merging is most often used to combine a series of parts into a single part for ease in handling (such as attribute setting).

See [How To Merge Parts](#) for more information.

Part Attributes

All parts have numerous attributes that control behavior and display. Although many attributes can be controlled either through the Quick Interaction area or the Part Mode icons, complete access is provided by the various Feature Detail Editor dialogs. Part attributes and the Feature Detail editors are covered in detail in [How To Set Attributes](#).



Where Parts Are Created and Maintained

Part creation occurs on either the EnSight client or the server. Since the data that is available on the client and server are different, it is useful to understand where parts are created and where the data is stored. For example, you can only perform a query operation for parts that are stored on the server. The following table provides this information for each part type:

Part Type	Where Created	Data on Server?	Data on Client?
Clip	server	yes	depending on representation
Contour	client	no	yes
Developed Surface	server	yes	depending on representation
Discrete Particle	N/A	yes	depending on representation
Elevated Surface	server	yes	depending on representation
Isosurface	server	yes	depending on representation
Model	N/A	yes	depending on representation
Particle Trace	server	no	yes
Profile	client	no	yes
Vector Arrow	client	no	yes
Subset	server	yes	depending on representation
Tensor Glyph	client	no	yes
Vortex Core	server	yes	depending on representation
Shock Surface/Region	server	yes	depending on representation
Separation/Attachment Line	server	yes	depending on representation
Material	server	yes	depending on representation

In the last column, “depending on representation” means the current **visual representation** for the part. For example, if the part’s visual representation is “Not Loaded”, then no data is currently present on the client.

Hints and Tips

With some datasets that contain many parts, it sometimes becomes difficult to maintain the connection between a part as displayed in the Graphics Window and the corresponding item in the Parts List. To see which part(s) are currently selected in the Parts List, select View > Show Selected Parts... This will open a new graphics window (titled Part(s) Selected Viewport) that will display only those parts that are currently selected in the Parts List.

You can rapidly cycle through items in the Parts List using the up/down arrow keys on your keyboard. Select any item in the list and then press the up arrow (to move to previous entries) or down arrow (to move to subsequent entries). This is particularly helpful when used in conjunction with the Part(s) Selected Viewport window (as described above) to quickly locate a part of interest.

You can select parts in the Parts List by picking the part in the Graphics Window. In Part Mode, select Pick Part from the Pick pull-down. In the Graphics Window, place the mouse pointer over any portion of the desired part and press the ‘p’ key. If you hold down the control key at the same time, the part is added to the list of currently selected parts.

Selected parts can be written to disk and loaded in a future session. Select File > Save > Geometric Entities ... You have the option of saving either in EnSight format, VRML format, STL format, or other user-defined formats. See [How To Save Geometric Entities](#) for more information.

SEE ALSO

User Manual: [Features](#), [Part Operations](#)



Create Contours

INTRODUCTION

A contour is a line of constant value on a two-dimensional (though not necessarily planar) surface. The region on one side of the line is larger than the isovalue; the region on the other side is less than the isovalue. EnSight creates contour lines in groups where the isovalues either correspond to the levels in the palette defined for the contour variable, or a user specified range and distribution. The main level contour lines can also be labeled with the corresponding palette value.

BASIC OPERATION

2. Click the Contours icon.

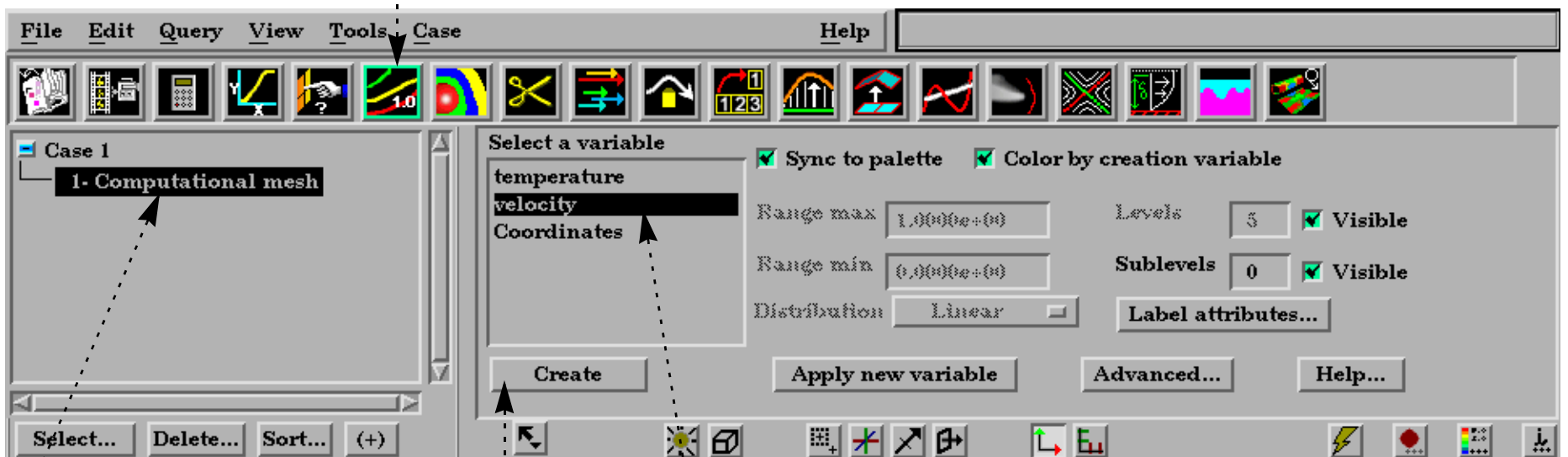

1. Select the parent part.

3. Select the variable to use.

4. Click Create.

The Contour Quick Interaction area lets you set the number of contour levels (and sublevels) as well as attach labels to the contour lines. Contour lines can be synced to the palette levels or can be chosen manually.

If you want the levels of the variable palette to be used for contours:

In the parts list, double-click the contour part you wish to edit.

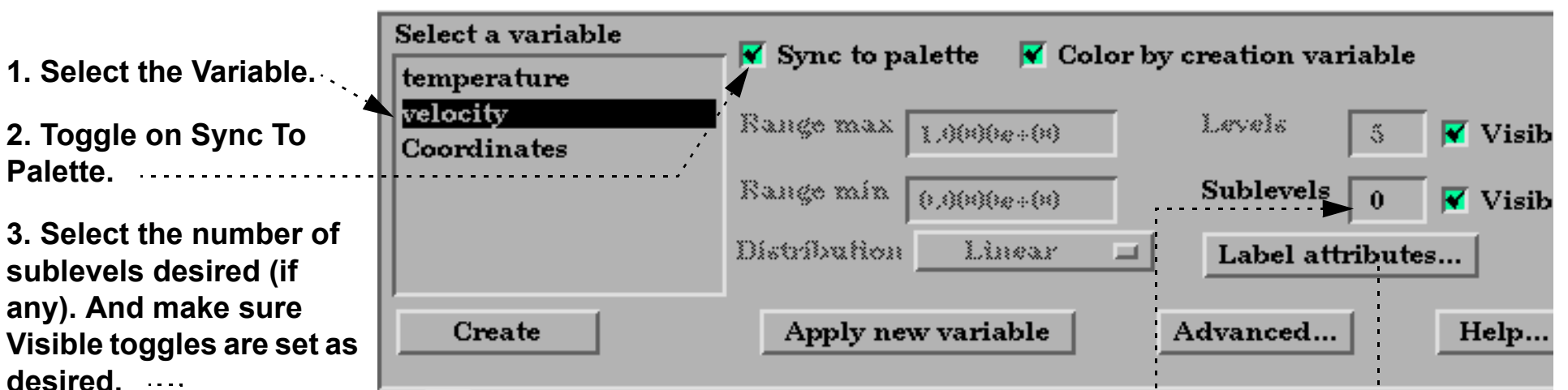

1. Select the Variable.

2. Toggle on Sync To Palette.

3. Select the number of sublevels desired (if any). And make sure Visible toggles are set as desired.

See [How To Edit Color Maps](#) for how to set the color palette levels.

4. Set the Visibility, Spacing, Color, and Format of the contour labels.

Note that only the main contour levels (not the sublevels) are labeled.

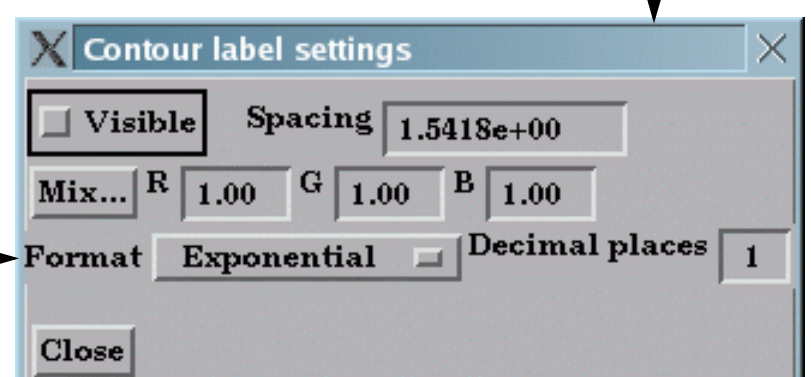



If you want contour levels to be independent of Variable palette levels:

In the parts list, double-click the contour part you wish to edit.

1. Select the Variable.

2. Toggle off Sync To Palette.

3. Specify the Min and Max Range.

4. Specify the number of Levels and sublevels.

5. Specify the Distribution method for the Range.

6. Set the Visibility, Spacing, Color, and Format of the contour labels.

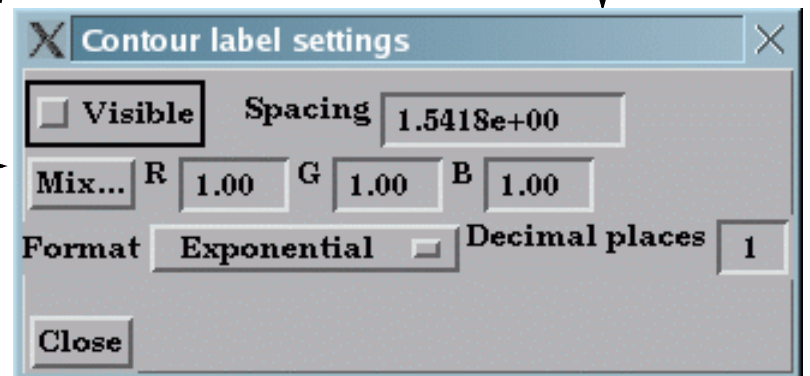
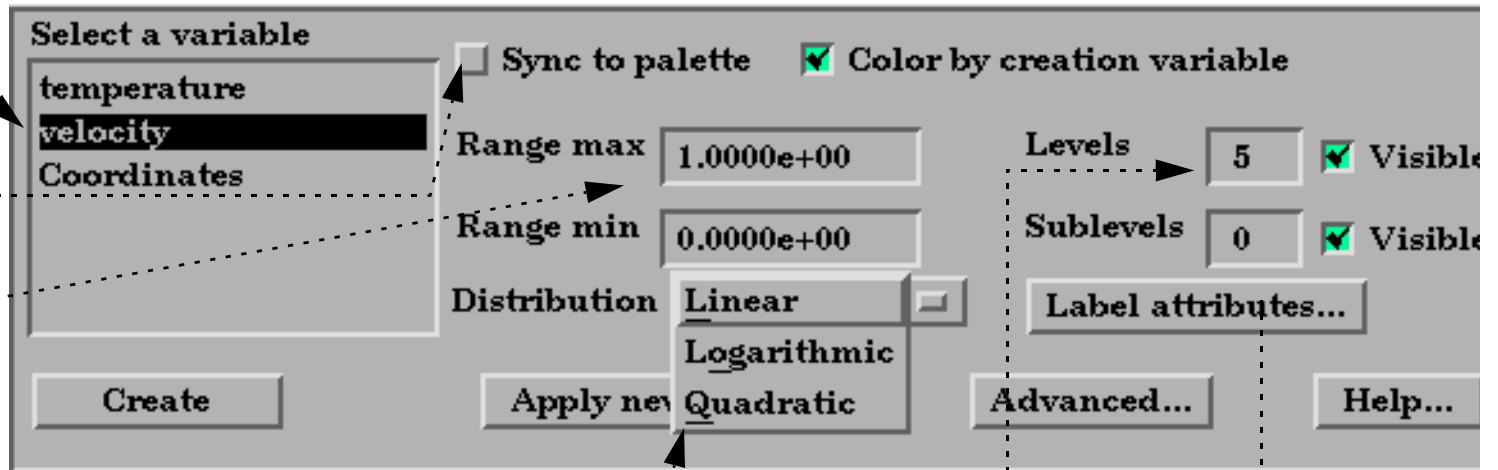

ADVANCED USAGE

When Sync To Palette is specified, the levels of the variable palette are used as the contour levels. You must edit the palette using the Feature Detail Editor for Variables to modify the number of levels, distribution, etc. See [How To Edit Color Maps](#) for guidance.

OTHER NOTES

The default behavior is to color the contour part by the creation variable. If you toggle this off, the contour part will not be colored by a variable automatically, but will be white.

Unlike most part creation operators, contours are created from the client's representation of the part – not the server's. If the parent part of the contour consists of one-dimensional elements or has no client-side visual representation at all, the resulting contour will be empty. This would be the case if the parent part was currently displayed as feature angle, border representation, or not loaded. The 3D border, 2D full representation is typically used for contour part parents. See [How to Change Visual Representation](#) for more information.

SEE ALSO

[Introduction to Part Creation](#), [How To Edit Color Maps](#).

User Manual: [Contour Create/Update](#)



Create Isosurfaces

INTRODUCTION

An isosurface is a surface of constant value in a three-dimensional field. It is the 3D counterpart to the contour loop: the region on one side of the isosurface has values greater than the isovalue; the region on the other side has values less than the isovalue. In EnSight, an isosurface can be generated from a scalar variable, a component or magnitude of a vector variable, or a component of the model coordinates.

An isosurface of a scalar or vector variable is typically a complex surface reflecting the distribution of the underlying variable. Isosurfaces of coordinates, however, are typically regular geometric shapes such as planes, cylinders, cones or spheres.

BASIC OPERATION

2. Click the Isosurface creation icon.

4. Select an appropriate isovalue. (the default will be a mid-range value)

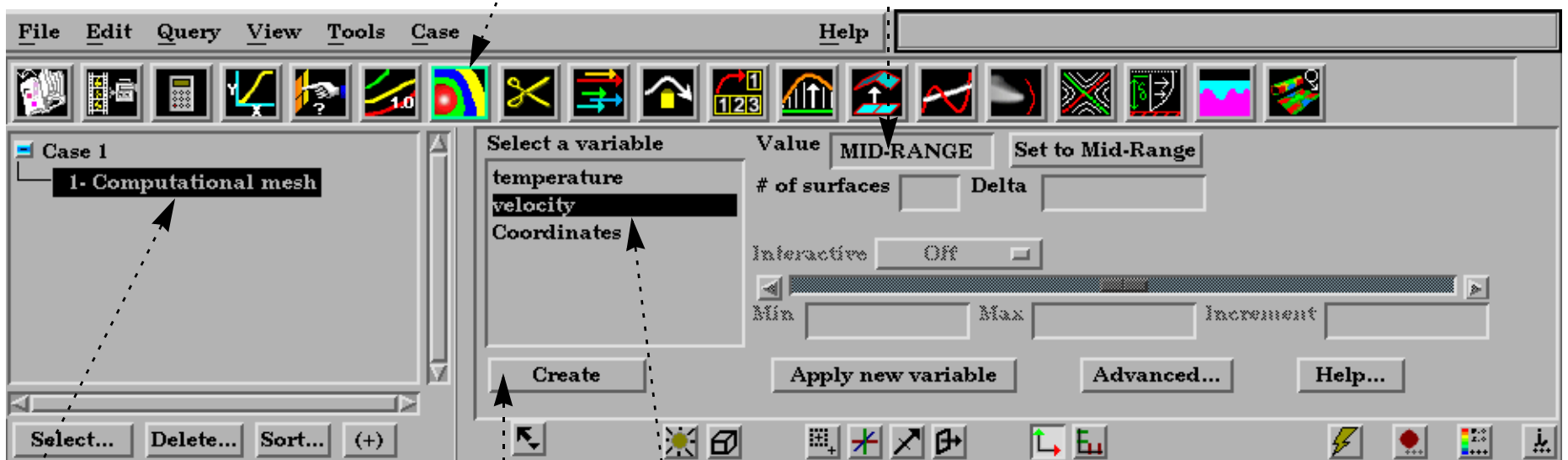

1. Select the parent part.

3. Select the variable to use.

5. Click Create.

ADVANCED USAGE

Interactive Isosurfaces

You can have EnSight automatically generate and display isosurfaces as you adjust a slider with the mouse.

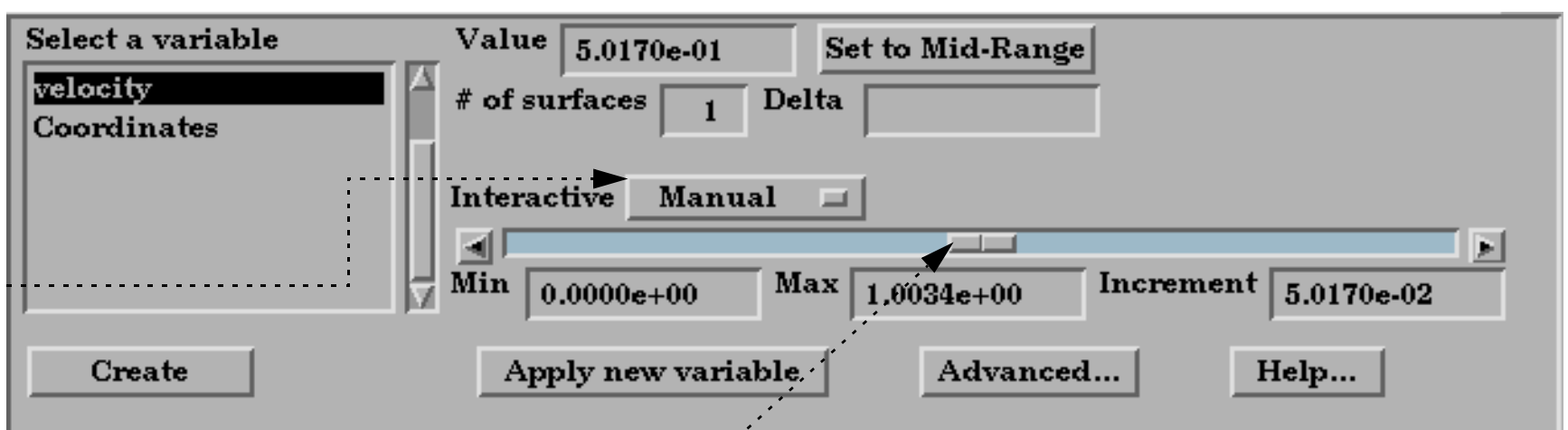

1. Set the Interactive mode to Manual.

2. Adjust the slider to the desired location.

You can also set the Interactive mode to Auto and EnSight will automatically sweep from Range Min to Max with step size equal to Increment.



Isosurface Animation

A range of isosurfaces can be automatically generated and viewed in a **flipbook**. Flipbooks provide on-screen animation of various dynamic events and (in the default setting) permit graphic manipulation (e.g. rotation or zoom) while the animation runs.

1. Open the Feature Detail Editor for isosurfaces (Edit > Part Detail Editors > Isosurfaces ...).

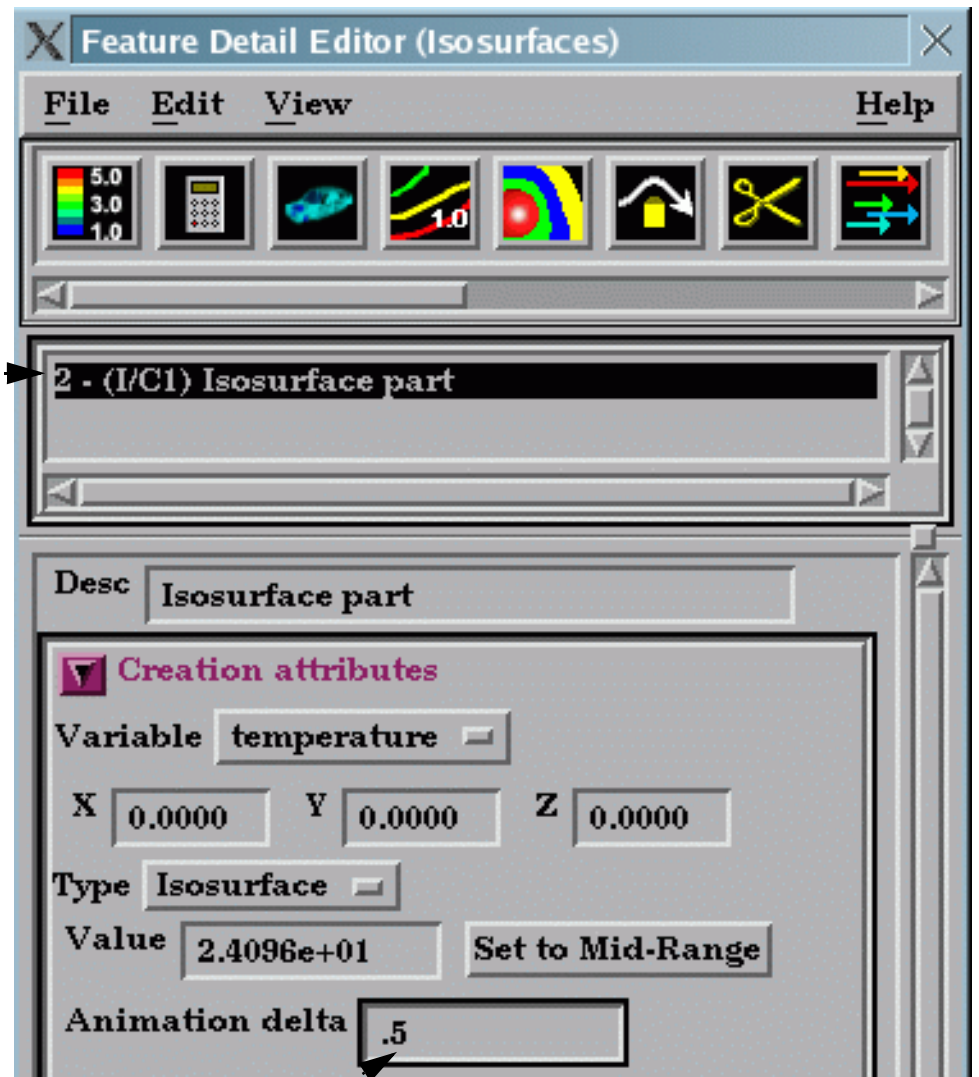

2. Select the isosurface part.

3. In the Creation Attributes section, set the Animation Delta to an appropriate value and hit return. For each page (frame) of the flipbook, this value will be added to the current value to yield the new isovalue.

4. Click the Flipbook icon.

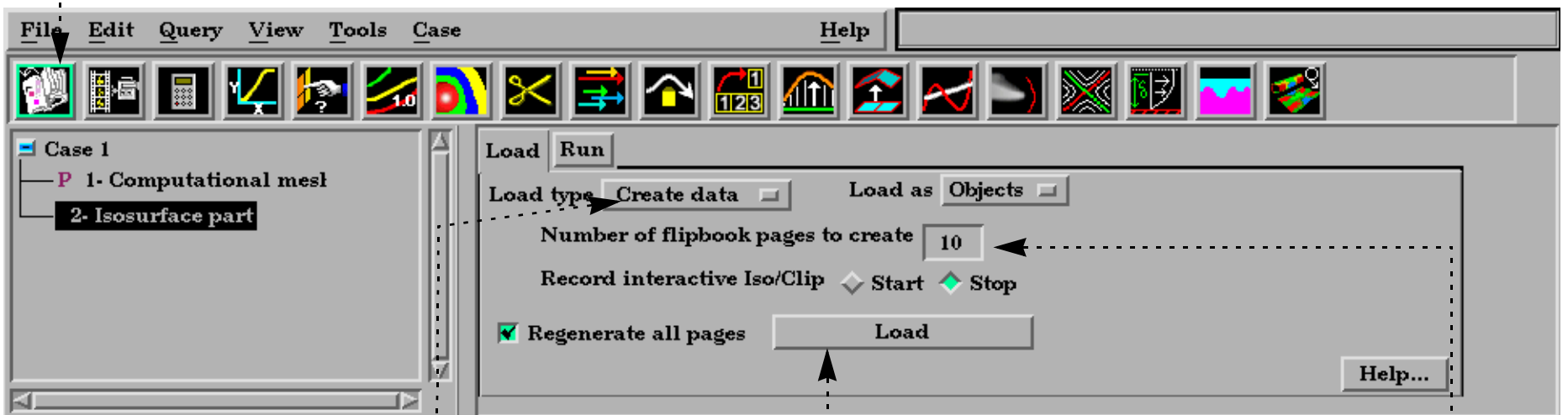

5. Set the Load Type to Create Data.

6. Set the number of pages to an appropriate value.

7. Click Load.

8. When loading is complete, the flipbook will begin to be displayed. You can then control the various run options under the Run tab.

EnSight can also automatically calculate a range of isosurfaces during **keyframe animation**.





Creating Multiple Offset Isosurfaces:

You can have EnSight create multiple isosurfaces at a specified delta value. The results is a group of isosurfaces:

2. Click the Isosurface creation icon.

4. Select an appropriate isovalue.
(the default will be a mid-range value)

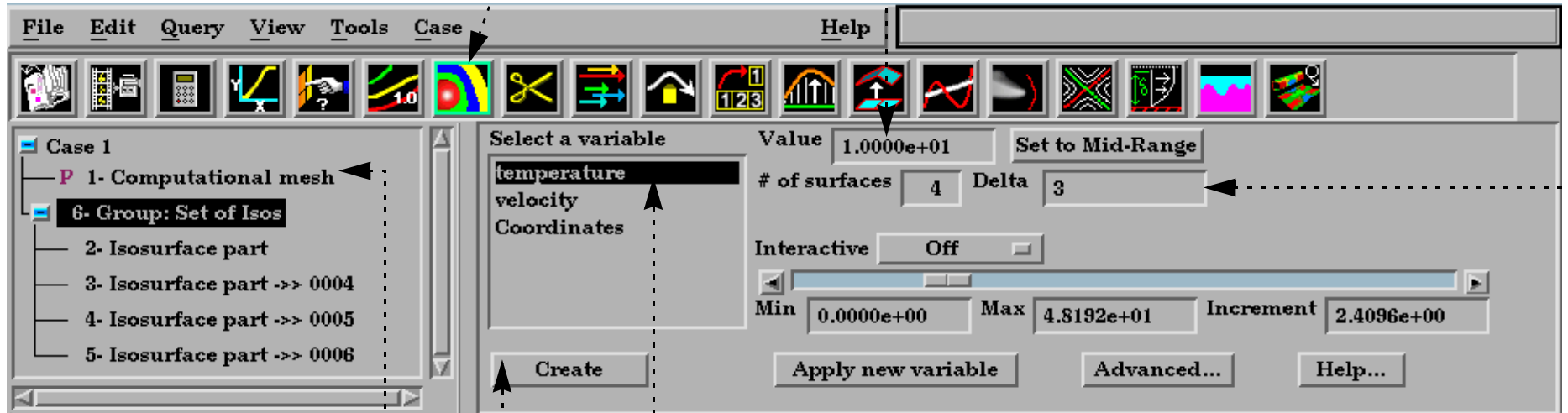

1. Select the parent part.

3. Select the variable to use.

5. Set the number of surfaces and the delta between them.

6. Click Create.

Isovolume Creation

An isovolume is a volume whose constituents (e.g. nodes and elements) are constrained to a constant interval range in a scalar field. In EnSight, you can constrain the isovolume to ranges less than an interval minimum, greater than an interval maximum, or between the interval minimum and maximum.

1. Open the Feature Detail Editor for isosurfaces (either: Edit > Part Detail Editors > Isosurfaces ..., or double click the Isosurface Feature Icon).

2. Select the isosurface part.

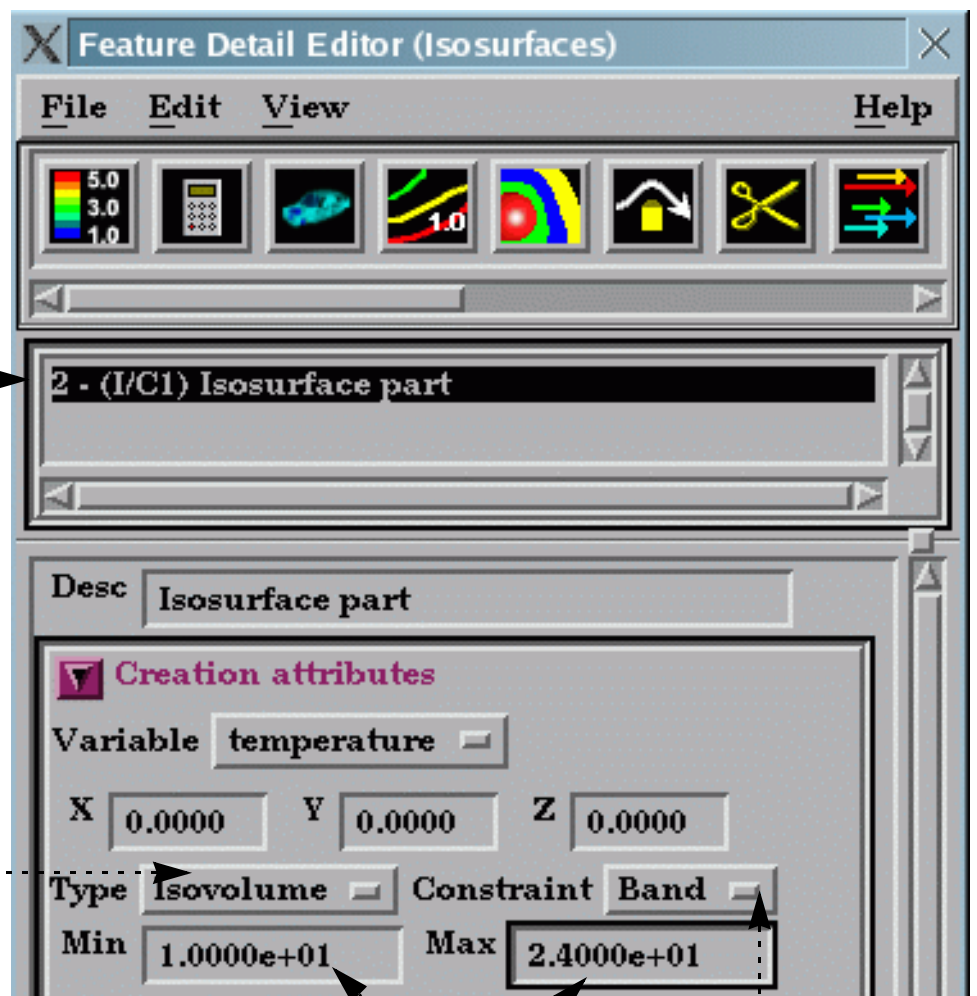

3. In the Creation Attributes section, set Type to Isovolume.

4. Set the Constraint to Band to constrain the isovolume within an appropriate Min and Max range of the scalar variable.



OTHER NOTES

Effective display of more than two nested isosurfaces is difficult. Set **transparency** on the outermost isosurface(s) to reveal the inner surfaces. To avoid confusion, don't try to display isosurfaces of more than one variable simultaneously, or multiple isosurfaces of the same variable colored by different variables.

SEE ALSO

[How-To Create a Flipbook Animation](#), [How-To Create a Keyframe Animation](#)

User Manual: [Isosurface Create/Update](#)





Create Particle Traces

INTRODUCTION

A particle trace represents the path a massless particle would take if released in a flow field. From an initial seed point (the *emitter*), a path is formed by integrating through the velocity field over time. The path is therefore everywhere parallel to the flow. Traces calculated in a steady-state flow field are called *streamlines*. For transient flow, the path is known as a *pathline*.

EnSight provides a great deal of control over emitter definition and trace appearance:

- Emitters can be defined using one of the built-in tools (Cursor, Line, or Plane) or by clicking on any surface in the Graphics Window. The nodes of an arbitrary part can be used as an emitter, or the emitter time and locations can be read from a file (see [EnSight Particle Emitter File Format](#) in the Chapter 11 of the User Manual).
- The streamline path can be generated in the positive, negative, or positive and negative time directions.
- Traces can be restricted to lie on any surface to search for flow topology and separation features.
- For transient cases, an emitter can have a delta time that controls the periodic release of additional particles into the dynamic flow.
- Emitters can be interactive: as you move the emitter with the mouse, the associated traces automatically recalculate and redisplay.
- Trace paths can be displayed as lines, ribbons, or as square tubes, where ribbon or tube twist follows the local flow rotation around the path.
- Particle traces can be easily **animated** to provide intuitive comprehension of the flow field. Complete control over all aspects of the animating tracers is provided, including length, speed, and release interval for multiple pulses.

BASIC OPERATION

To trace particles through a steady-state flow field:

2. Click the Particle Traces icon.

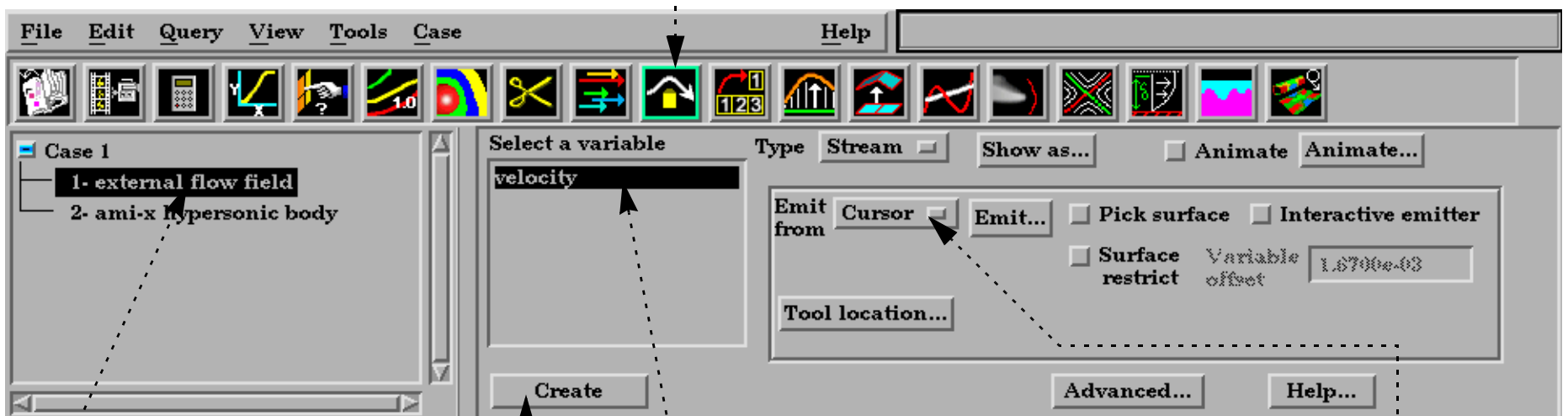

1. Select the flow field mesh part(s) to trace through.

3. Select the vector variable to use.

4. Select the desired emitter.

5. If the emitter is a tool (**Cursor, Line, Plane**), position the tool at the desired emitter location. You can also click the Tool Location button to precisely position the tool. If the chosen emitter is Part, then enter the part number in the Part ID field and press return.

6. Click Create. The particle traces will be created from the desired emitter. Their maximum time duration is controlled via the Total Time Limit found under Emit...



The following are the available Emit From options. Note that traces will only be generated for those emitter points that actually lie within an element of the selected flow field part(s).

Cursor	A single trace will be emitted from the Cursor tool.
Line	Multiple traces will be emitted from evenly spaced points along the Line tool. Enter the desired number of traces in the # Points field and press return.
Plane	Multiple traces will be emitted from evenly spaced points in a grid pattern over the Plane tool. Enter the desired number of traces in the X and Y direction (with respect to the Plane tool's axis) in the # Points X/Y fields and press return. The total number of traces will be the product of X and Y.
Part	One trace will be emitted from the number of nodes of the part you specify. This number of nodes will be randomly selected. Enter the number (from the Main Parts list) of the part you wish to use as an emitter, and the number of nodes.
File	Traces will be emitted from the locations, and at the times, specified in an EnSight Particle Emitter file. See EnSight Particle Emitter File Format in Chapter 11 of the User Manual.

The complete set of particle trace attributes can be edited in the Feature Detail Editor for Traces. However, some emitter attributes can be changed from the Particle Traces Quick Interaction area by clicking the Emit... button:

Click to set the trace direction:

- + : forwards in time (positive velocity direction) from the emission point(s)
- : backwards in time (negative velocity direction) from the emission point(s) towards the entering flow boundary
- +/- : both forwards and backwards

Toggle on to have start time be the current time, otherwise specify the start time.

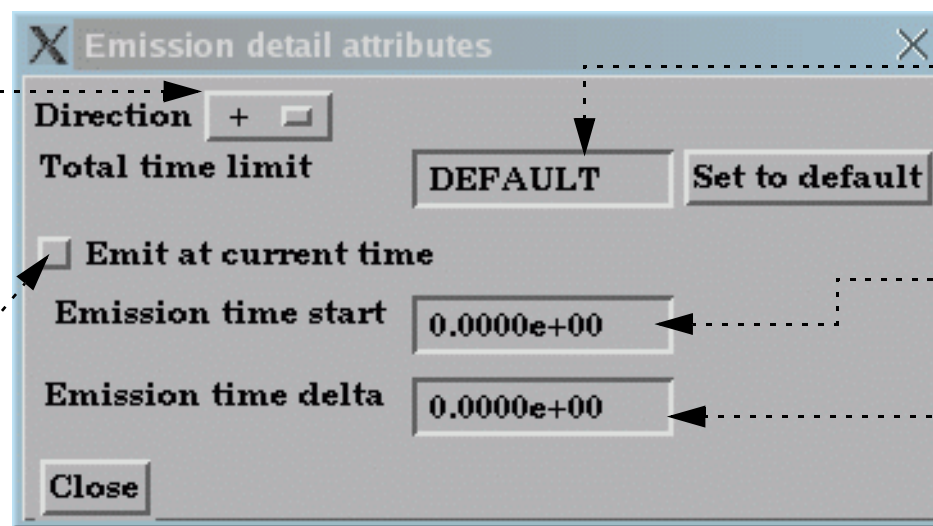

Set the total amount of time a trace will last (it may terminate for other reasons as well). An intelligent default will be set for you.

Solution time at which to begin pathline trace (pathlines only).

Delta emission time for pathlines. If not zero, a new set of traces will be emitted at S, S+D, S+2D, etc. into the changing flow field (where S is the Start time and D is the delta value). Used to create *streaklines* or *smoke traces*. Animated streaklines are one of the most powerful methods for visualizing transient flow.

Display Traces as Ribbons or Square Tubes, and control Arrowheads

Particle paths can be displayed as lines, ribbons, or square tubes, where ribbon or tube twist follows the local flow rotation. To enable ribbon or square tube display, and change trace arrowheads:

1. Double-click the desired particle trace part in the Main Parts list (to open the Quick Interaction area for the trace part).
2. Click Show As... to open the Trace Show As Attributes dialog.
3. Set Show As to Ribbon or Square Tubes.
4. If desired, change the default ribbon or square tube width and press return.
5. Select the Arrowhead representation desired. (Cone, Normal, or Triangles)
6. Set the number of arrowheads to display along a trace.
7. Set the arrowhead size.
5. Click Close.

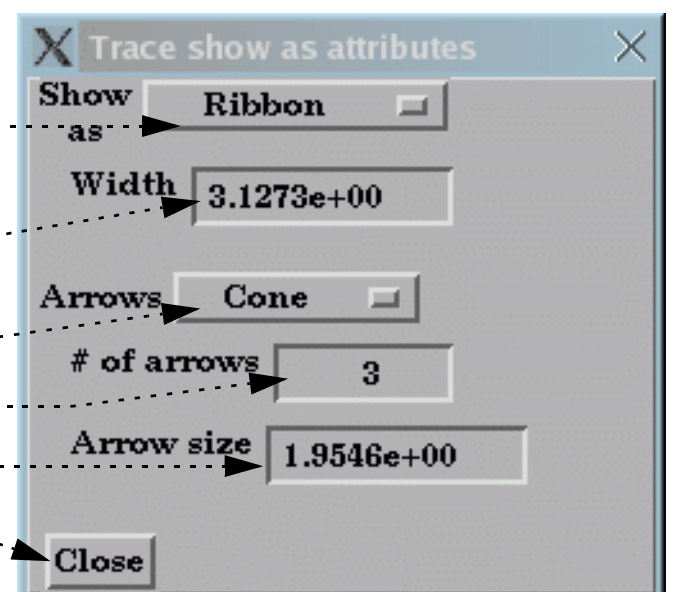



Animate Particles

Any type of particle trace can be animated. See [How To Animate Particle Traces](#) for more information.

Pick a Surface to Trace a Particle

Rather than emit from a tool or a part, you can also interactively pick points on a surface in the Graphics Window to define emitter locations. To do this:

1. Execute steps 1-3 as described under Basic Operation above.
2. Click the Pick Surface toggle.
3. Click Create.
4. Move the mouse into the Graphics Window and click the left mouse button when the cursor is over the desired location. The clicked point must be found within some element of the selected flow field mesh part to result in a trace.
5. You can click to create as many point emitters as you like. When done, move the mouse out of the Graphics Window.
6. Toggle off the Pick Surface button.

Note that you can also specify a rake (line) or net (plane) emitter by picking on a surface. Just set the emitter to Line or Plane prior to clicking Create. Then follow in the instructions in the pop-up window.

Interactive Particle Tracing

If a particle trace was created from one of the tool emitters (Cursor, Line, or Plane) and the trace is not a pathline trace, the emitter can be made interactive. When interactive, the tool that created the particle trace part can be moved with the mouse. As the tool is moved, new particle traces are automatically recalculated and redisplayed. To trace interactively:

1. Either create a particle trace part as described above (based on a tool) or double-click an existing particle trace part to open the Quick Interaction area for that part.
2. Toggle on Interactive Emitter. If the tool that originally defined the emitter is not visible, it will be turned on by this operation.
3. Move the mouse into the Graphics Window and manipulate the tool as desired. See the article on the applicable tool for information on tool manipulation ([Cursor](#), [Line](#), or [Plane](#)).
4. When done, toggle off Interactive Emitter.



Trace Surface-Restricted Particles

EnSight can trace particles such that they are constrained to lie on a (not necessarily planar) 2D surface – even if the velocity is zero at the surface. The trace is calculated by projecting a short distance off the surface into the 3D flow field and using the velocity value found there. Both the projection distance (variable offset) and a display offset are user definable.

Surface-restricted trace emitters are defined by mouse action in the Graphics Window. When you click and drag over the desired surface, the emitter is defined by projecting the mouse path onto the surface. To trace surface-restricted particle traces:

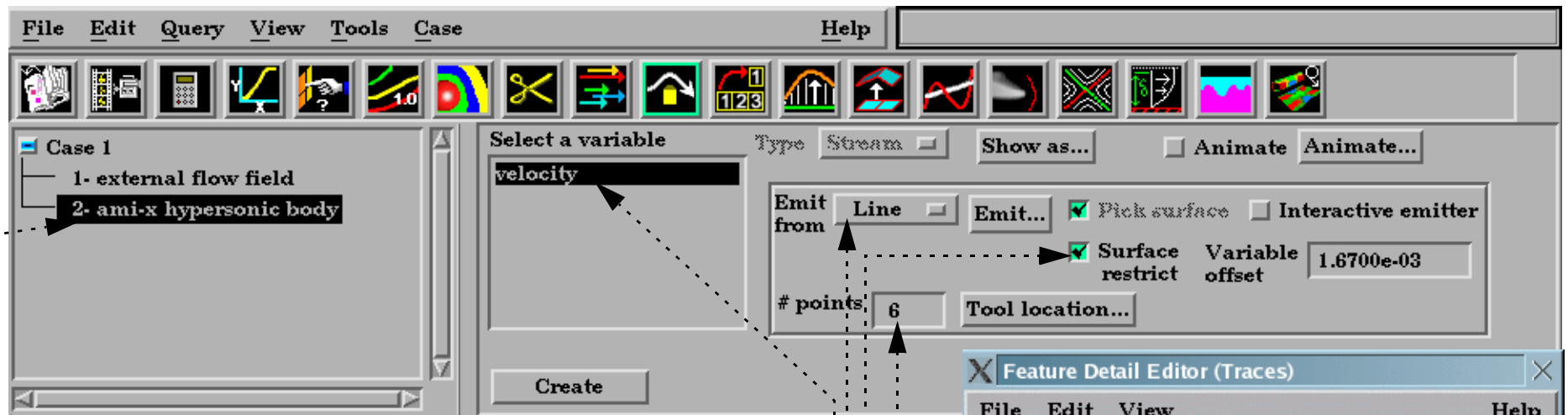

1. Select the desired surface part(s) in the Main Parts list. This should be the surface you wish to trace on.

2. Set the desired vector variable to use for tracing.

3. Select the desired emitter type (Cursor, Line, or Plane). Note that the applicable tool will not actually be used in this operation (a pick action will be used).

4. Toggle on the Surface Restricted button. Note that all subsequent tracing will be assumed to be surface restricted until this is toggled off.

5. If the Emit From is set to Line or Plane, enter the desired number of points (Line) or X and Y points (Plane).

9. Click the Create button.

10. Move the mouse pointer into the Graphics Window and:

for a Cursor emitter: click the left mouse button on the desired location.

for a Line emitter: click and hold the left mouse button on one endpoint of the desired line. Drag to the other endpoint (a white line will provide feedback).

for a Plane emitter: click and hold the left mouse button on one corner of the desired region. Drag to the opposite corner (a white rectangle will provide feedback).

11. You can continue to specify emitters of the selected type as long as the mouse pointer remains in the Graphics Window. When the pointer exits the window, the trace part will be created.

12. When done, toggle off Surface Restricted.

Note that this operation can also be done in the Feature Detail Editor for Traces.

In this dialog, you have control over the various other attributes of the trace - including variable offset, display offset, trace direction, etc.

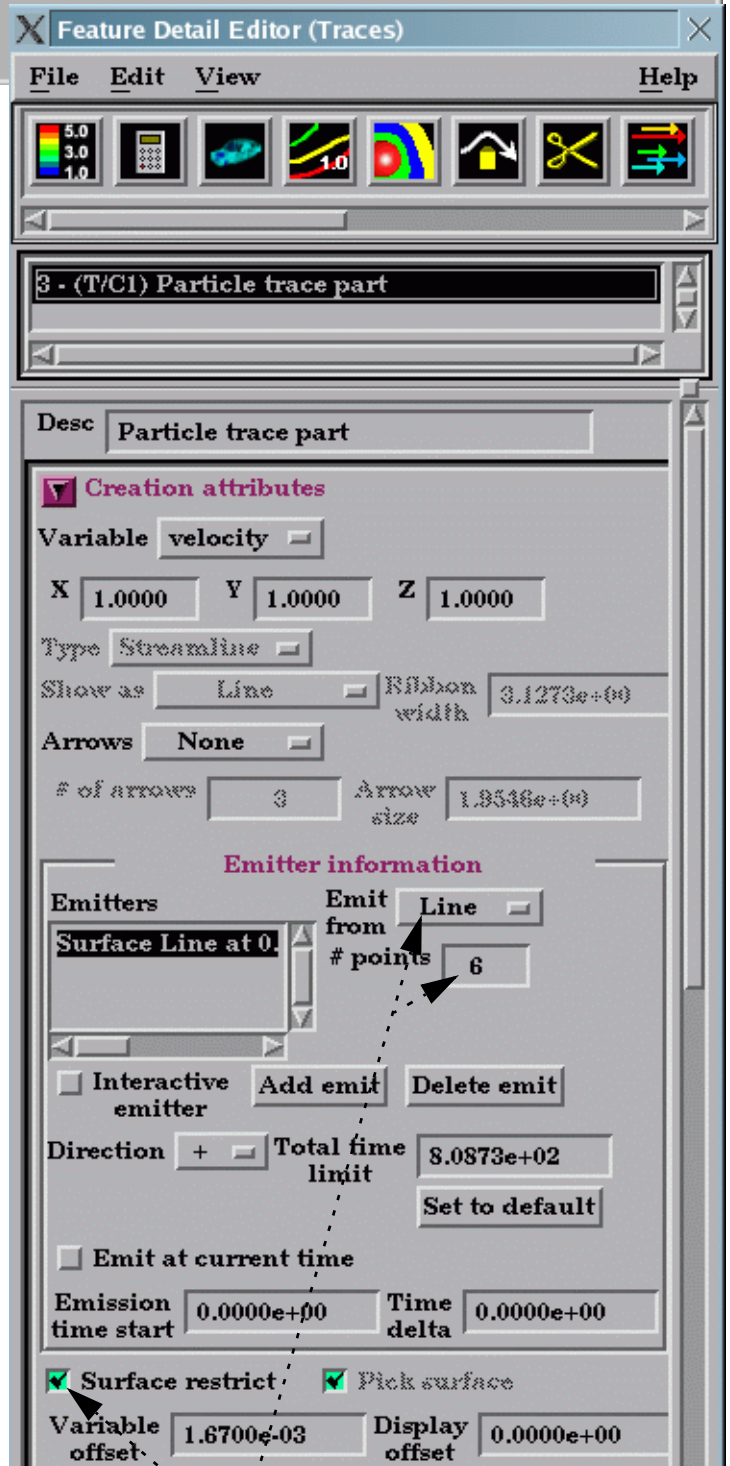



Trace Pathlines

EnSight provides complete control over transient particle tracing. Both the start time and the stop time can be specified. In addition, you can specify a delta value for an emitter that will cause additional particles to be emitted into the flow at regular intervals. This type of pathline is also called a *streakline* or *smoke trace*.

You create a pathline trace by setting the Type to Path (rather than Stream) prior to clicking Create. By default, the pathlines will start at the first time step of your simulation and terminate at the last step (unless stopped earlier). You can change these defaults with the Emission Detail Attributes dialog as described above (click Emit... to open).

Edit Emitter Attributes

Although the Particle Trace Quick Interaction area provides most tracing controls, the Feature Detail Editor for Traces provides complete control over all creation attributes. To use the editor:

1. Select **Edit > Part Feature Detail Editors > Particle Traces...** to open the **Feature Detail Editor (Traces)** dialog.
2. Select the desired particle trace part in the part list at the top of the dialog.

Creation attributes

- Variable:** VITESSE (Set the desired flow field variable)
- X:** 1.0000, **Y:** 1.0000, **Z:** 1.0000 (Set the fraction of each component of the vector variable to use in the trace calculation)
- Type:** Pathline (Trace type)
- Show as:** Line (Line or ribbon display), **Ribbon width:** 1.1717e+00 (Set ribbon width)
- Arrows:** None (Trace type)
- # of arrows:** 0 (Number of arrowheads along the trace), **Arrow size:** 7.3234e-01 (Set Arrowhead size)

Emitter information

- Emitters:** Line at 3.546926 4 (List of the emitters belonging to the selected trace part)
- Emit from:** Line (Emission tool for currently selected emitter)
- # points:** 10 (Number of points (If Line or Plane emitter))
- Interactive emitter:** (Set interactive emitter)
- Add emit:** (Add Emit: add a new emitter to the selected part based on the current attributes)
- Delete emit:** (Delete Emit: delete the selected emitter)
- Direction:** + (Set emitter direction, total time)
- Total time limit:** 1.6000e+02 (Set Total Time to the default)
- Set to default:** (Set Total Time to the default)
- Emit at current time:** (Set to emit at current time, or set emission time)
- Emission time start:** 1.0000e+00, **Time delta:** 0.0000e+00 (Set emission start and delta)
- Surface restrict:** (Toggle on Surface Restricted tracing)
- Pick surface:** (Toggle on surface picking for emitter definition)
- Variable offset:** 0.0000e+00, **Display offset:** 0.0000e+00 (Set surface restricted variable and display offsets)

Time step determination

Massed particle



Massed Particle Traces

EnSight also provides massed particle traces via the Feature Detail Editor for Traces.

1. Select **Edit > Part Feature Detail Editors > Particle Traces...** to open the Feature Detail Editor (Traces) dialog.
2. Select the desired the particle trace part in the part list at the top of the dialog.
3. Click the **Massed Particle** turn-down to reveal the massed particle parameters.
4. Modify the massed particle parameters according to your dataset. For instance, to compute only the drag force term in the momentum balance equation, toggle off the Gravity force term.
5. Toggle on **Massed Particles**.

The selected particle trace part will update to a massed particle trace(s) taking into consideration the drag force term parameters only.

For the theory used in massed particle traces, see the User Manual: [Particle Trace Create/Update](#)

OTHER NOTES

Particle trace calculation can be expensive for large or transient datasets and/or a large number of particles. Be careful when you initiate a trace operation – there is currently no way to abort it. If you are calculating pathlines, you should specify as many particles as possible at one time. Much of the pathline execution time is in reading the transient data from disk and this operation has to be performed regardless of how many traces were specified.

The EnSight particle trace algorithm integrates the vector flow field over time using a 4th-order Runge-Kutta method with a time varying integration step. Several of the integration parameters can be changed by the user. See [Particle Trace Create/Update](#) in the User Manual for more information.

If you have trace data for other types of particles (e.g. for multi-phase flow simulations) you can use the [discrete/measured data](#) facility to load the particle path positions and animate them over time.

SEE ALSO

[How To Animate Particle Traces](#)

User Manual: [Particle Trace Create/Update](#)



Create Clips

INTRODUCTION

EnSight provides a powerful set of clipping operators. See the following How To articles for more information:

Create Line Clips	Clip lines are linear clips through 2D or 3D models with samples taken at evenly spaced intervals (using the Line Tool). Values along a clip line can be visualized using profiles or queried and sent to a plotter .
Create Plane Clips	<p>A clipping plane is a planar slice through a 3D mesh using the Plane Tool. EnSight's clipping operation can take arbitrary cuts through either structured or unstructured meshes. The clip can be infinite in extent (at least to the bounds of the parts it is created from) or restricted to the bounds of the Plane tool. The nodes of the resulting clipping plane can be based on the topology and resolution of the underlying mesh or sampled on a regular grid.</p> <p>You can also create a clip that contains all the elements that intersect the plane value via the crinkly domain specification. These clips help view the integrity of the mesh at these values.</p>
Create Box Clips	A Box clip is a 3D volumetric hexahedral-shaped clip or cut. This clip uses the box tool (which can be manipulated anywhere in space), and the result can be the surface intersection of the box tool walls and the model, the volume portion of the model inside the tool, the volume portion of the model outside the tool, or the crinkly surface elements of the intersection. <i>Be aware that due to the algorithm used, this clip can (and most often does) have chamfered edges, the size of which depends on the coarseness of the model elements.</i>
Create Quadric Clips	<p>In addition to standard clipping planes, EnSight also provides clipping against quadric shapes. These clips use the corresponding quadric tool (Cylinder, Sphere, Cone, Surface of Revolution) to specify the location of the clip.</p> <p>You can also create a clip that contains all the elements that intersect the quadric value via the crinkly domain specification. These clips help view the integrity of the mesh at these values.</p>
Create IJK Clips	<p>An IJK clip is a 1D or 2D slice through a structured mesh. The resulting clip is a 1D line or 2D surface where one dimension (e.g. I) is held fixed while the other one or two dimensions (e.g. J and K) vary. The minimum and maximum range of the free dimensions can be set by the user, as well as the step size. IJK clips can be interactively animated throughout the range of the fixed dimension by manipulating a slider.</p> <p>Although planar clips can still be created through structured meshes, it is often preferable to create IJK clips since they are faster to calculate and use less memory. In addition, IJK clips are often more intuitive for the user (who typically built the mesh).</p>
Create XYZ Clips	<p>An XYZ clip is a 1D or 2D slice through a 2D or 3D mesh (structured or unstructured). The resulting clip is a 1D or 2D mesh slice where one of the dimensions (e.g. X) is held constant (or fixed) while the other two dimensions (e.g. Y and Z) vary in reference to the local frame of the mesh. XYZ clips can be interactively animated throughout the range of the fixed dimension by manipulating a slider. The minimum, maximum, and step size of the range of the fixed dimension can be set by the user.</p> <p>Although plane clips can still be created through meshes, it is often preferable to create XYZ clips since they are constrained to the local frame of the meshed part.</p> <p>You can also create a clip that contains all the elements that intersect the mesh slice value via the crinkly domain specification. These clips help view the integrity of the mesh at these values.</p>
Create RTZ Clips	An RTZ clip is a 1D or 2D slice through 2D or 3D meshes (structured or unstructured). The resulting clip is a 1D or 2D mesh slice where one of the dimensions (e.g. R, "radial component") is held constant (or fixed) while the other one or two dimensions (e.g. T, "theta component" and Z, "z axis component") vary in reference to the local frame of the mesh. RTZ clips can be interactively animated throughout the range of the fixed dimension by manipulating a slider. The minimum, maximum, and step size of the range of the interactive fixed dimension can be set by the user.
Revolution Tool Clips	A Revolution Tool clip can be made using the surface of revolution tool. It can be the surface created by the intersection of the surface of revolution tool and the model, the elements intersected by the surface of revolution tool (crinkly), or the volume of the inside and/or the outside domain swept by the revolution tool. This clip does not have interactive manipulation capability, with a slider or by dragging the tool with the mouse. However, the tool can be manipulated and the clip updated.
Revolve 1D Part Clips	A Revolution of 1D Part clip can be made using a 1D part and a user specified axis. It can be the surface created by the intersection of the 1D part about the axis and the model, the elements intersected by the 1D part about the axis (crinkly), or the volume of the inside and/or the outside domain swept by the 1D part about the axis. This clip does not have interactive manipulation capability, with a slider or by dragging the tool with the mouse. However, if the 1D part is capable of being moved, you can move it and the revolution clip will update.
Create General Quadric Clips	A general quadric clip $AX^2+BY^2+CZ^2+DXY+EYZ+FXZ+GX+HY+IZ=J$ can be created. This is only available from the Clip Feature Detail Editor.





Create Clip Lines

INTRODUCTION

In addition to standard clipping planes, EnSight also provides one dimensional clipping. Clip lines are linear clips through 2D or 3D models with samples taken at evenly spaced intervals. Values along a clip line can be visualized using [profiles](#) or queried and sent to a [plotter](#).

BASIC OPERATION

2. Click the Clip icon.

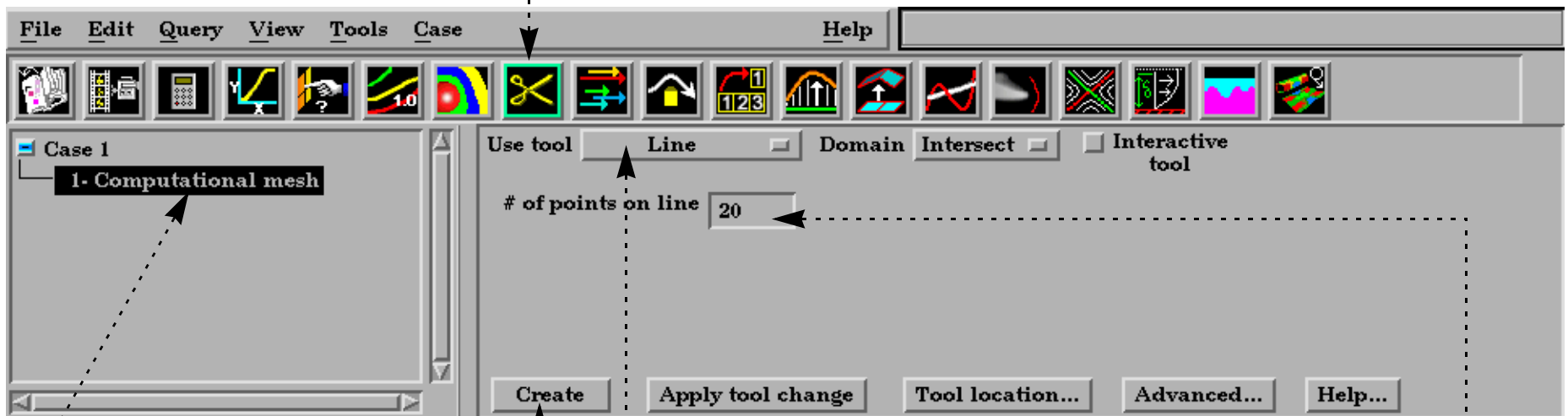

1. Select the parent part.

3. Select Line from the Use Tool pull-down.

4. Enter the desired number of samples on the line.

5. Position the Line tool as desired (see [How To Use the Line Tool](#)).

6. Click Create.

ADVANCED USAGE

Like the other clipping tools in EnSight, clip lines can be interactive: as you drag the Line tool with the mouse, the clip line is automatically recalculated and redisplayed. If a query has been created from the clip line, the plotted curve will automatically redisplay as well. To perform interactive line clips:

1. Double-click the desired clip line part in the parts list.

2. Toggle on Interactive Tool in the Quick Interaction area.

3. Move the mouse into the Graphics Window. Click on one of the Line tool hotspots (either endpoint or center cross) and drag the tool to the desired location.

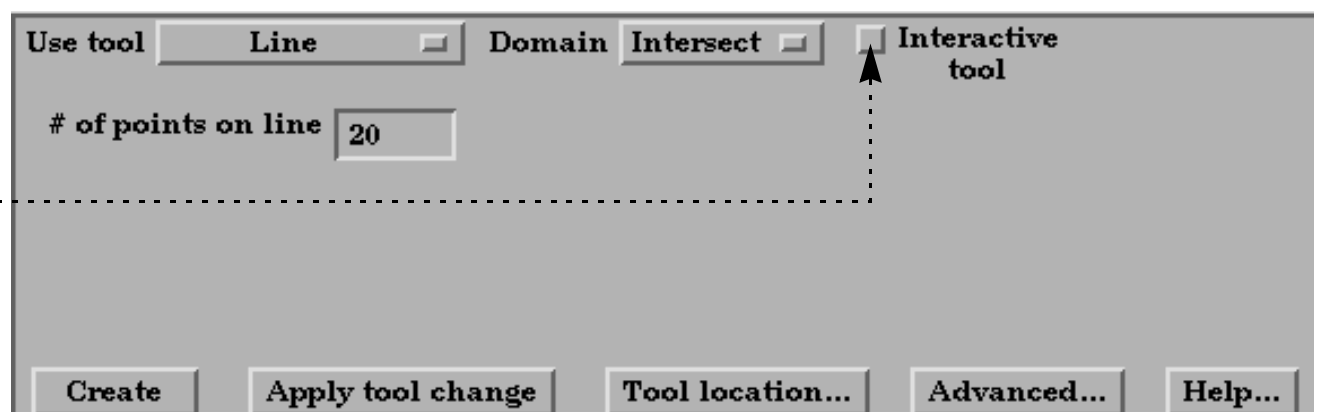



OTHER NOTES

It is sometimes useful to display just the nodes of a line clip. Using the Feature Detail Editor, you can change the display such that only nodes (not lines or elements) are displayed. The nodes can be shown as dots, crosses, or spheres. If displayed as crosses or spheres, the size (radius) can be constant or scaled by the value of a variable. See [How to Set Attributes](#) for more information.

SEE ALSO

[Introduction to Part Creation](#)
[How To Use the Line Tool](#)
[How to Create Profile Plots](#)
[How to Query/Plot.](#)

Other clips:

[How to Create Clip Planes](#)
[How to Create Quadric Clips](#)
[How to Create Box Clips](#)
[How to Create IJK Clips](#)
[How to Create XYZ Clips](#)
[How to Create RTZ Clips.](#)

User Manual: [Clip Create/Update](#)



Create Clip Planes

INTRODUCTION

A clipping plane is a planar slice through a 3D mesh. EnSight's clipping operation can take arbitrary cuts through either structured or unstructured meshes. The clip can be infinite in extent (at least to the bounds of the parts it is created from) or restricted to the bounds of the Plane tool. The nodes of the resulting clipping plane can be based on the topology and resolution of the underlying mesh or sampled on a regular grid.

Besides creating the intersection of a plane through a domain, which is the normal mode for clipping, a clipping plane can also be used to create parts which are what would result from a cut of its parent domain into "front" (inside) and or "back" (outside) parts. These parts contain valid elements of the same order as the original domain parts.

Like other clip tools, clipping planes can be interactively manipulated with the mouse providing a powerful volume visualization capability. Clipping planes can also be automatically animated to display results throughout a region of space or over time.

BASIC OPERATION

2. Click the Clip icon.....
3. Select Plane from the Use Tool pull-down.

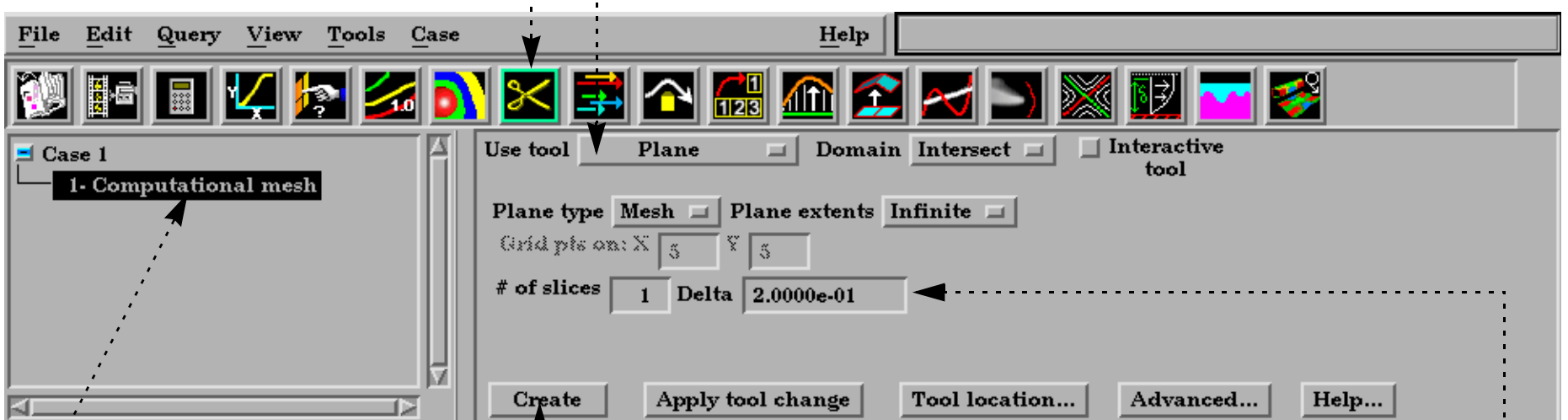

1. Select the parent part.
4. Position the Plane tool as desired (see [How To Use the Plane Tool](#)).
5. Click Create.

Note: Multiple plane clips with a delta in the normal direction can be created easily by setting these values.

ADVANCED USAGE

Interactive Clipping Planes

Like the other clipping tools in EnSight, intersection clip planes can be interactive: as you drag the Plane tool with the mouse, the clipping plane is automatically recalculated and redisplayed. To perform interactive plane clips:

1. Double-click the desired clip plane part in the parts list.

2. Toggle on Interactive Tool in the Quick Interaction area.

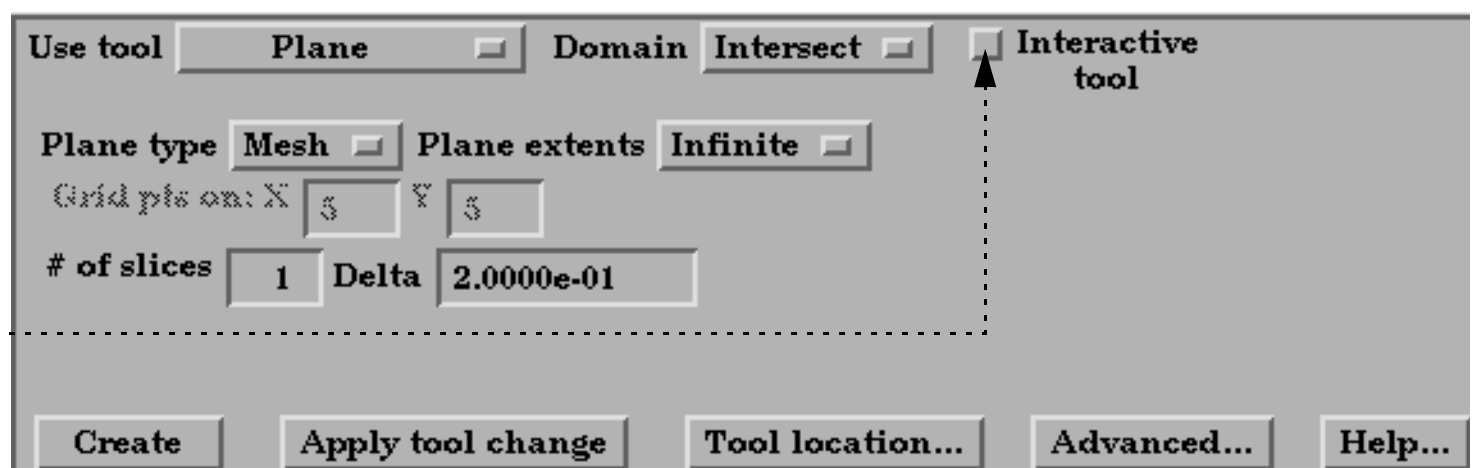

3. Move the mouse into the Graphics Window. Click on one of the Plane tool hotpoints (centerpoint or axis labels) and drag the tool to the desired location.





Grid Clips and Finite Clips

By default, clipping planes are calculated based on the resolution and topology of the underlying mesh (parent part(s)). Clipping planes can also be calculated using a regular sampling of the mesh. Such a clip is called a *grid clip* and is typically used for clipping unstructured meshes where element volumes vary widely. Creating vector arrows on a grid clip typically yields a more useful visualization than on a standard mesh clip.

By default, clipping planes extend to the bounds of the parent part. A clipping plane can also be restricted to the bounds of the Plane tool.

To change an existing clipping plane to a grid clip or to have finite extent:

1. Double-click the desired clipping plane part in the parts list.

2. To change to a grid clip, select Grid from the Plane Type pull-down.

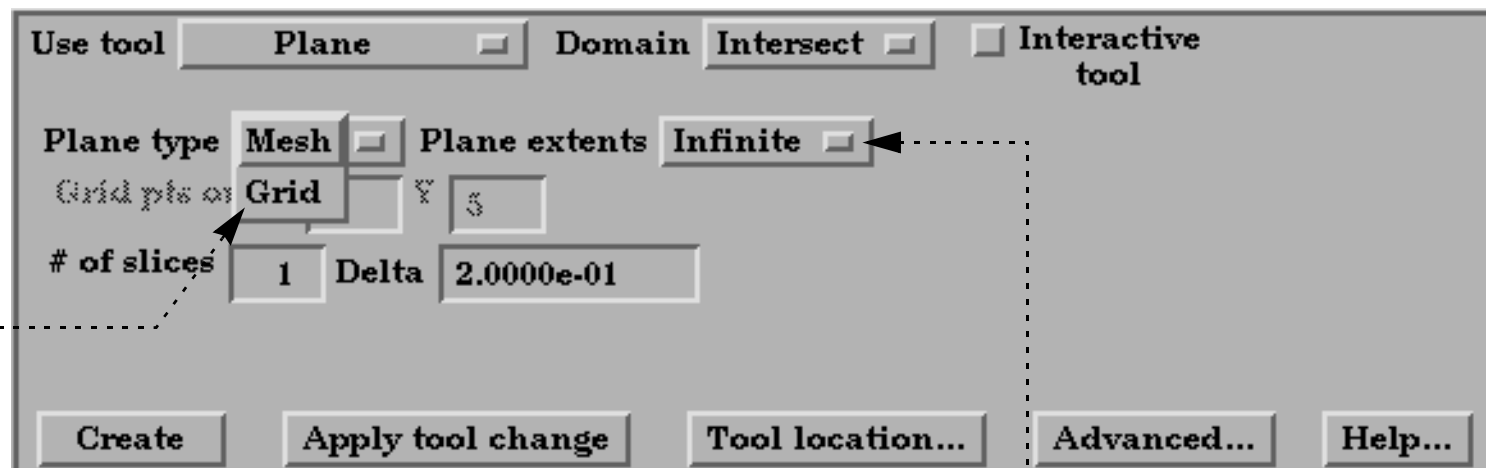

3. To change to a finite-extent clipping plane, select Finite from the Plane Extents pull-down.

Clipping Plane Animation

Although you can interactively sweep a clipping plane through a volume, it is sometimes desirable to have EnSight automatically calculate a series of clipping planes for you. These can then be replayed (as fast as your graphics hardware will permit) using EnSight's Flipbook Animation facility. The flipbook can animate a series of clipping planes using a starting and ending position for the Plane tool. You can also use the Keyframe Animation facility to animate clipping planes.

For a description of calculating a series of clipping planes with the Flipbook, see [How To Create a Flipbook Animation](#). For more information on keyframing, see [How to Create a Keyframe Animation](#).

Cutting with Planes

A plane can be used to create parts which are the result of a cut of its parent domain into "front" (inside) and or "back" (outside) parts. These parts contain valid elements of the same order as the original domain parts. Cutting can be used to slice away portions of a model that are not needed or to create animation effects such as "opening" closed regions to view the interior.

1. Select the desired parent parts in the parts list.

2. Click the Clip feature icon.

3. Select the Plane Tool.

4. Set the Domain to Inside, Outside, or In/Out (both inside and outside).

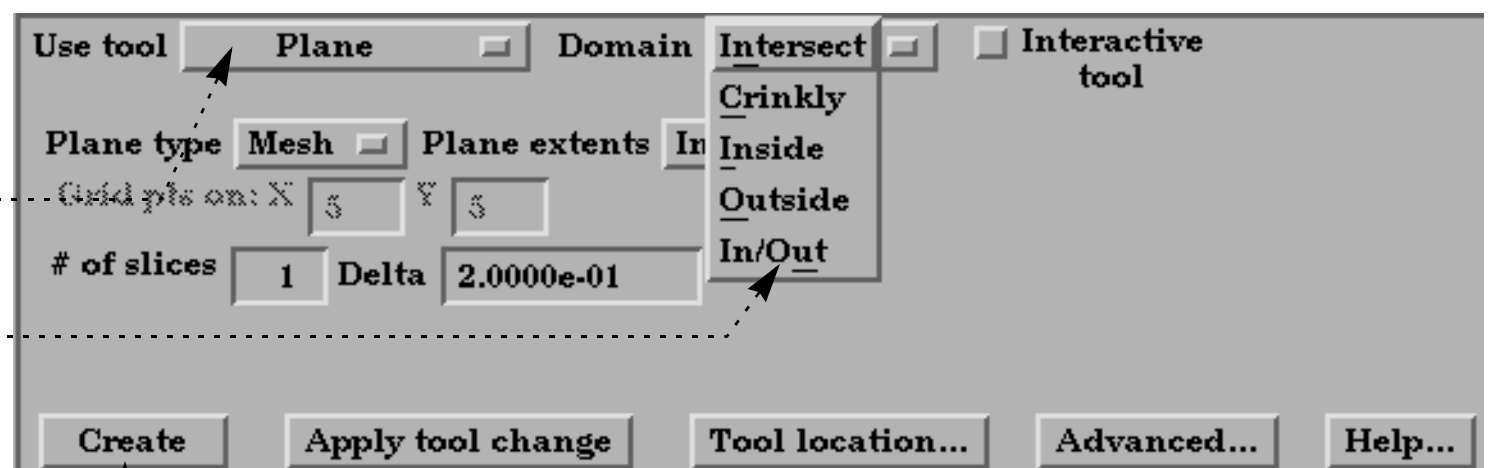

5. Hit the Create button.



Crinkly Plane Clips

You can also check the integrity of your mesh by clipping with a crinkly intersection. Specifying a Crinkly Domain results in a part composed of all the mesh elements that intersect the plane tool..

1. Change the Domain to Crinkly.

2. Click the Apply Tool Change button.

The screenshot shows the following settings:

- Use tool: Plane
- Domain: Intersect
- Interactive tool
- Plane type: Mesh
- Plane extents: In
- Grid pts on: X Y
- # of slices: Delta:
- Domain dropdown: Crinkly (selected), Inside, Outside, In/Out
- Buttons: Create, Apply tool change, Tool location..., Advanced..., Help...

OTHER NOTES

Use clipping planes to create planar clips through arbitrary meshes. If you have a structured mesh (such as those in PLOT3D format), you may wish to use IJK clips instead. An IJK clip displays a “plane” of constant I, J, or K. An interactive IJK clip will sweep through the range of (for example) I displaying the JK plane at each I value. See [How to Create IJK Clips](#) for more information.

SEE ALSO

[Introduction to Part Creation](#)
[How To Use the Plane Tool](#)
[How To Create a Flipbook Animation.](#)

Other clips:

[How To Create Clip Lines](#)
[How To Create IJK Clips](#)
[How To Create Quadric Clips](#)
[How To Create XYZ Clips](#)
[How To Create RTZ Clips](#)
[How To Create Box Clips.](#)

User Manual: [Clip Create/Update](#)



Create Box Clips

INTRODUCTION

A Box clip is a 3D volumetric hexahedral-shaped clip or cut. This clip uses the box tool (which can be manipulated anywhere in space), and the result can be the surface intersection of the box tool walls and the model, the volume portion of the model inside the tool, the volume portion of the model outside the tool, or the crinkly surface elements of the intersection.

*Be aware that due to the algorithm used, this clip can (and most often does) have **chamfered edges**, the size of which depends on the coarseness of the model elements.*

BASIC OPERATION

1. Select the parent part

2. Click the Clip Icon

3. Select Box Tool

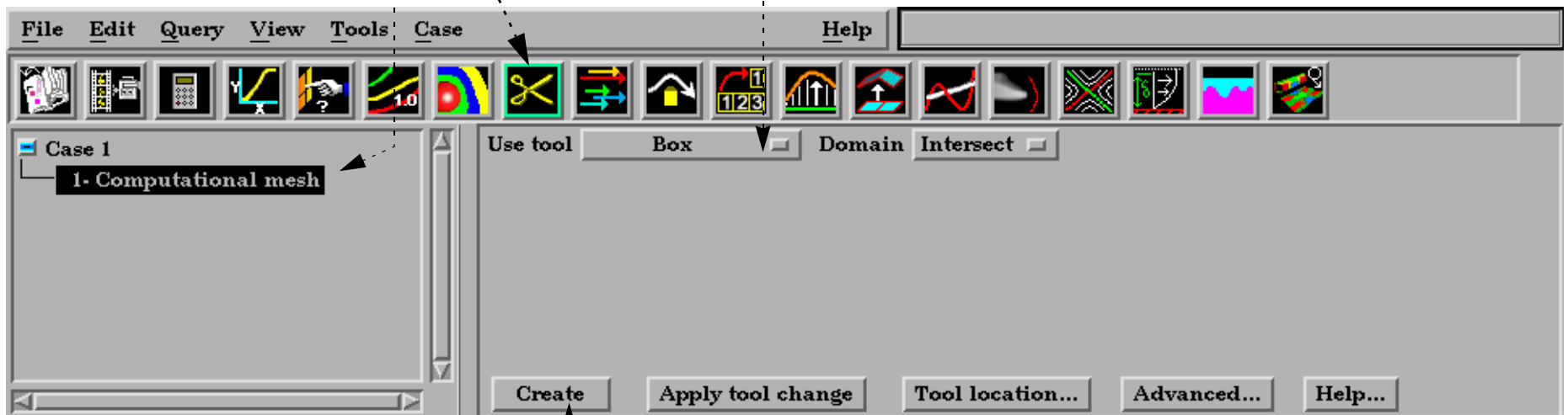

4. Position the Box Tool as desired.

5. Click Create

SEE ALSO

[Introduction to Part Creation](#)
[How To Use Box Tool](#)

Other clips:

[How to Create Clip Lines](#)
[How to Create Clip Planes](#)
[How to Create Quadric Clips](#)
[How to Create IJK Clips](#)
[How to Create XYZ Clips](#)
[How to Create RTZ Clips.](#)

User Manual: [Clip Create/Update](#)



INTRODUCTION

In addition to standard clipping planes, EnSight also provides clipping against quadric shapes. These clips use the corresponding quadric tool **Cylinder**, **Sphere**, **Cone**, **Surface of Revolution**) to specify the location of the clip.

As with clip planes, these tools can also be used to perform cut operations, creating parts which are the “inside” or “outside” of the parent domain.

As with intersection clip planes, quadric clips can be changed interactively by manipulating the corresponding tool with the mouse.

BASIC OPERATION

2. Click the Clip icon.

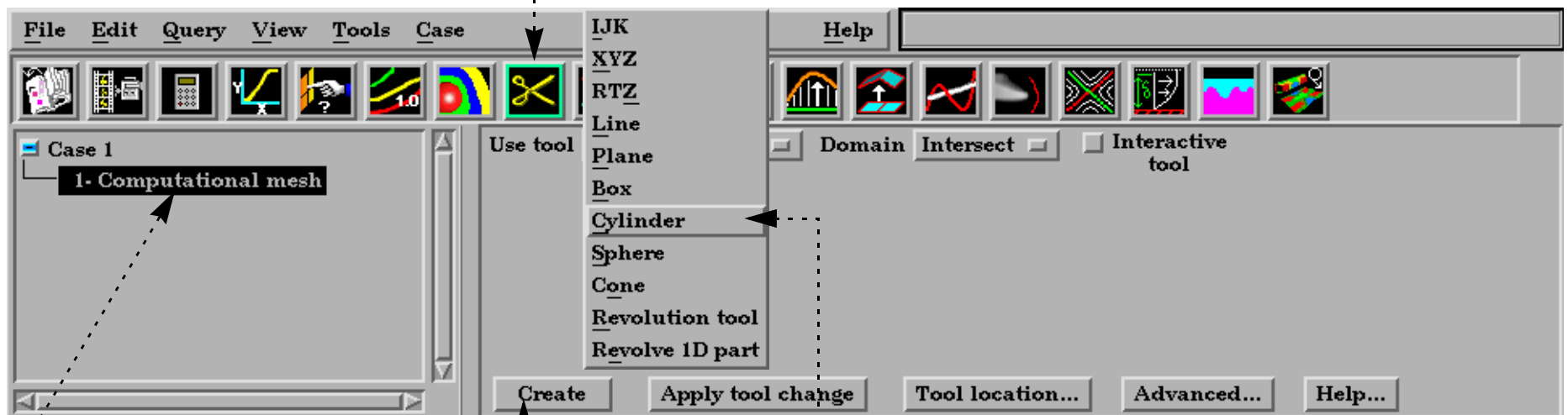

1. Select the parent part.

3. Select the desired quadric tool from the Use Tool pulldown.

4. Position the tool as desired (see the How to for the applicable tool).

5. Click Create.

ADVANCED USAGE

Like the other clipping tools in EnSight, intersection quadric clips (except those created with the revolution tool) can be interactive: as you drag the applicable tool with the mouse, the clip is automatically recalculated and redisplayed. To perform interactive quadric clips:

1. Double-click the desired quadric clip part in the parts list.

2. Toggle on Interactive Tool in the Quick Interaction area.

3. Move the mouse into the Graphics Window. Click on one of the tool hotspots (see the How to for the applicable tool) and drag the tool to the desired location.

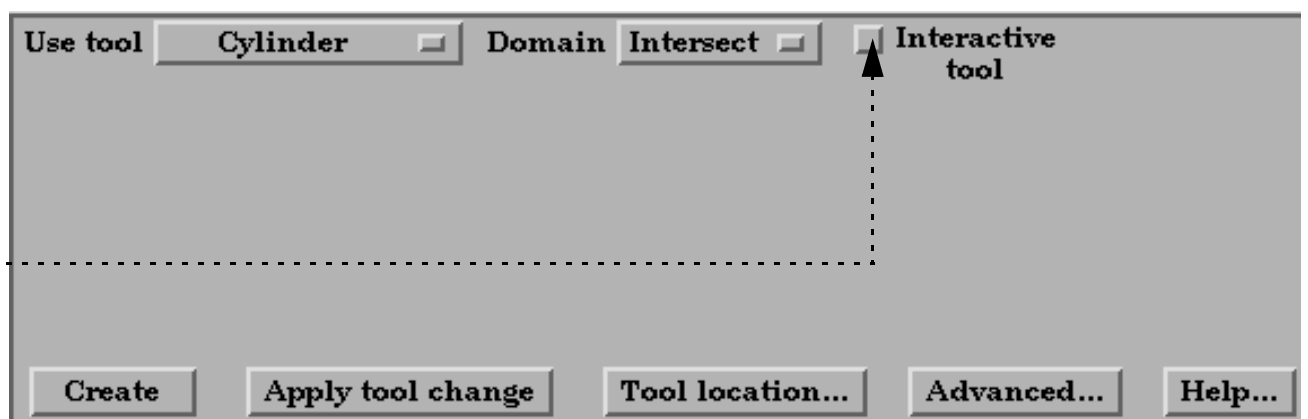



Cutting with Quadric Tools

A quadric tool can be used to create parts which are the result of a cut of its parent domain into “inside” and or “outside” parts. These parts contain valid elements of the same order as the original domain parts.

1. Select the desired parent parts in the parts list.
2. Click the Clip feature icon.
3. Select the desired Quadric Tool.
4. Set the Domain to Inside, Outside, or In/Out (both inside and outside).
5. Hit the Create button.

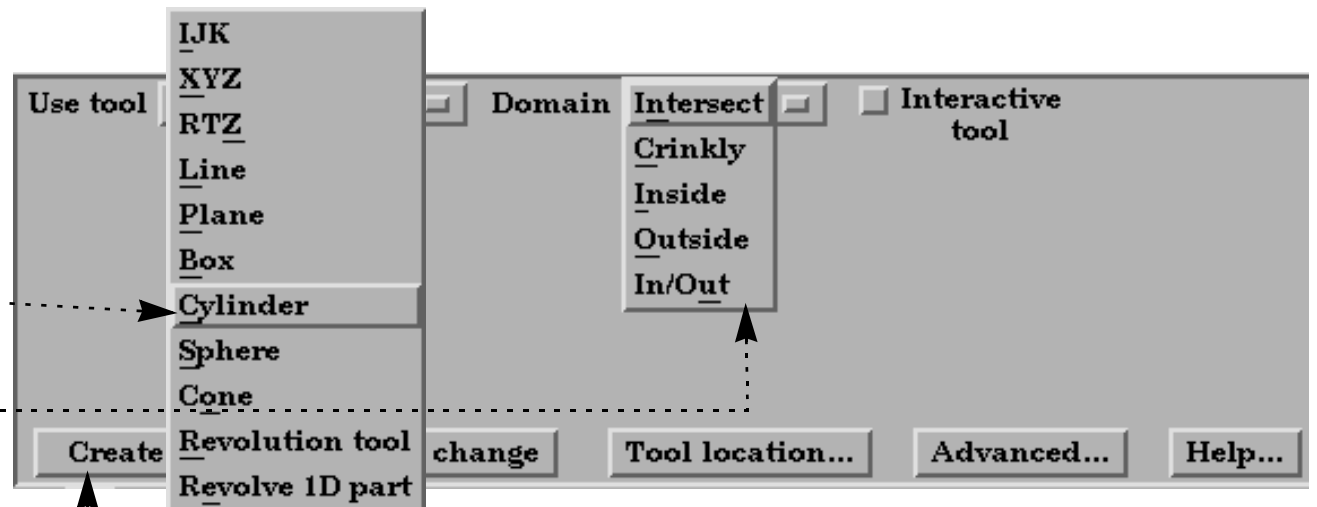

Crinkly Quadric Clips

You can check the integrity of your mesh by clipping with a crinkly intersection. Specifying a Crinkly Domain results in a part composed of all the elements of the mesh that intersect the quadric tool.

4. Change the Domain to Crinkly.
5. Click the Apply Tool Change button.

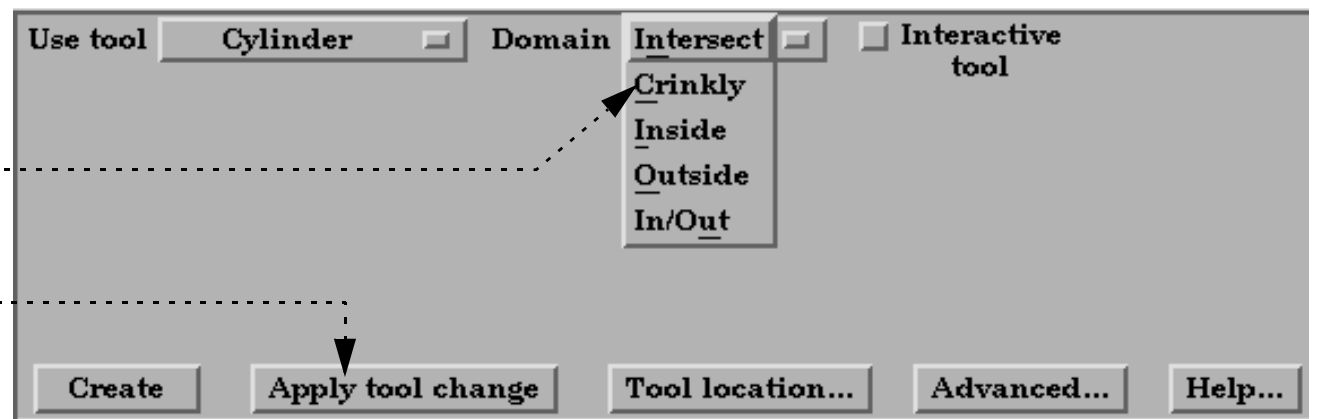

SEE ALSO

[Introduction to Part Creation](#)

How To Use the {[Cylinder](#), [Sphere](#), [Cone](#), [Surface of Revolution](#)} Tool.

Other clips:

- [How to Create Clip Planes](#)
- [How to Create Clip Lines](#)
- [How to Create IJK Clips](#)
- [How to Create XYZ Clips](#)
- [How to Create RTZ Clips](#)
- [How to Create Box Clips.](#)

User Manual: [Clip Create/Update](#)



Create IJK Clips

INTRODUCTION

An IJK clip is a 1D or 2D slice through a structured mesh. The resulting clip is a 1D line or 2D surface where one dimension (e.g. I) is held fixed while the other one or two dimensions (e.g. J and K) vary. The minimum and maximum range of the free dimensions can be set by the user, as well as the step size. IJK clips can be animated throughout the range of the fixed dimension by manipulating a slider.

Although planar clips can still be created through structured meshes, it is often preferable to create IJK clips since they are faster to calculate and use less memory. In addition, IJK clips are often more intuitive for the user (who typically built the mesh).

BASIC OPERATION

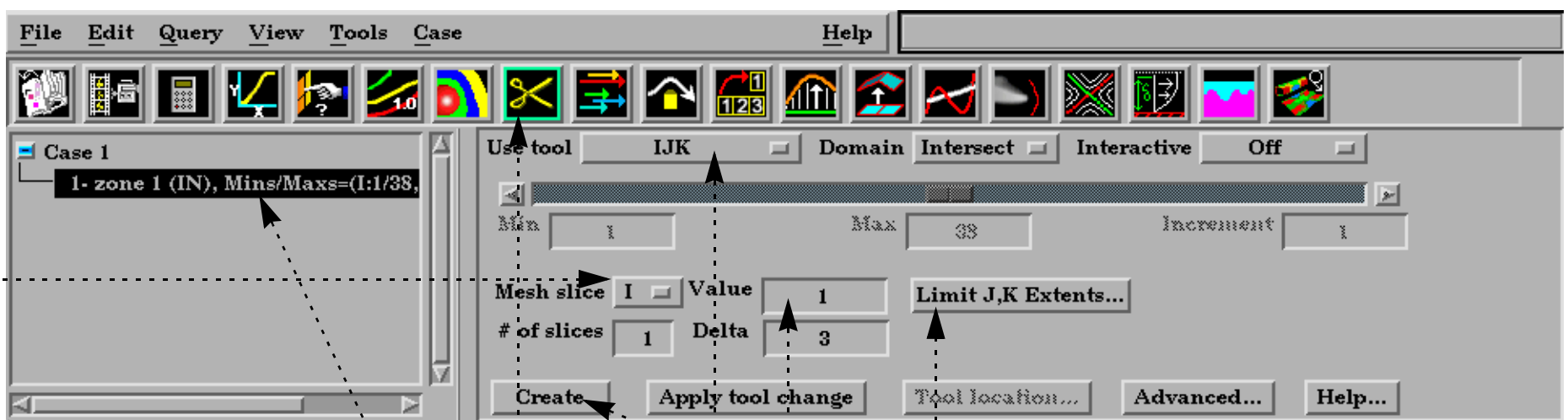

1. Select the parent part....
2. Click the Clip icon.....
3. Select IJK from the Use Tool pulldown.....
4. Select the desired fixed dimension from the Mesh Slice pulldown.
5. Enter the value for the fixed dimension in the Value text field and press return.
6. If you desire to modify values for the Min, Max, and Step for the two free dimensions, click this and the dialog below will open up.
7. Click Create.

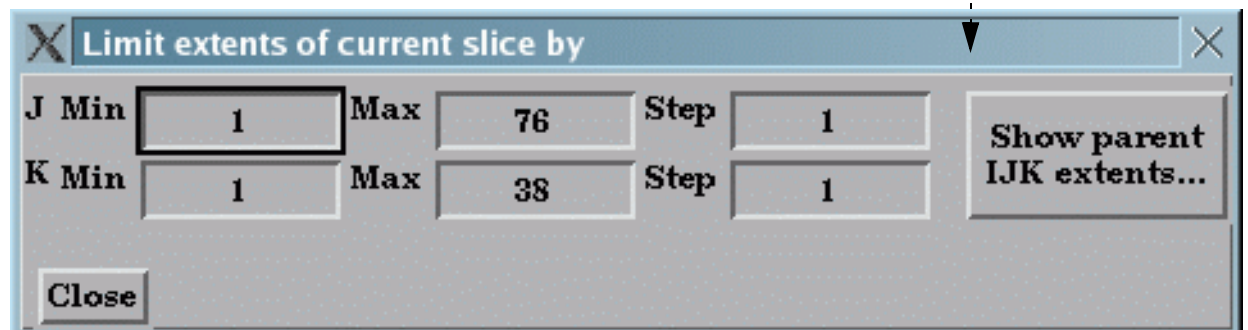

Note that you can change the fixed dimension of an IJK clip at any time (with the Mesh Slice pulldown). If you change one of the numeric values, remember to press return for the change to take effect.



ADVANCED USAGE

Interactive IJK Clipping

You can interactively sweep through the range of the fixed dimension by adjusting a slider with the mouse.

1. Double-click the desired IJK clip part in the parts list.
2. Change Interactive to Manual, to enable sweeping.
3. Adjust the slider with the mouse.

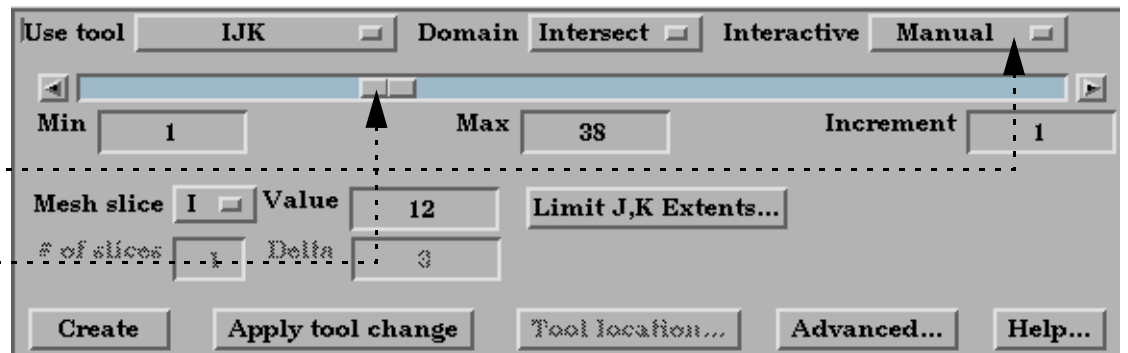

Changing IJK Step Refinement

You can modify block-structured model parts to any level of IJK step refinement with proper updating of all dependent parts and variables.

1. Select **Edit > Part Feature Detail Editors > Model Parts ...** to open the Feature Detail Editor (Model) dialog.

2. Select the structured part (or parts).

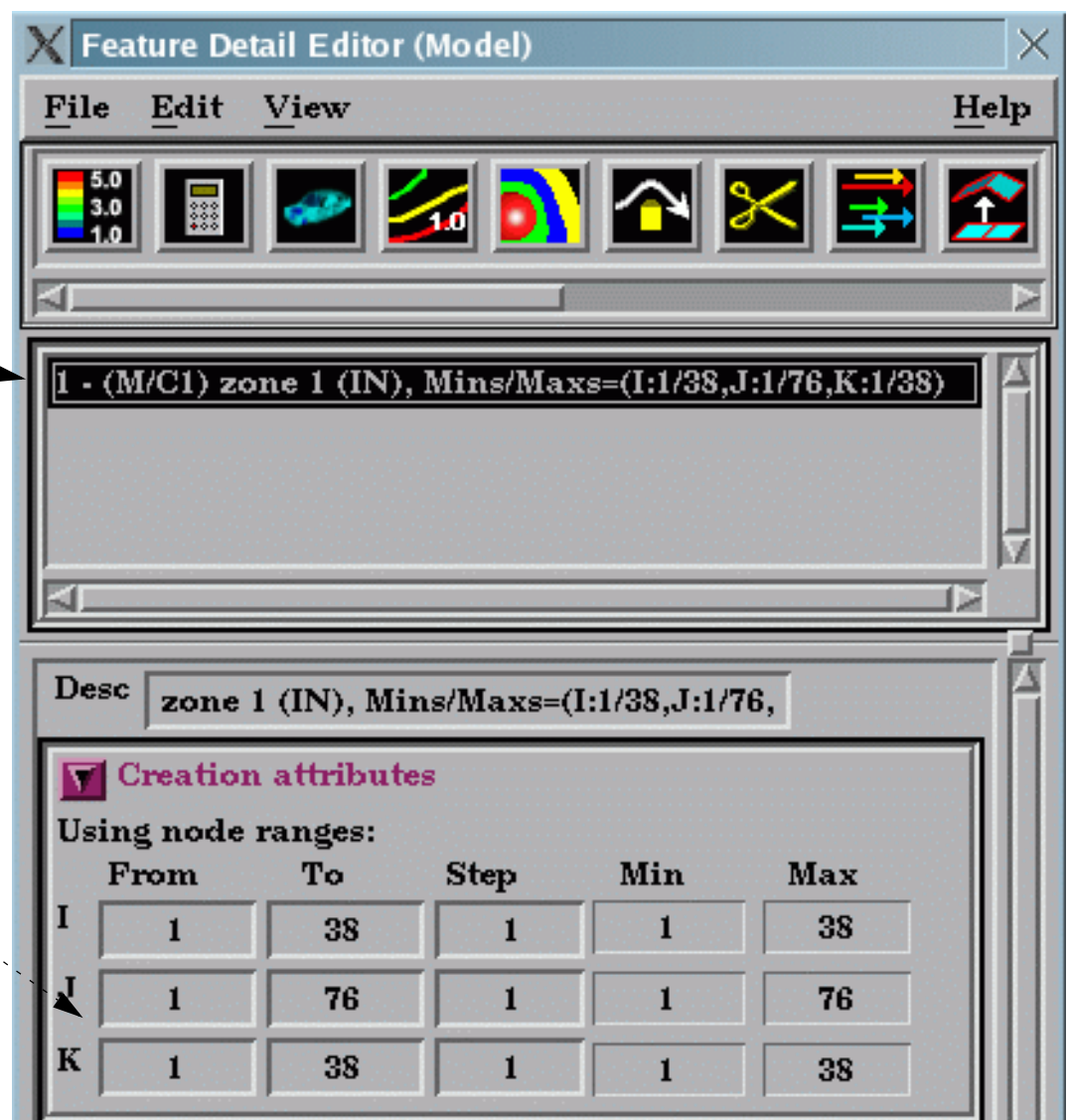

3. In the Creation Attributes area, enter values into the From, To, and Step fields based on their Min and Max limits to update the refinement of the respective I, J, and/or K mesh component directions (remember to press Return).

Clipping Plane Animation

Although you can interactively sweep an IJK clip through a mesh, it is sometimes desirable to have EnSight automatically calculate a series of IJK clips for you. These can then be replayed (as fast as your graphics hardware will permit) using EnSight's Flipbook Animation facility. See [How To Create a Flipbook Animation](#) for more information.



SEE ALSO

[Introduction to Part Creation](#)
[How To Create a Flipbook Animation.](#)

Other clips:

[How to Create Clip Lines](#)
[How to Create Clip Planes](#)
[How to Create Quadric Clips](#)
[How to Create XYZ Clips](#)
[How to Create RTZ Clips](#)
[How to Create Box Clips.](#)

User Manual: [Clip Create/Update](#)





Create XYZ Clips

INTRODUCTION

An XYZ clip is a 1D or 2D slice through 2D or 3D meshes (structured or unstructured). The resulting clip is a 1D or 2D mesh slice where one of the dimensions (e.g. X) is held constant (or fixed) while the other one or two dimensions (e.g. Y and Z) vary in reference to the local frame of the mesh. XYZ clips can be interactively animated throughout the range of the fixed dimension by manipulating a slider. The minimum, maximum, and step size of the range of the interactive fixed dimension can be set by the user.

BASIC OPERATION

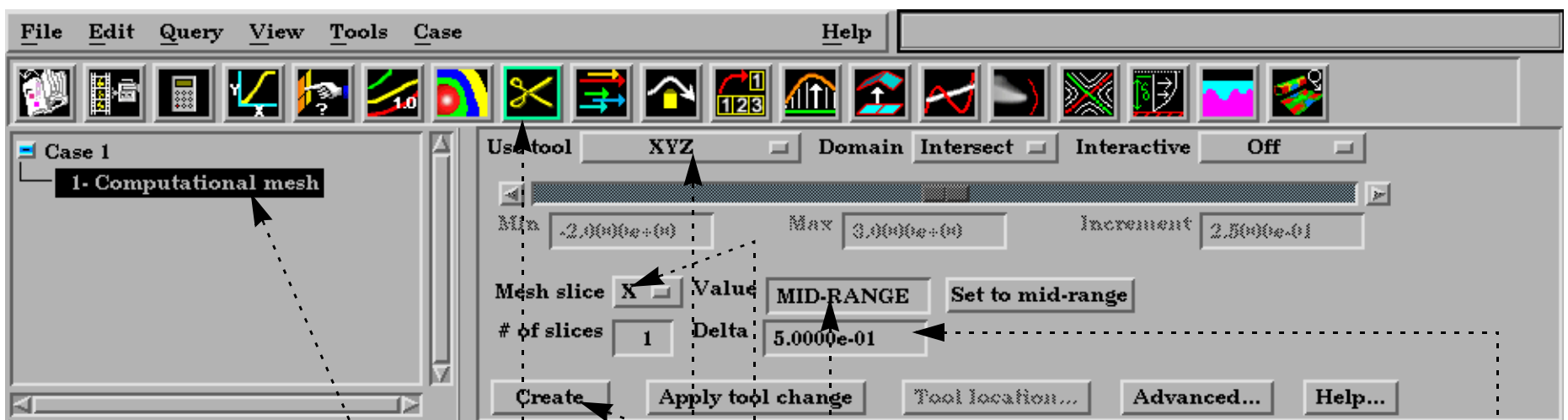

1. Select the parent part.....
2. Click the Clip icon.....
3. Select XYZ from the Use Tool pulldown.....
4. Select the desired fixed dimension from the Mesh Slice pulldown.
5. Enter the value for the fixed dimension in the Value text field and press return.
6. Click Create.

Note: Multiple slices with a delta in the normal direction can be created easily by setting these values.....

Note that you can change the fixed dimension of an XYZ clip at any time (with the Mesh Slice pulldown). If you change the numeric value, remember to press return for the change to take effect.



ADVANCED USAGE

Interactive XYZ Clipping

You can interactively sweep through the range of the fixed dimension by adjusting a slider with the mouse.

1. Double-click the desired XYZ clip part in the main parts list.
2. Change Interactive to Manual to enable sweeping.
3. If desired, enter values for the Min, Max, and Increment to override the defaults (remember to press return).
4. Adjust the slider with the mouse.

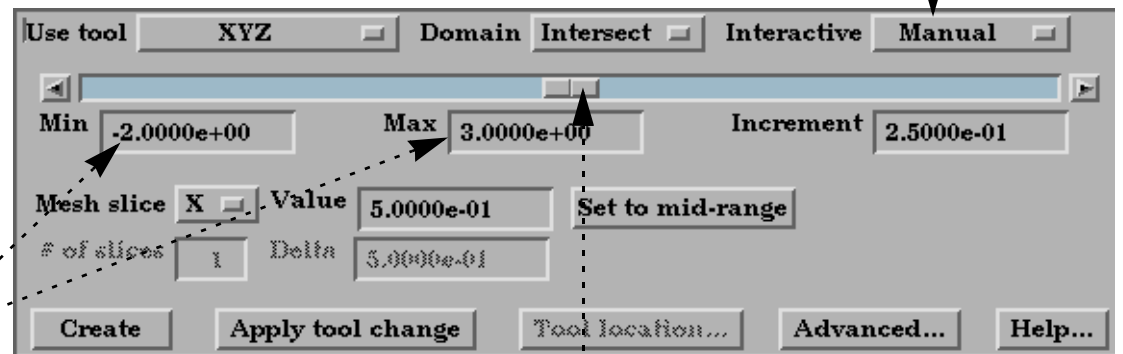

Crinkly XYZ Clipping

You can check the integrity of your mesh by clipping with a crinkly intersection. Specifying a crinkly domain results in a part composed of all the elements that intersect the mesh slice value.

1. Change the Domain to Crinkly

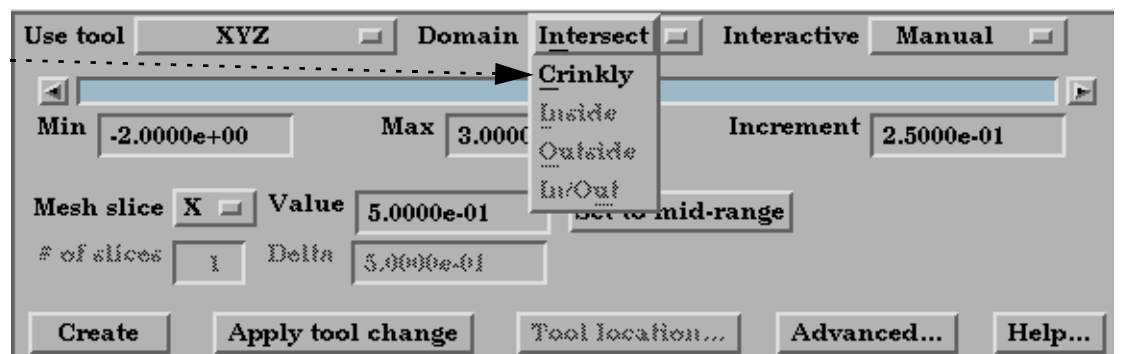

Clipping Plane Animation

Although you can interactively sweep an XYZ clip through a mesh, it is sometimes desirable to have EnSight automatically calculate a series of XYZ clips for you. These can then be replayed (as fast as your graphics hardware will permit) using EnSight's Flipbook Animation facility. See [How To Create a Flipbook Animation](#) for more information.

SEE ALSO

- [Introduction to Part Creation](#)
- [How To Create a Flipbook Animation](#)

Other clips:

- [How to Create Clip Lines](#)
- [How to Create Clip Planes](#)
- [How to Create Quadric Clips](#)
- [How to Create IJK Clips](#)
- [How to Create RTZ Clips](#)
- [How to Create Box Clips](#)

User Manual: [Clip Create/Update](#)



Create RTZ Clips

INTRODUCTION

An RTZ clip is a 1D or 2D slice through 2D or 3D meshes (structured or unstructured). The resulting clip is a 1D or 2D mesh slice where one of the dimensions (e.g. R, "radial component") is held constant (or fixed) while the other one or two dimensions (e.g. T, "theta component" and Z, "z axis component") vary in reference to the local frame of the mesh. RTZ clips can be interactively animated throughout the range of the fixed dimension by manipulating a slider. The minimum, maximum, and step size of the range of the interactive fixed dimension can be set by the user.

BASIC OPERATION

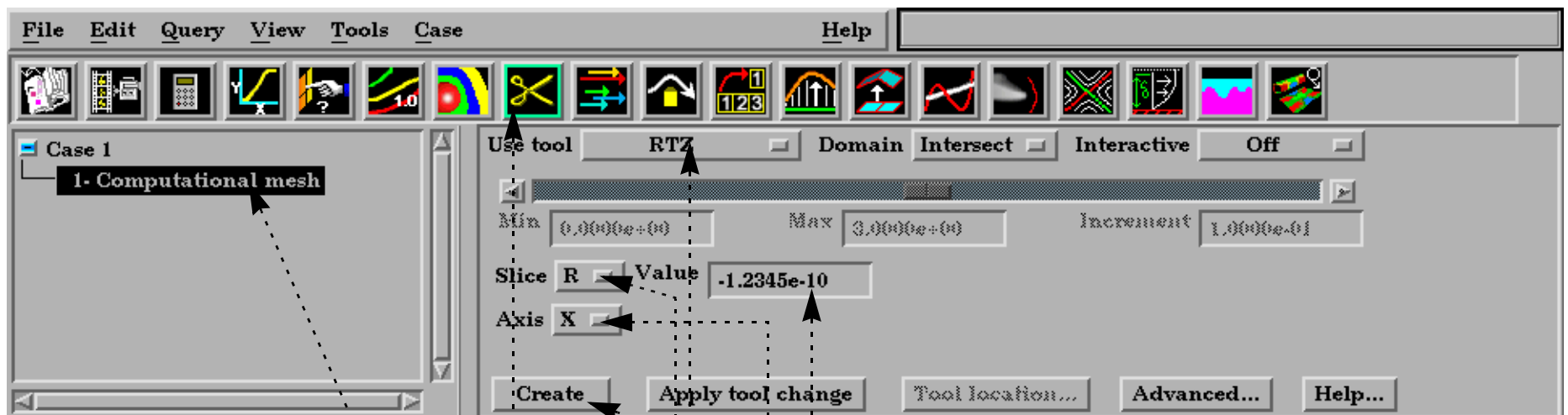

1. Select the parent part.
2. Click the Clip icon.
3. Select RTZ from the Use Tool pulldown.
4. Select the Axis that describes the cylindrical length.
5. Select the desired fixed dimension of the slice (R, T, or Z).
6. Enter the value for the slice (the value of R, T, or Z), and press return.
7. Click Create.

Note that you can change the fixed dimension of an RTZ clip at any time (with the Slice pulldown). If you change the numeric value, remember to press return for the change to take effect.

ADVANCED USAGE

Interactive RTZ Clipping

You can interactively sweep through the range of the fixed dimension by adjusting a slider with the mouse.

1. Double-click the desired RTZ clip part in the main parts list.
2. Change Interactive to Manual to enable sweeping.
3. If desired, enter values for the Min, Max, and Increment to override the defaults (remember to press return).
4. Adjust the slider with the mouse.

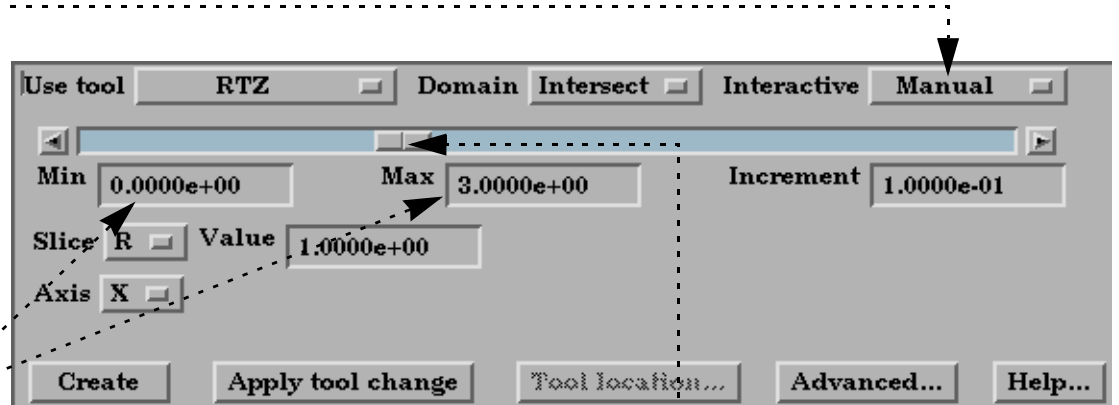



Crinkly RTZ Clipping

You can check the integrity of your mesh by clipping with a crinkly intersection. Specifying a crinkly domain results in a part composed of all the elements that intersect the mesh slice value. Crinkly clipping cannot be done interactively.

1. Change the Domain to Crinkly

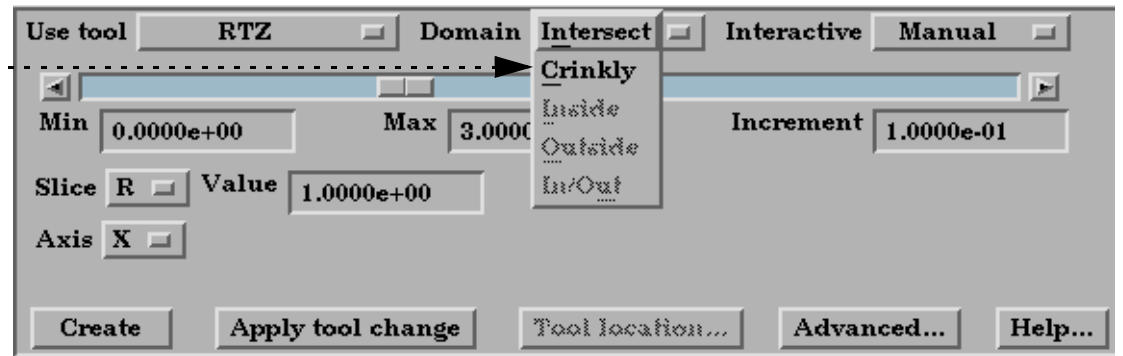

Clipping Plane Animation

Although you can interactively sweep an RTZ clip through a mesh, it is sometimes desirable to have EnSight automatically calculate a series of RTZ clips for you. These can then be replayed (as fast as your graphics hardware will permit) using EnSight's Flipbook Animation facility. See [How To Create a Flipbook Animation](#) for more information.

OTHER NOTES

Inside, Outside, and In/Out cutting are disabled for this clipping type because it has no meaning for T. And if you desire this effect for Z or R, you can use a plane clip or cylindrical clip instead.

SEE ALSO

[Introduction to Part Creation](#)
[How To Create a Flipbook Animation](#)

Other clips:

[How to Create Clip Lines](#)
[How to Create Clip Planes](#)
[How to Create Quadric Clips](#)
[How to Create IJK Clips](#)
[How to Create XYZ Clips](#)
[How to Create Box Clips](#)

User Manual: [Clip Create/Update](#)

INTRODUCTION

A Revolution Tool clip can be made using the surface of revolution tool. It can be the surface created by the intersection of the surface of revolution tool and the model, the elements intersected by the surface of revolution tool (crinkly), or the volume of the inside and/or the outside domain swept by the revolution tool. This clip does not have interactive manipulation capability, with a slider or by dragging the tool with the mouse. However, the tool can be manipulated and the clip updated.

BASIC OPERATION

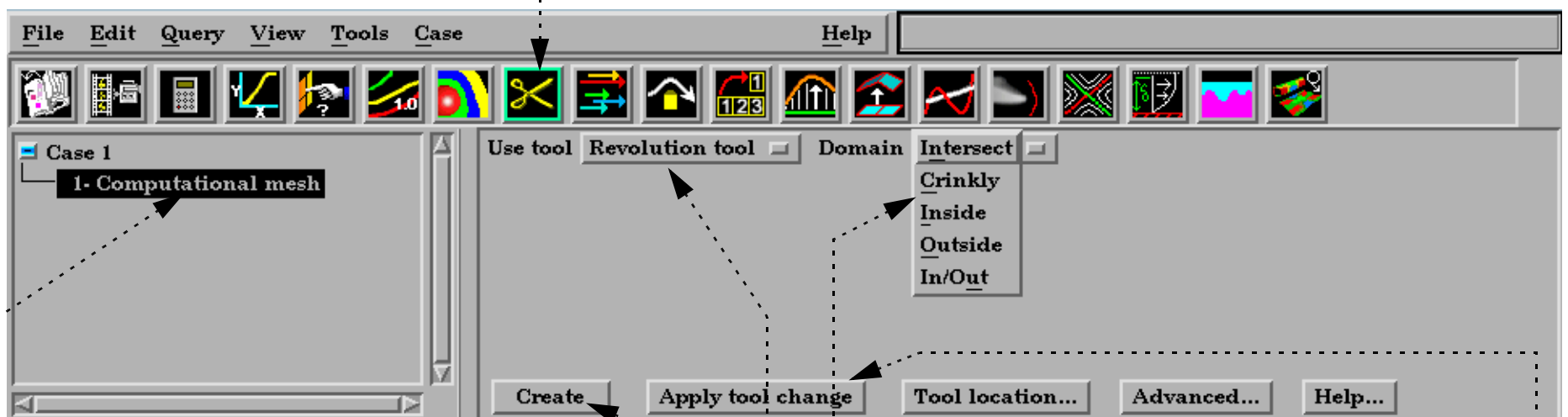

1. Place the Surface of Revolution Tool at the desired location. See [How To Use the Surface of Revolution Tool](#).
2. Select the parent part.
3. Click the Clip icon.
4. Select Revolution Tool from the Use Tool pulldown.
5. Select the desired Domain.

6. Click Create.

Note that you can manipulate the Surface of Revolution tool and update your clip by clicking Apply Tool Change.

You can also change the domain, and the clip will change.

ADVANCED USAGE

SEE ALSO

[Introduction to Part Creation](#)

Other clips:

- [How to Create Clip Lines](#)
- [How to Create Clip Planes](#)
- [How to Create Quadric Clips](#)
- [How to Create XYZ Clips](#)
- [How to Create RTZ Clips](#)
- [How to Create Box Clips](#)
- [How to Create IJK Clips](#)
- [How to Create Revolution of 1D Part Clips.](#)

User Manual: [Clip Create/Update](#)



INTRODUCTION

A Revolution of 1D Part clip can be made using a 1D part and a user specified axis. It can be the surface created by the intersection of the 1D part about the axis and the model, the elements intersected by the 1D part about the axis (crinkly), or the volume of the inside and/or the outside domain swept by the 1D part about the axis. This clip does not have interactive manipulation capability, with a slider or by dragging the tool with the mouse. However, if the 1D part is capable of being moved, you can move it and the revolution clip will update.

BASIC OPERATION

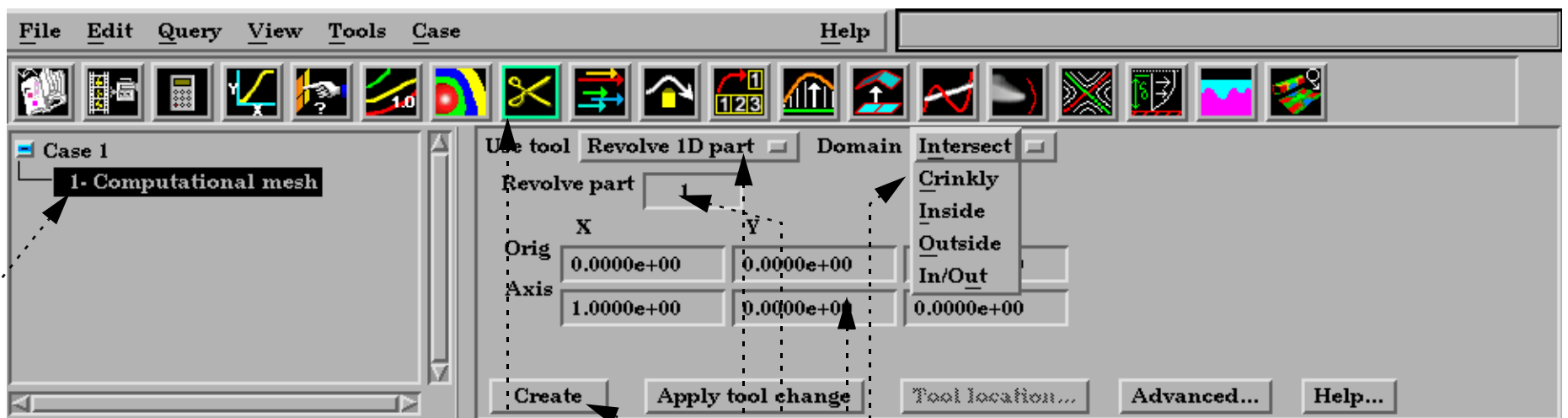

1. Select the parent part.
2. Click the Clip Icon.
3. Select Revolve 1D Part from the Use Tool pulldown.
4. Enter the 1D part to use.
5. Set the desired origin and axis of the revolution.
6. Select the desired Domain.
6. Click Create.

Note that you can manipulate the 1D part or the origin and axis and the clip will update.

You can also change the domain, and the clip will change.

ADVANCED USAGE

SEE ALSO

[Introduction to Part Creation](#)

Other clips:

[How to Create Clip Lines](#)

[How to Create Clip Planes](#)

[How to Create Quadric Clips](#)

[How to Create XYZ Clips](#)

[How to Create RTZ Clips](#)

[How to Create Box Clips](#)

[How to Create IJK Clips](#)

[How to Create Revolution Tool Clips.](#)

User Manual: [Clip Create/Update](#)

INTRODUCTION

Double Clicking on the Clip Create/Update Icon brings up the Feature Detail Editor (Clips), the Creation attributes section of which offers access to one type of clip creation which is not available in the Quick Interaction area. It is possible to create a 3D Quadric clip using the General Quadric option by directly specifying the coefficients of a general quadric equation.

These coefficient values represent the general equation of a Quadric surface. They can be changed by modifying the coefficient values. No tool exists corresponding to this equation.

$$AX^2+BY^2+CZ^2+DXY+EYZ+FXZ+GX+HY+IZ=J$$

BASIC OPERATION

1. Get to the Feature Detail Editor for clips.
The easiest way to do this is to double click the Clip Feature Icon.
2. Select the parent part(s) in the Parts list.

3. Choose the General Quadric Tool.
4. Choose the desired Domain (Intersect, Crinkly, Inside, Outside, or In/Out)
5. Edit the coefficients.
3. Click the Create button.

Note: The Animation Delta is not available for general quadric clips.

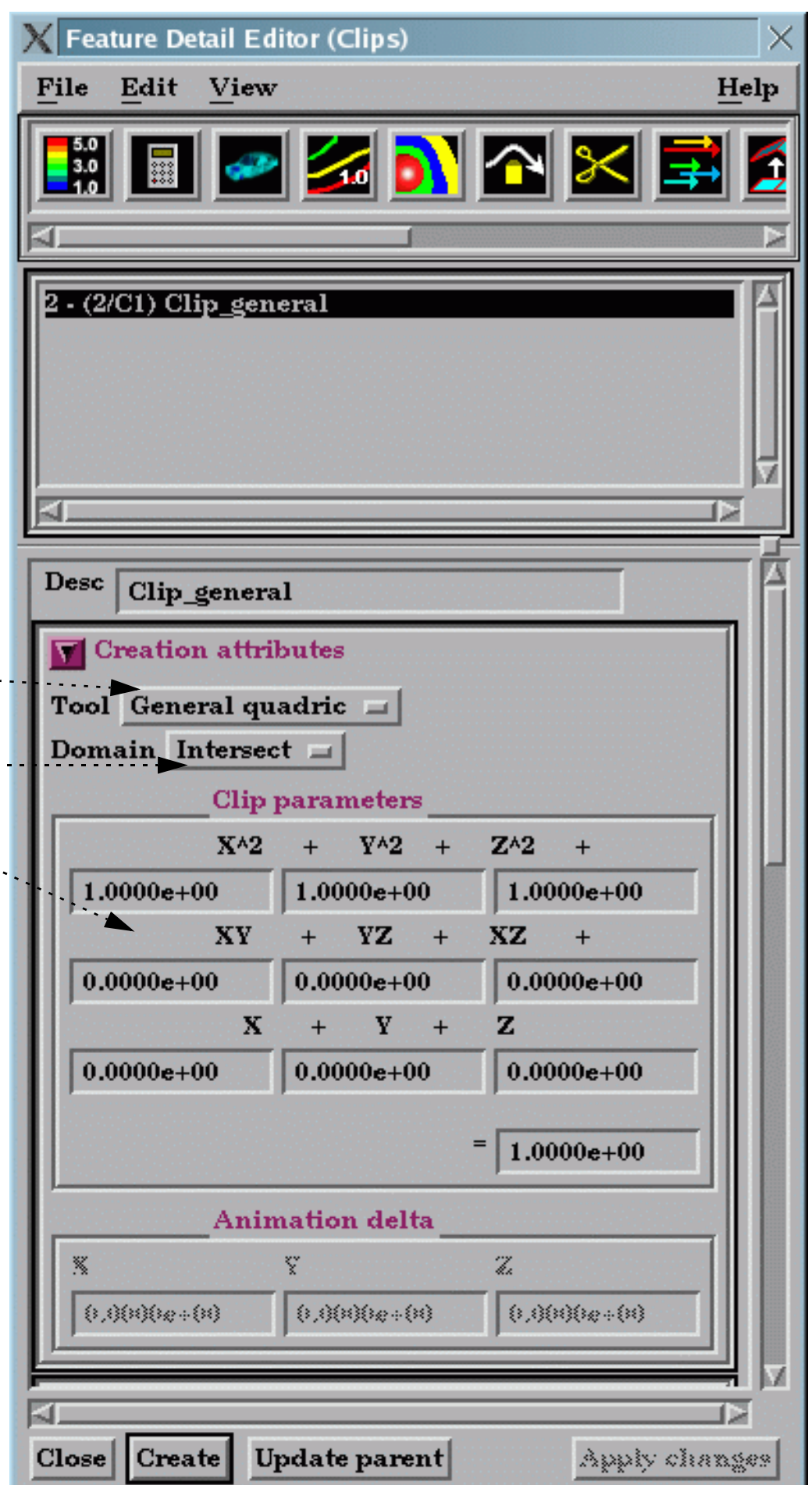



SEE ALSO

[Introduction to Part Creation](#)

Other clips:

[How to Create Clip Lines](#)

[How to Create Clip Planes](#)

[How to Create Quadric Clips](#)

[How to Create XYZ Clips](#)

[How to Create RTZ Clips](#)

[How to Create Box Clips](#)

[How to Create IJK Clips](#)

[How to Create Revolution Tool Clips.](#)

User Manual: [Clip Create/Update](#)



Create Vector Arrows

INTRODUCTION

Vector arrows display the direction and magnitude of a vector at discrete locations in a model. Although vector magnitude can be visualized with other methods (e.g. color), important directional information is provided by the arrows.

Vector arrows have numerous attributes including length scale, tip style and size, projection, origin location, and display filters based on vector magnitude.

BASIC OPERATION

2. Click the Vector Arrows icon.

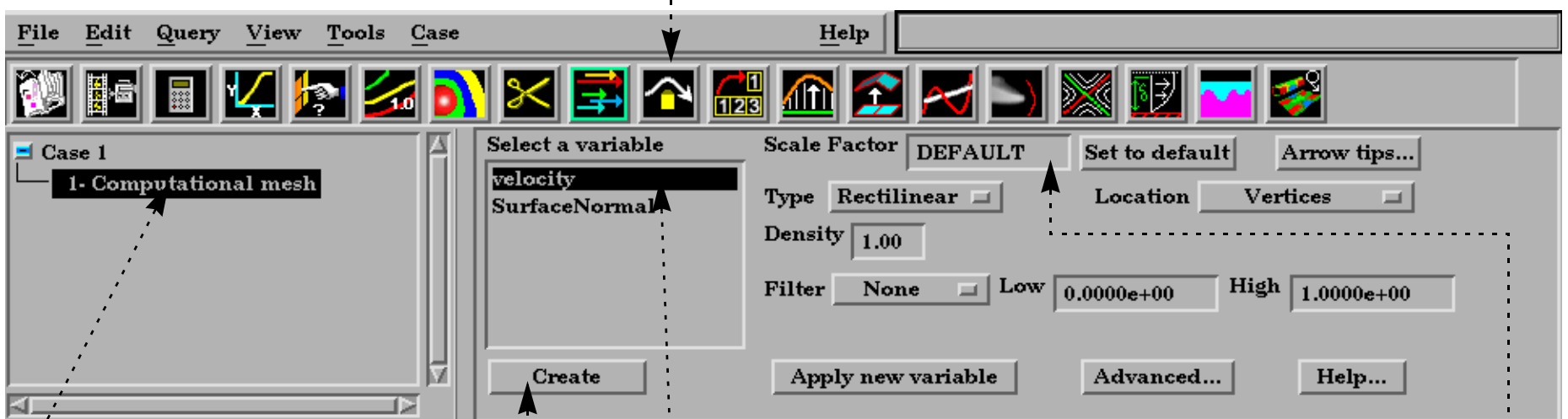

1. Select the parent part.

3. Select the vector variable to use.

4. Click Get Default to load a suitable Scale Factor.

5. Click "Create".

Arrow Tips

To change the arrow tip shape, click the Arrow Tips button to open the Vector Arrow Tip Settings dialog:

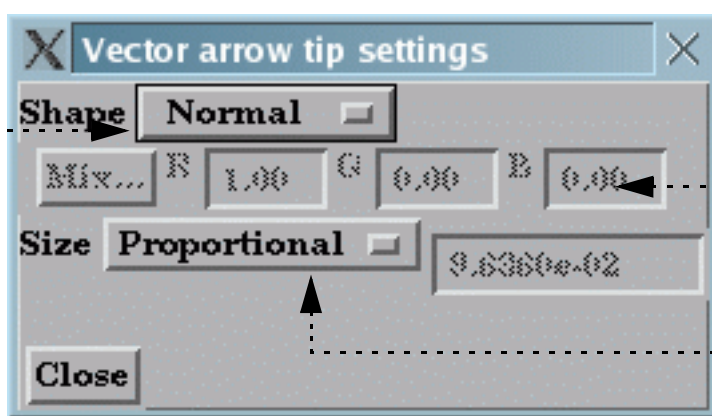





1. Select the desired tip shape from the Shape pulldown (see description at right).

2. Select a color (for Tipped shape only).

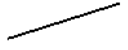
3. From the Size pulldown, select whether tip scaling is Fixed (and enter an appropriate value in the text field) or Proportional to the local vector magnitude.

Tip Shape Choices:

- None No tip (default). 
- Cone Solid cone shape 
- Normal Single wedge. Good for 2D problems. Plane of the wedge is based on the relative magnitudes of the components. 
- Triangles Two intersecting triangles. Good for 2D/3D problems. 
- Tipped End of the shaft colored in a different color. Good where other shapes yield too much visual clutter. 



Other Vector Arrow Attributes

Other vector arrow attributes control the type of arrow, the location of the arrow origin, and arrow filtering options based on vector magnitude:

1. Double-click the desired vector arrow part in the parts list.

2. Select the desired type from the Type pulldown.

Choices are:

- | | |
|-------------|---|
| Rectilinear | Standard vector arrows: shaft points in local vector direction with length equal to vector magnitude scaled by Scale Factor Value. |
| Rect. Fixed | Same as Rectilinear except that length is set by Scale Factor value independent of vector magnitude. |
| Curved | Arrow shaft is the path of a particle trace in the local flow field. Scale Factor becomes "Time" and controls the duration (stopping criteria) for each trace. WARNING! This can take a great deal of time for large numbers of vector arrows and/or long Time values! |

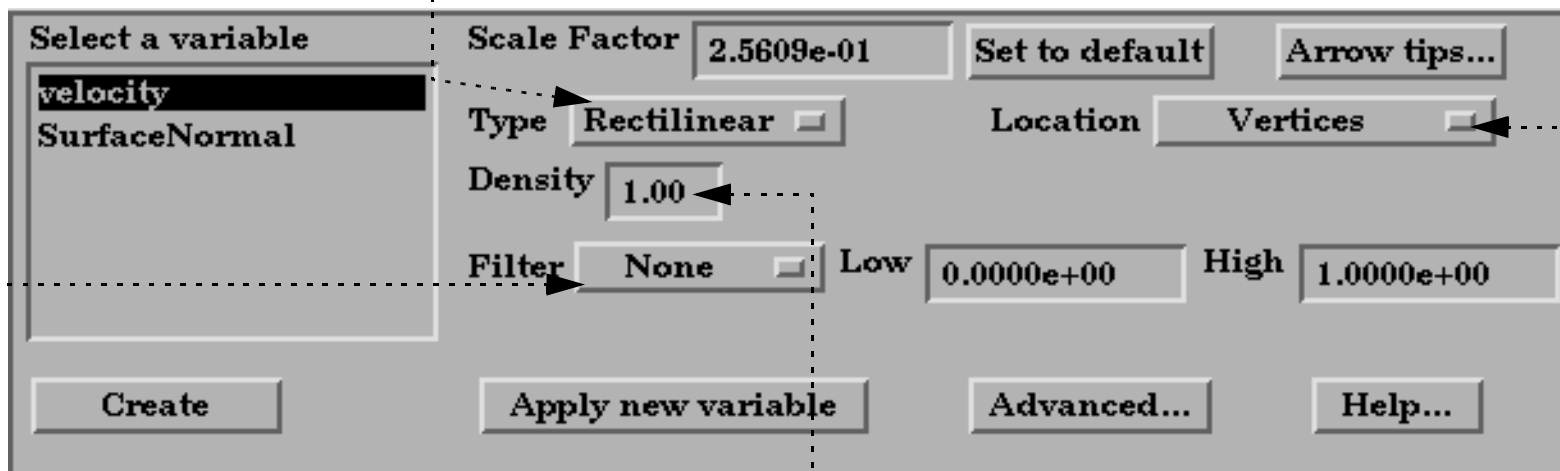

3. Select the desired filter type from the Filter pulldown.

Choices are:

- | | |
|----------|---|
| None | No filtering – all vector arrows appear. |
| Low | Display only those arrows with magnitude <i>above</i> the value in the Low text field. |
| Band | Display only those arrows with magnitude <i>below</i> Low and <i>above</i> High (opposite of Low/High). |
| High | Display only those arrows with magnitude <i>below</i> the value in the High text field. |
| Low/High | Display only those arrows with magnitude <i>between</i> Low and High (opposite of Band). |

4. Select the desired density (0.0 to 1.0).

A density of the arrows will vary from no arrows (0.0) to arrows at every location (1.0). At intermediate densities the arrows are placed randomly.

5. Select the desired arrow origin from the Location pulldown.

Choices are:

- | | |
|----------------|--|
| Node | Arrows originate from each node of the parent part(s). |
| Vertices | Arrows originate only from those nodes that are also vertices of the parent part(s). |
| Element Center | Arrows originate from the geometric center of all elements of the parent part(s). |



ADVANCED USAGE

Although not accessible from the Vector Arrows Quick Interaction area, you can also change the projection of vector arrows and the display offset.

1. Open the Feature Detail Editor for Vector Arrows (Edit > Part Detail Editors... > Vector Arrows).

2. Select the desired vector arrow part.

3. Select the desired projection type from the Projection pulldown.

The projection choices are modified by the settings in the Projection components X,Y,Z numeric fields. These values represent a scaling factor for the component. Zero means that the component should not be considered (and therefore confine the arrows to the plane perpendicular to that axis). One is the default setting; values less than 1 diminish the contribution of the component while values greater than 1 exaggerate the contribution.

Choices for Projection are:

All	Display arrows based on the vector direction as modified by the Projection Component values.
Normal	Display arrows based on the "All" vector but in the direction of the surface normal at the arrow origin.
Tangential	Display arrows based on the "All" vector but projected tangential to the surface at the arrow origin. This is good for locating flow components perpendicular to the main flow direction (such as vortices).
Component	Display <i>both</i> the Normal and the Tangential arrows.

4. Set the desired display offset.

The display offset is used to displace the vector arrows a short distance away from the surface on which they are defined (typically for hardcopy or animation purposes). This is typically necessary when a tangential projection is used and the arrows are coincident with the parent part's surface. Note that a negative offset may be appropriate (depending on orientation).

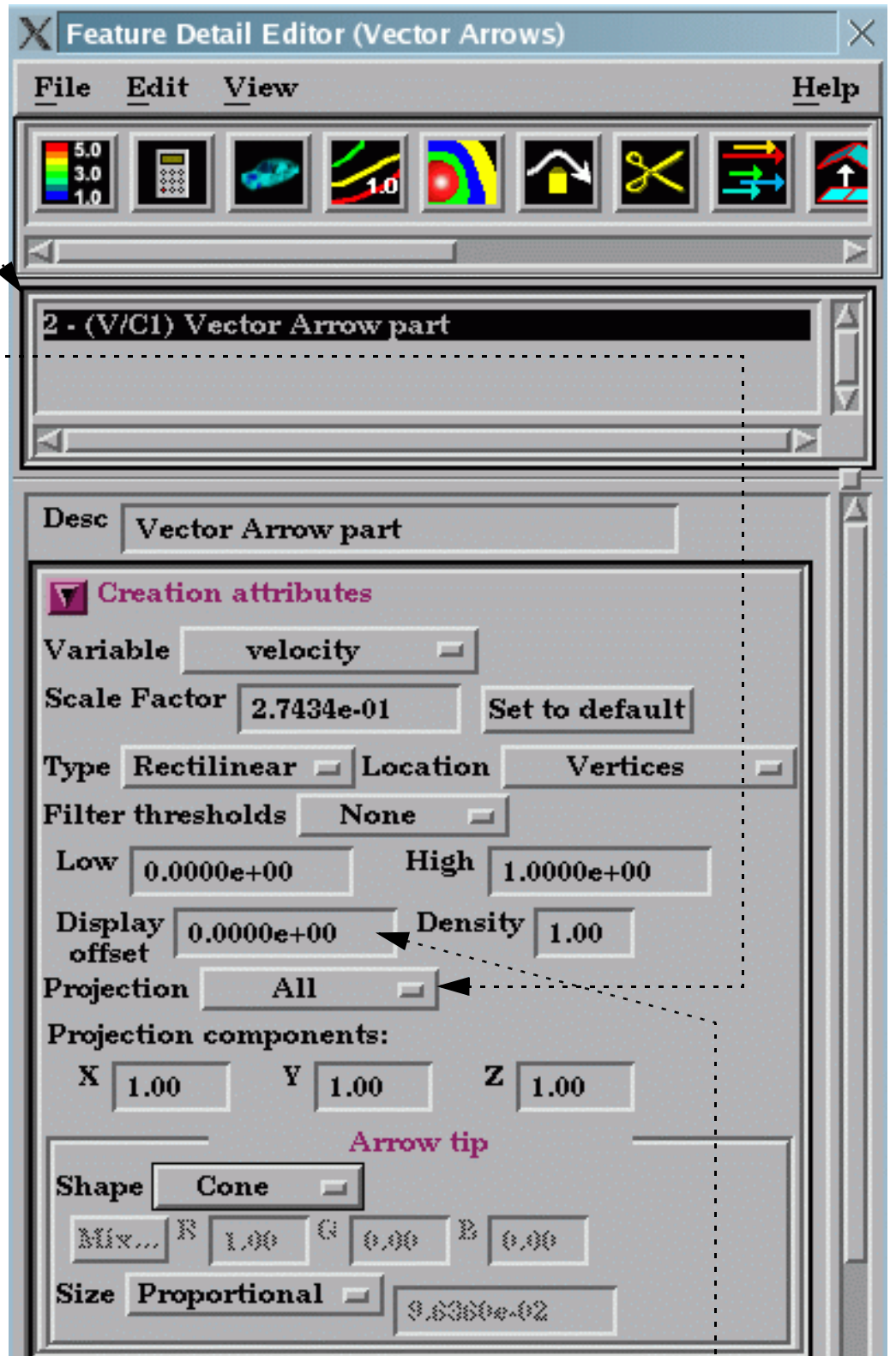

OTHER NOTES

Vector arrows can be animated by animating the parent part (e.g. a clip plane) over space or time using flipbook or keyframe animation. See [How To Create a Flipbook Animation](#) or [How to Create a Keyframe Animation](#) for more information.

If vector arrows are created on a clip through an unstructured mesh, the resulting arrows can be difficult to visualize if the resolution of the underlying mesh varies substantially or is highly irregular. One solution is to create the vector arrows on a *grid clip* rather than the default mesh clip. See [How to Create Clip Planes](#) for more information.



Unlike most part creation operators, vector arrows are created from the client's representation of the part – not the server's. For example, if you have a clip plane that is displayed using a feature-angle or border representation, only those elements comprising the reduced display will yield vector arrows – even though all elements of the clip plane reside on the server. See [How to Change Visual Representation](#) for more information.

Vector arrows with a tangential projection can sometimes be occluded by the surface on which the arrows are defined. To solve this problem, use the Display Offset field to add a small displacement to move the arrows away from the surface. This is most useful for presentation (e.g. hardcopy or animation) output.

SEE ALSO

[Introduction to Part Creation.](#)

User Manual: [Vector Arrow Create/Update](#)



Create Elevated Surfaces

INTRODUCTION

An Elevated Surface is a 2D surface scaled (in the direction of the local surface normal of the parent part) based on the value of a variable. Elevated surfaces resemble topographic maps and are useful for accentuating relative differences in the value of a variable.

BASIC OPERATION

2. Click the elevated surface creation icon.

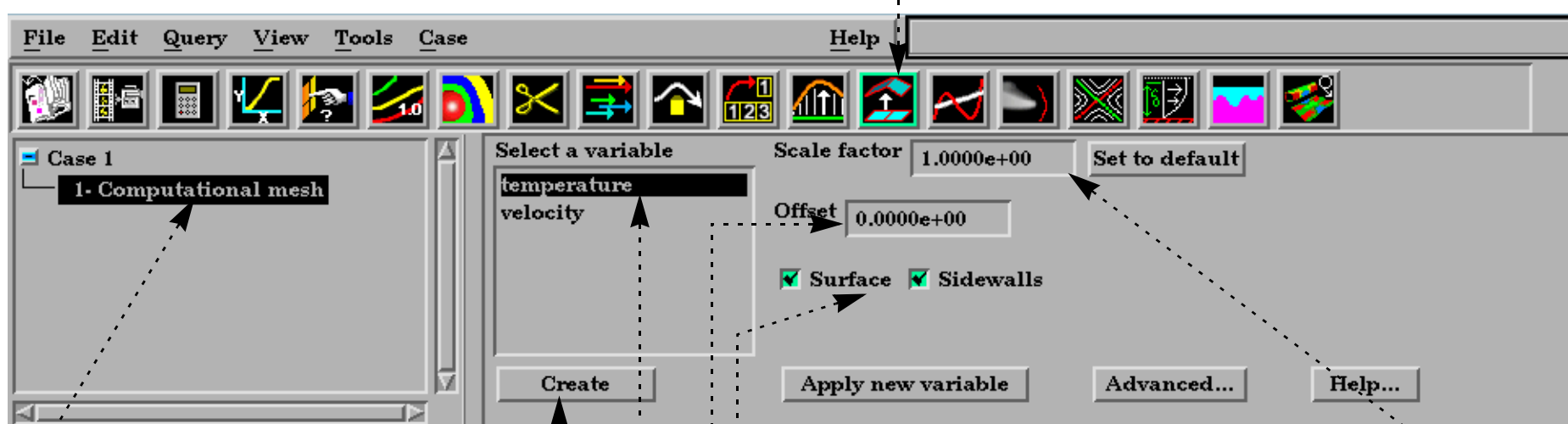

1. Select the parent part.

3. Select the variable to use.

4. Select an appropriate scale factor (or click the Get Default button).

5. If desired, enter an Offset value and press return.
The Offset allows you to “shift” the elevated surface away from the parent, but does not affect the shape.

6. If desired, toggle Surface or Sidewalls off.

The Surface is the actual elevated surface. You can also have Sidewalls which stretch from the border of the parent to the border of the Surface to enclose the created part.

7. Click “Create”.

SEE ALSO

User Manual: [Elevated Surface Create/Update](#)



Create Profile Plots

INTRODUCTION

A profile plot is the 2D counterpart to an elevated surface: a projection away from a 1D part based on the value of a variable. Profile plots can be created on any 1D part: [clip lines](#), [contours](#), [particle traces](#), or model parts consisting of 1D elements.

BASIC OPERATION

2. Click the profile creation icon.

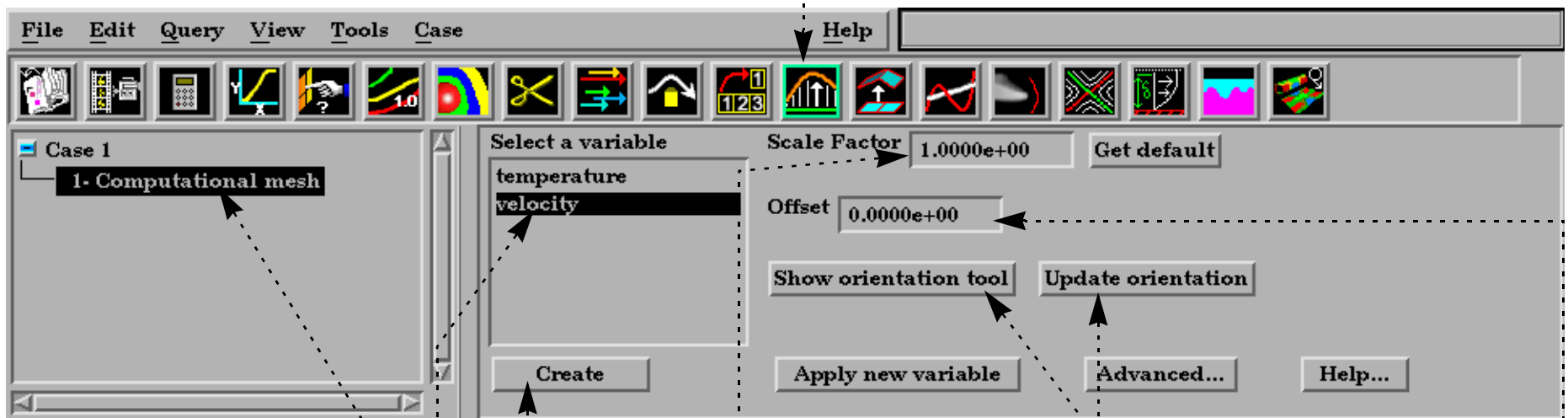

1. Select the parent part...

3. Select the variable to use.

4. Select an appropriate Scale Factor (or click Get Default).

5. If desired, enter an Offset value and press return.

The Offset allows you to “shift” the profile away from the parent, but does not effect the shape.

6. If desired, adjust the orientation of the Plane tool.

The Plane Tool is used to specify the orientation and direction of the profile plot. See below for more information.

7. Click “Create”.

For each node of the parent part, the corresponding node on the *profile curve* is determined by adding the value of the Offset to the selected variable and then multiplying the sum by the Scale Factor. The *projectors* of the profile are the lines that connect the nodes of the parent part to the nodes of the profile curve. The Plane tool is used to specify the orientation and direction of the projectors. The projectors are created parallel to the Plane tool projecting away from the center of the Plane tool (at least where the value of the selected variable plus the Offset is positive).

Although the parent part of a profile plot must be 1D, the nodes that make up the part do not have to be linear. For curved parents, the projectors of the resulting profile plot are still parallel, but they do not all lie in the same plane.

SEE ALSO

User Manual: [Profile Create/Update](#)

INTRODUCTION

EnSight provides several sophisticated tools for extracting computational surfaces from meshes. For clipped surfaces with a defined axis of rotation (such as those created with the quadric clipping tools), the surface can “developed” or unrolled onto a plane. All variables defined on the clip are properly interpolated onto to the developed surface.

A clip can be developed based on curvilinear (radius, z), (theta, z), or (meridian, theta) coordinate projections. The “seam” of the clip can be specified interactively.

BASIC OPERATION

To create a developed surface:

1. First, create the desired quadric clip (cylinder, sphere, or cone).

4. Select the desired projection type (see below for details on the types).....

3. Click the Developed Surface icon.....

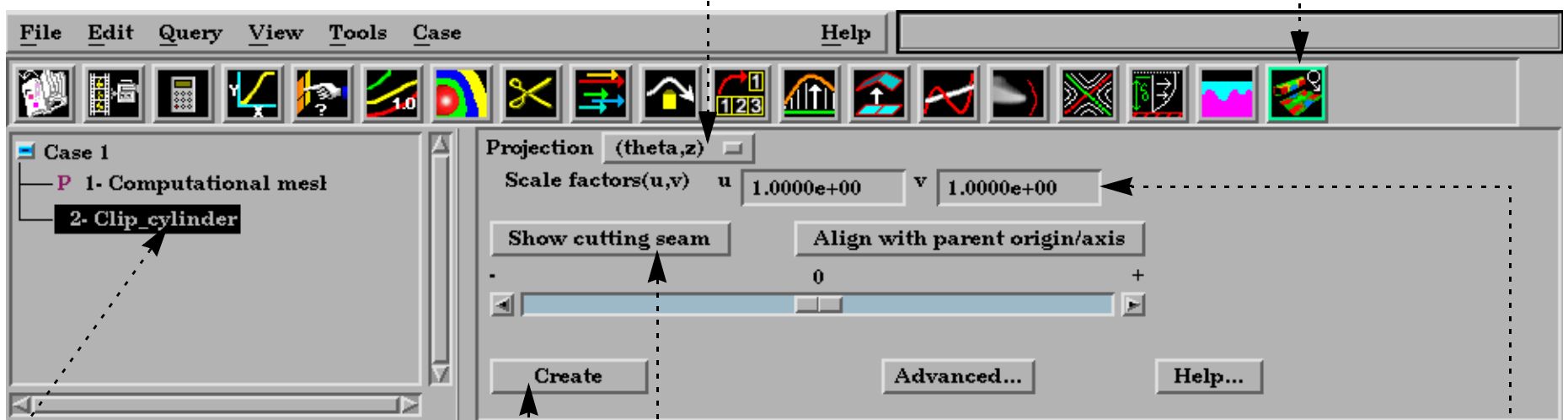

2. Select the parent part for the developed surface (i.e. the part you created in step 1).

5. If applicable for the projection type (and desired) enter u,v scaling factors and press return).

6. To display and change the cutting seam, click the Show Cutting Seam button, and adjust the slider.

7. Click Create.

A part is developed by specifying one of three curvilinear mappings called *developed projections*. The projections are based on the curvilinear coordinates r (radius), z , θ (theta), and m (meridian or longitude). These coordinates are defined relative to the local origin and axis of the tool that created the parent part (e.g. the Cylinder tool). The projections are (r,z) , (θ, z) , and (m, θ) . The u , v scale factors (only for (θ, z) or (m, θ) projections) provide scaling for the coordinates in the listed order. For example, if the projection is (θ, z) then u scales θ and v scales z .

SEE ALSO

[How To Create Quadric Clips](#)

User Manual: [Developed Surface Create/Update](#)



Create Subset Parts

INTRODUCTION

A Subset Part can be created by specifying node and/or element label ranges of a model part. Subset Parts can only be created from model parts that have node and/or element labels. The Subset Part feature can be used to isolate specified nodal and element regions of interest in large data sets.

BASIC OPERATION

1. First, click the Subset Parts creation icon.
2. Now, for each parent model part, enter the part number of the desired parent part in the Add field and press return.
3. Select Elements (or Nodes) to Show.

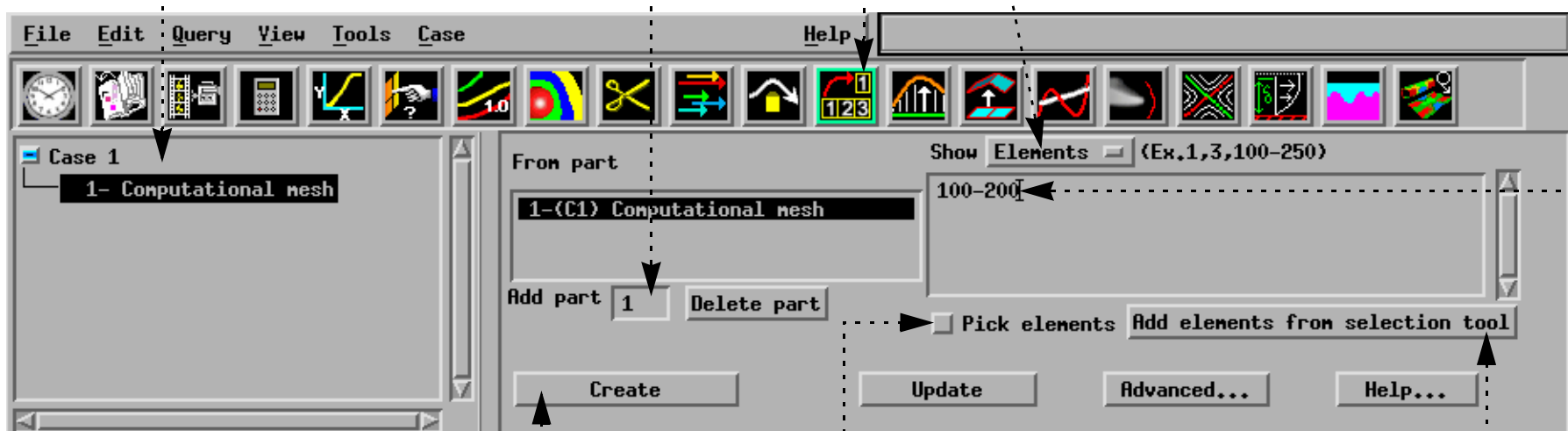

4. Enter the element (or node) label range(s) in the Show List text field (ranges are separated by commas).

OR

Toggle on “Pick elements” and select elements using pick selection, which by default is the “p” keyboard key.

OR

Turn on the selection tool and place it where desired, then click “Add elements from selection tool” to pick all the elements within the tool.

5. Click Create

SEE ALSO

User Manual: [Subset Parts Create/Update](#)





INTRODUCTION

Tensor glyphs display the direction of the eigenvectors for a tensor variable. Controls exist to show just the compressive or tensile eigenvectors, and to selectively show the minor, middle, or major vectors.

Tensor glyphs have numerous attributes including length scale, tips, color, and line width which can be used to indicate compression or tension.

BASIC OPERATION

3. Select the tensor variable to use.
2. Click the Tensor Glyph icon (by default this icon is not displayed unless you have enabled it through Edit > Preferences > General User Interface "Modify and save icon layout").

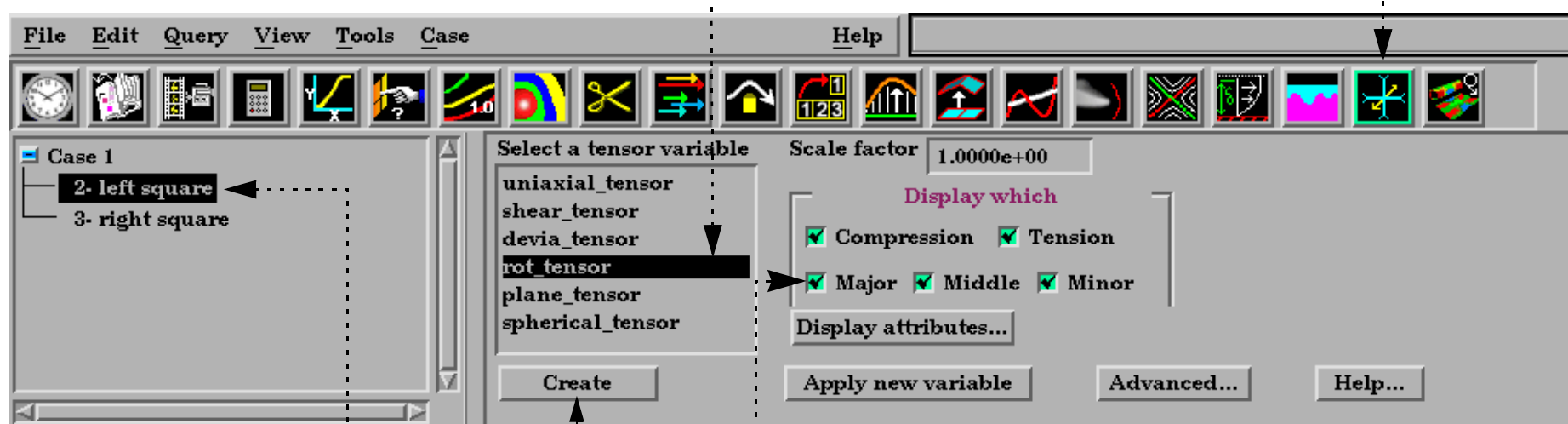

1. Select the parent parts.
4. Select which eigenvectors to display.
5. Click Create.

Display Attributes

The glyph's attributes to indicate tension or compression can be modified in several ways. Click the Display Attributes button to open the Tensor Display Attributes dialog:

1. Select the desired tip shape from the Tip Shape pulldown.

Tip Shape Choices:

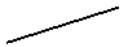
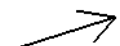
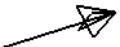
-  None No tip (default)
-  Normal Single wedge. Good for 2D problems. Plane of the wedge is based on the relative magnitudes of the components.
-  Triangles Two intersecting triangles. Good for 2D/3D problems.

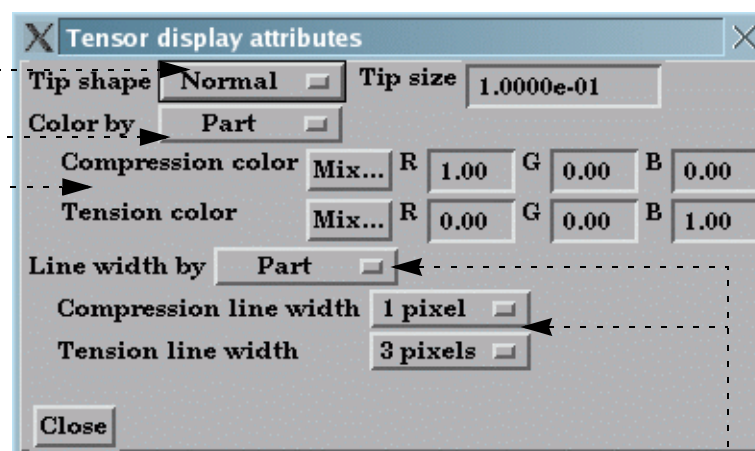

2. The glyph can either be colored by the part color, or show a specified color for compressions and tension.

3. The glyph can either be shown with the line width attribute of the glyph, or show a different line width for tension and compression.



OTHER NOTES

Tensor glyphs can be animated by animating the parent part (e.g. a clip plane) over space or time using flipbook or keyframe animation. See [How To Create Flipbook Animation](#) or [How to Create a Keyframe Animation](#) for more information.

Unlike most part creation operators, tensor glyphs are created from the client's representation of the part - not the server's. For example, if you have a clip plane that is displayed using a feature angle or border representation, only those elements comprising the reduced display will yield tensor glyphs - even though all elements of the clip plane reside on the server. See [How to Change Visual Representation](#) for more information.

SEE ALSO

[Introduction to Part Creation.](#)

User Manual: [Tensor Glyph Parts Create/Update](#)



Display Displacements

INTRODUCTION

In structural mechanics simulations, a common output variable is a set of vectors representing the movement or displacement of geometry. Each displacement vector specifies a translation of a node from its original position (an offset). EnSight can display and animate these displacements to help visualize the relative motion of geometry.

In many cases, the magnitude of the actual displacements is extremely small relative to the size of the model. EnSight provides a displacement factor to scale the vectors and exaggerate the displacement.

BASIC OPERATION



1. Select the parent parts.

2. Click the Part tab.



3. Click the displacement creation icon.

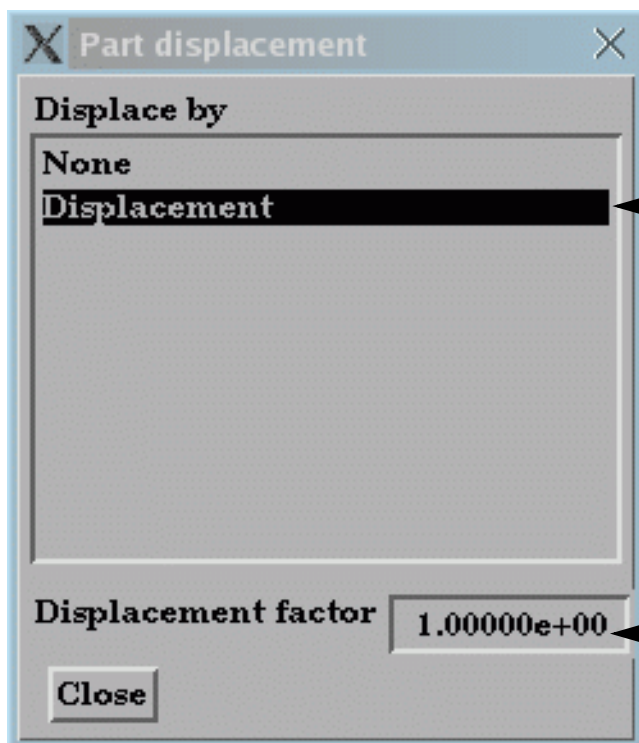

4. Select the variable to use.

5. If desired, enter a value for the Displacement Factor and press return.

Note that your changes in the Quick Interaction area are immediate. Specifying a displacement does not create a new part, it merely sets the displacement attributes for the selected parts.



ADVANCED USAGE

Vibrational analysis typically produces eigenvectors. EnSight can animate these vectors as *mode shapes* to visualize selected vibration modes (each represented by a different displacement vector). The EnSight Flipbook is used to build and load the animation. Once loaded, the animation can be replayed while still providing viewing control. To create a mode shape flipbook:

1. Be sure displacements are active and the Displacement Factor is set to a suitable value (as described above).

2. Click the Flipbook icon.

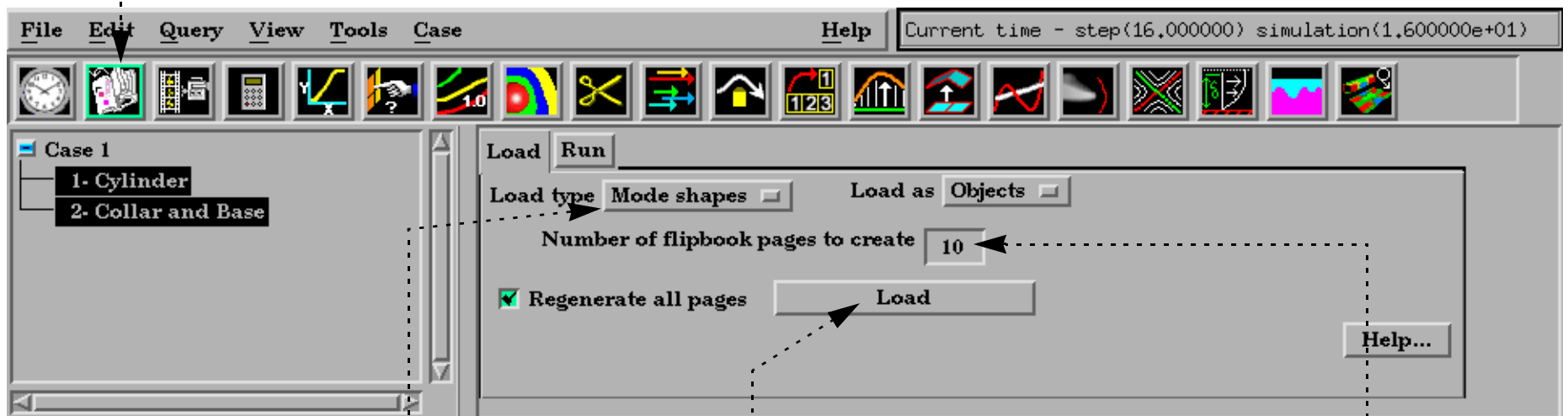

3. Select Mode Shapes from the Load Type pulldown.

4. Enter the desired number of Flipbook pages to create.

5. Click "Load".

6. Once loading is complete it will automatically change to the Run tab and the animation will be running.

The first page of the animation shows the full displacement (as it is shown in the Graphics Window without the Flipbook) while the last page shows full displacement in the opposite direction. Intermediate pages show displacements as driven by the cosine function.

Note that you can create **copies** or **extracts** of parts and simultaneously display them with different mode shape variables or to show the initial static state along with the mode shape animation.

SEE ALSO

See [How To Create a Flipbook Animation](#) for more information on Flipbooks.

User Manual: [Part Displacement](#), [Flipbook Animation](#)

INTRODUCTION

In addition to meshed data consisting of nodes and elements, EnSight also supports *discrete* or *measured* data. A measured dataset consists of a series of arbitrary points in space with no connectivity. Measured data can have associated variable data and can vary over time. Examples of measured data include fuel sprays, multi-phase flows, and experimental data.

Measured data cannot be loaded by itself – you must also specify a regular geometric mesh.

BASIC OPERATION

Measured data is read into EnSight via the same dialog used to read meshed data:

1. Select **File > Data (Reader)...** to open the **File Selection** dialog for data file selection.

2. Find the directory containing the data (see [How To Read Data](#) for more information on using File Selection).

3. If desired, select and specify a (meshed) geometry file and the corresponding result file.

4. Select the measured result file in the Files list.

5. If desired, specify an initial time step (the last step is the default).

6. If you are reading a meshed dataset (as directed in step 3), select the file format.

7. Click **(Set) Measured** to specify the selected measured result file.

8. Click **Okay** to begin the reading process.

9. The **Data Part Loader** dialog corresponding to the selected data file format (as set in step 6) will open. You do not have to perform any further action to load the measured data. However, if you are also loading meshed data, continue with the usual part loading process. For details, see the [How To](#) article for the chosen file format.

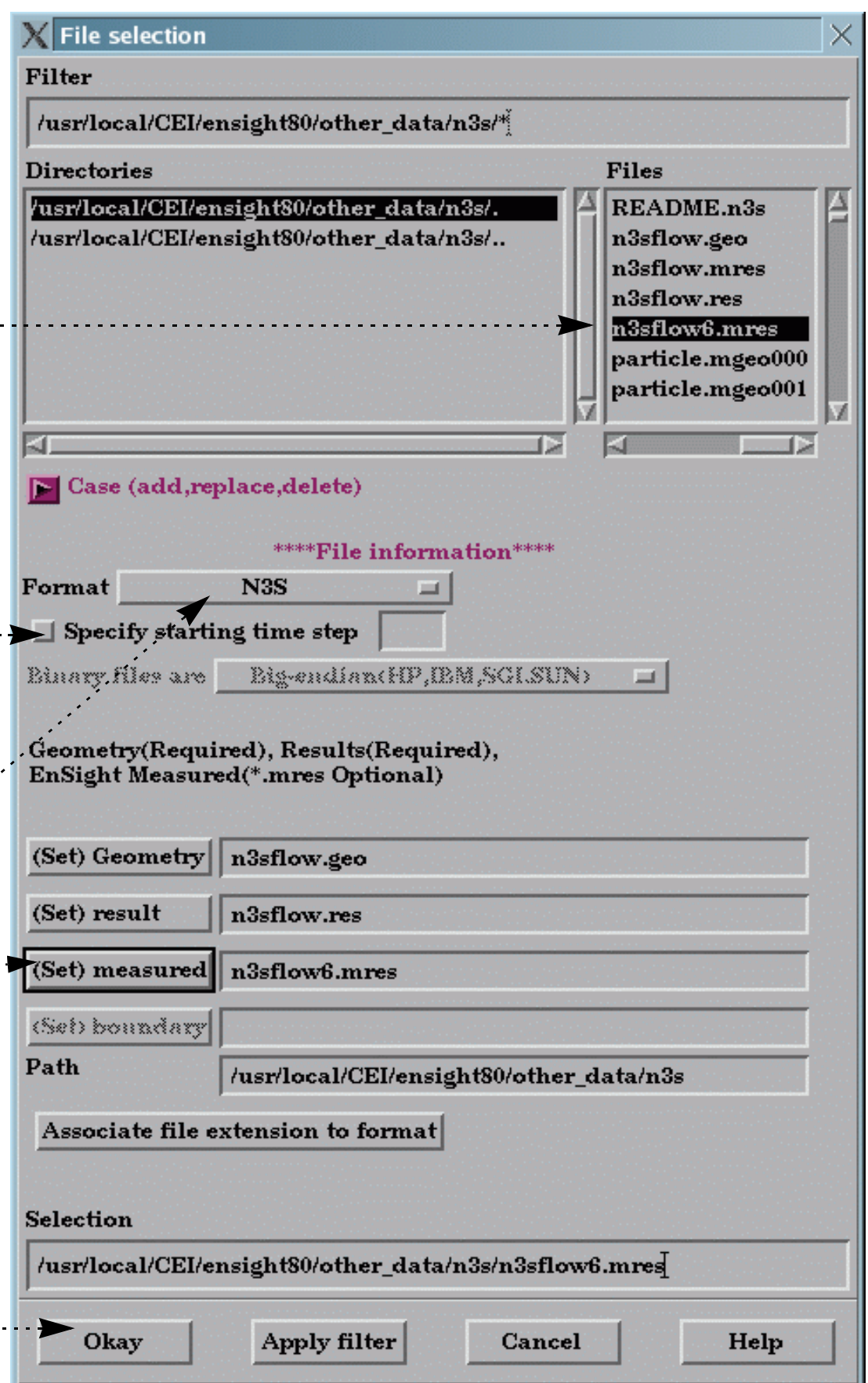



Measured data is represented as a single part. In the Main Parts list you should see a part named “Measured/Particle” after loading.

Measured data is represented as a set of unconnected nodes. You can use EnSight’s ability to display nodes in various ways to accentuate measured data visualization. To change node display:

1. Select the desired measured data part in the Main Parts list.
2. Click Part in the Mode Selection area to enter Part Mode.
3. Click the Node Representation icon to open the Part Node Representation dialog.
4. Select the desired node display type (Dot, Cross, or Sphere). See below for details on each type.
5. If applicable, set desired values for Scale, Detail, Size By, and Variable.

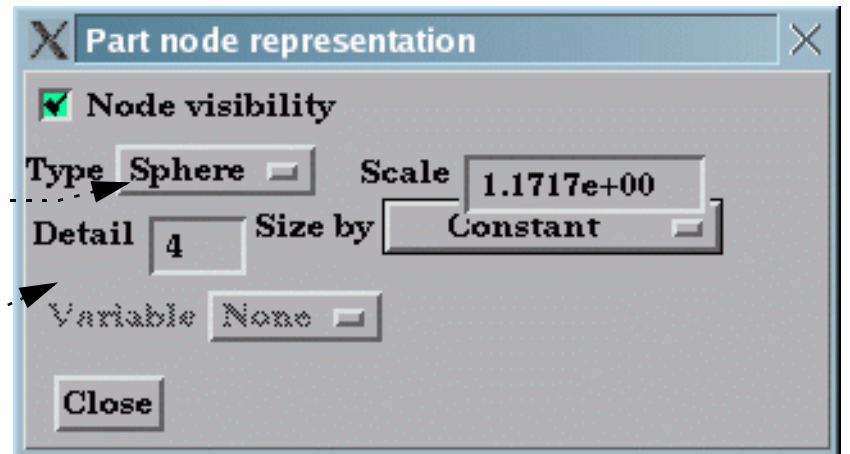
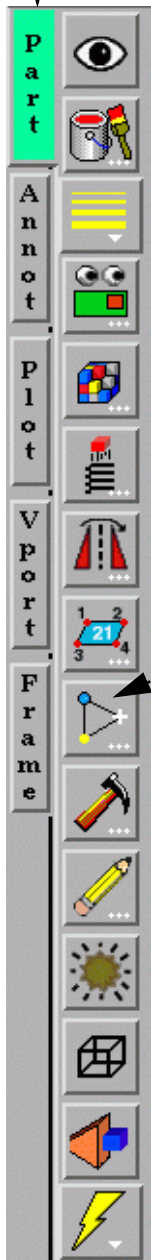

- Dot: nodes are displayed as points.
- Cross: nodes are displayed as crosses and can be fixed size (size set by the Scale value) or sized based on a Variable (and scaled by the Scale value).
- Sphere: nodes are displayed as spheres and can be fixed size (size set by the Scale value) or sized based on a Variable (and scaled by the Scale value). Sphere detail controlled by Detail value.

OTHER NOTES

The file formats for measured data and the measured results file are detailed in [EnSight5 Measured/Particle File Format](#).

Transient measured data can be animated using either the [flipbook](#) or [keyframe animation](#) capability.

You can load multiple measured datasets simultaneously by using EnSight’s [cases](#) capability.

SEE ALSO

User Manual: [EnSight5 Measured/Particle File Format](#)



Change Time Steps

INTRODUCTION

From its inception, EnSight has been used extensively to postprocess time-varying or transient data. In many cases, dynamic phenomena can only be understood through interactive exploration. The Solution Time Quick Interaction area provides the interface for working with transient data and provides comprehensive control over time handling.

BASIC OPERATION

EnSight provides two ways to work with transient data. By default, time is presented as a series of discrete steps running from zero to the total number of steps minus one. However, you can also present time based on the actual simulation time values found in your results data. The presentation mode is controlled by the Time As pulldown menu. In the dialog below, Time As is set to Step and time is presented as discrete steps running from 0 to 159 (160 total steps). The simulation time (as reported in the top line of the dialog) runs from 1.0 to 160.0.

The current time range is displayed in the Beg and End fields with the current time step shown in the Cur field. You can modify the time range displayed in the slider by editing the Beg and/or End fields (remember to press return). You can change the current time step by editing the Cur field (press return), manipulating the slider, or clicking the left/right slider arrows. Clicking Reset Time Range will reset Beg and End to the full range.

Time scaling and stepping (as manipulated through the slider bar and Beg, Cur, and End fields) can either be Discrete or Continuous. If scaling is Discrete, only your actual time steps as written in the results data can be visualized. In addition, the Beg, Cur, and End fields can only be set to integer values (if Time As is set to Step and Scale Type is Discrete) or actual simulation times represented in your results data (if Time As is set to Sim. Time). If scaling is Continuous, you can display results between your actual output time steps (all variable values are linearly interpolated between the two surrounding time steps). Note that if your mesh is changing over time (either set of elements or element connectivity) you cannot display results continuously.

When you manipulate the slider or change the Cur field, EnSight will perform all tasks necessary to correctly display the new time step in the Graphics Window. Depending on the size of the dataset and the number of additional parts you have created, this may take a significant amount of time. If you wish to create an on-screen animation of your results, use the **Flipbook** facility (click Animate Over Time to quickly jump to the Flipbook Quick Interaction area).

To use the Solution Time Quick Interaction area:

1. Click the **Solution Time icon in the Feature Icon bar.**



2. Make changes as desired.

The Beg and End fields control the available time range (and also the range of the slider action). The range markers on the slider can be moved to set these values or you can enter new values into the fields and press return.

The Current field sets the current time step. Either move the center slider or enter a new value in the field and press return.

Click to display time as annotation in the graphics window.

Click to open the Flipbook Animation Quick Interaction area.

Set Scale Type to Discrete or Continuous (see above for details).

Set the number of time cycles in the time range.

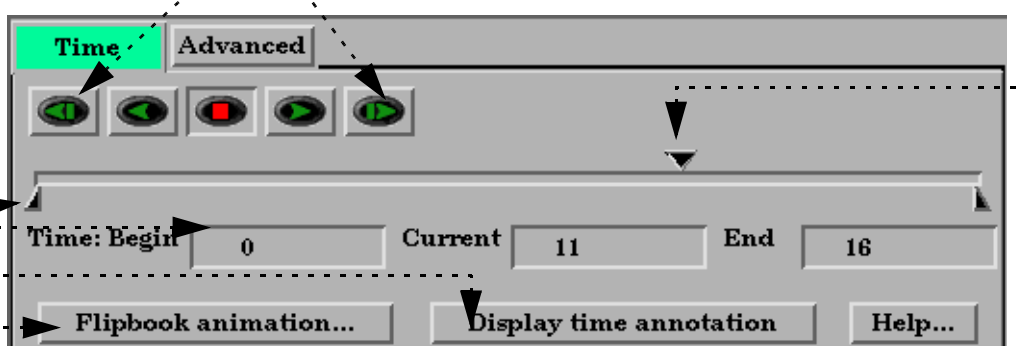

The slider bar lets you step through time. Grab the slider and dial to the desired time or click the left/right slider arrows to increment (the increment can be set by changing the Increment field).

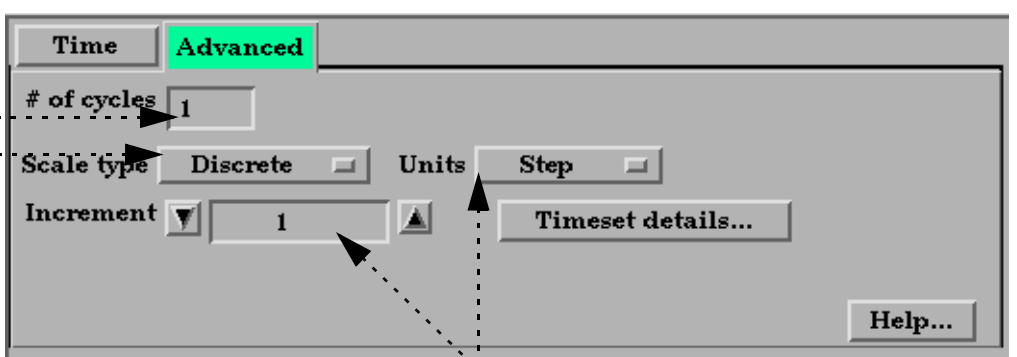

Set Units to Step or Sim. Time (see above for details).

Set the step increment size for the slider arrows. Must be an integer if Scale Type is Discrete.



Recording an Animation of your data:

You can stream data from disk by using the VCR type controls. Namely, hit the Play button.....

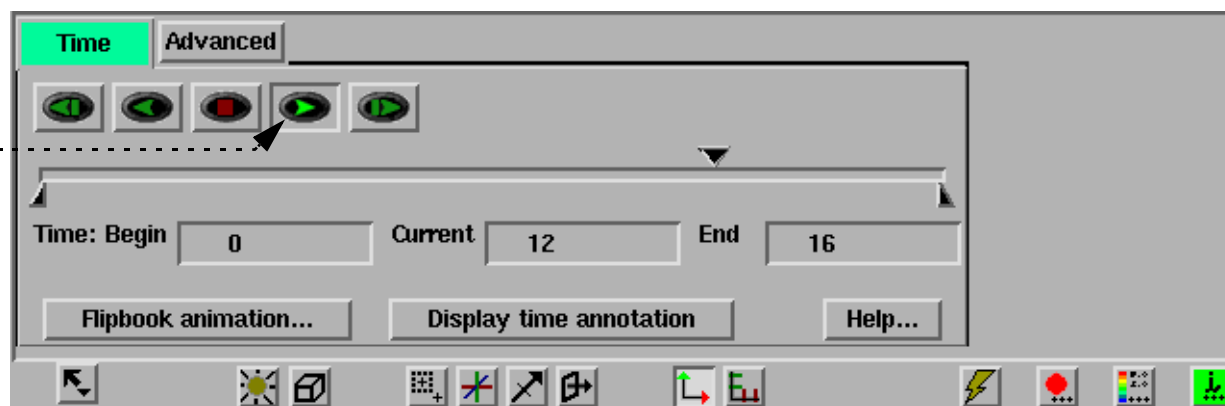

While this is occurring, the Record button will be brightly colored red and can be clicked to record the animation that is occurring.....

Note: This is similar to a flipbook animation loaded as images, but does not require additional workstation memory. Thus, it is a simple way to record an animation of your transient data.

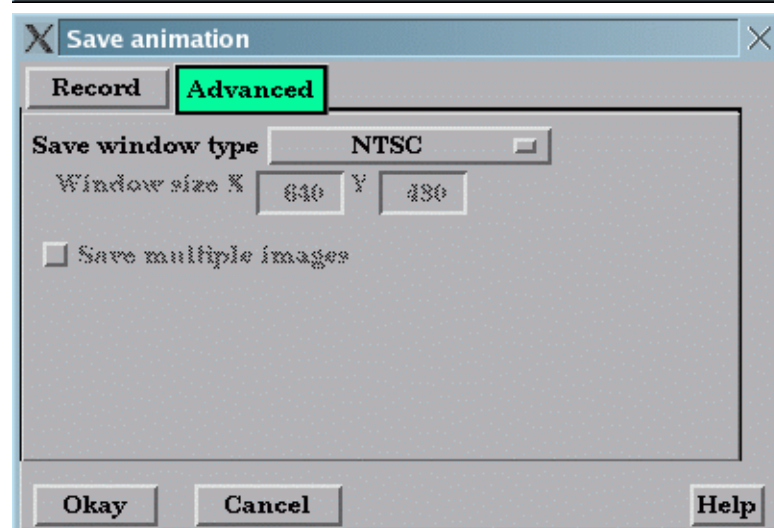
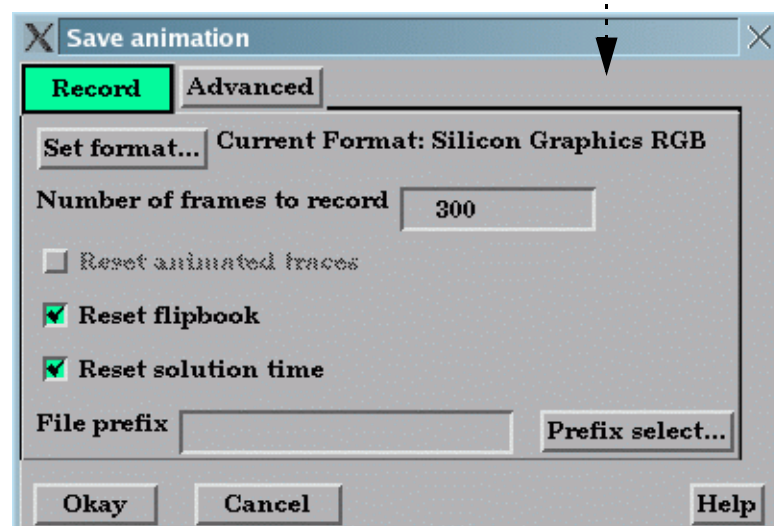

Available recording file formats are:

Apple PICT	Flipbook files saved as sequence of Apple PICT files.
JPEG	Flipbook files saved as sequence of JPEG files.
TIFF	Flipbook files saved as sequence of TIFF files.
PCL	Flipbook files saved as sequence of Page Control Language files.
PostScript	Flipbook files saved as sequence of PostScript files.
Silicon Graphics RGB	Flipbook files saved as sequence of SGI RGB files.
TARGA	Flipbook files saved as sequence of TARGA files.
CEI RGB with depth	Flipbook files saved as sequence of RGB files with depth.
EnVideo	Flipbook files are saved to EnVideo file.
MPEG1 / MPEG2	Flipbook files are saved to an MPEG file.
AVI	Flipbook files are saved to an AVI file.



ADVANCED USAGE

EnSight allows geometry and variables to behave in a transient manner on different timelines, i.e., a variable called Temperature can be defined at $t = 0., 3.,$ and $6.$ while a variable called Pressure can be defined at $t = 0., 2.,$ and $5.5.$ The Timeset Details button will bring up the Timeset Details dialog which allows the user to view the various timelines as well as specify how the variables will behave when they are not defined.

The EnSight case file defines the timesets (name and associated time values) and associates a timeset with each of the variables and geometry.

By default the Solution Time dialog will show a composite of all of the timesteps that exist across all of the timesets. This can, however be changed to show just the time values associated with a particular timeset.

In the Timeset Details dialog shown below, multiple timesets exist. Three timesets (from the Which Timeset(s) list) are selected and are thus shown in detail. The graphics for each timeset shows (a) the minimum and maximum overall time value, (b) white tick marks immediately under the timeline indicate the total (composite) time values available from the solution time dialog, (c) green tick marks indicating the time values defined for the timeset, (d) the current time value (indicated with the long green line) associated with the timeset.

The current solution time (as set in the Solution Time dialog).

Select the timeline to be viewed.

To modify all the timelines to behave the same way, select which range is to be modified, then select how they will be displayed.

The timeset can either be shown having a time range over the total number of time values or can be shown according to the timeset's range.

By default the Solution Time dialog shows the composite timeline. This button will modify the Solution Time dialog's Beg and End values to those of the selected timeset.

Shows the time value being used at the current time.

The timeset is used by the variables (or geometry) shown in this list.

When the current time (from the Solution Time dialog and indicated in the upper left corner of this dialog) is set to a value less than what is available for this timeline, use the Nearest value or make the variable Undefined.

When the current time (from the Solution Time dialog and indicated in the upper left corner of this dialog) is set to a value that does not exist for this timeline, Interpolate between defined time values, use the Left, Right, or Nearest value, or make the variable Undefined.

When the current time (from the Solution Time dialog and indicated in the upper left corner of this dialog) is set to a value greater than what is available for this timeline, use the Nearest value or make the variable Undefined.

SEE ALSO

[How To Load Transient Data](#), [How To Animate Transient Data](#)

User Manual: [Flipbook Animation](#)





INTRODUCTION

Vortex cores are centers of swirling flow where the velocity is parallel to the vorticity. For a more complete description refer to the User Manual section below.

BASIC OPERATION

1. Select the parent part.

2. Select the Vortex Core icon on the second row of icons.

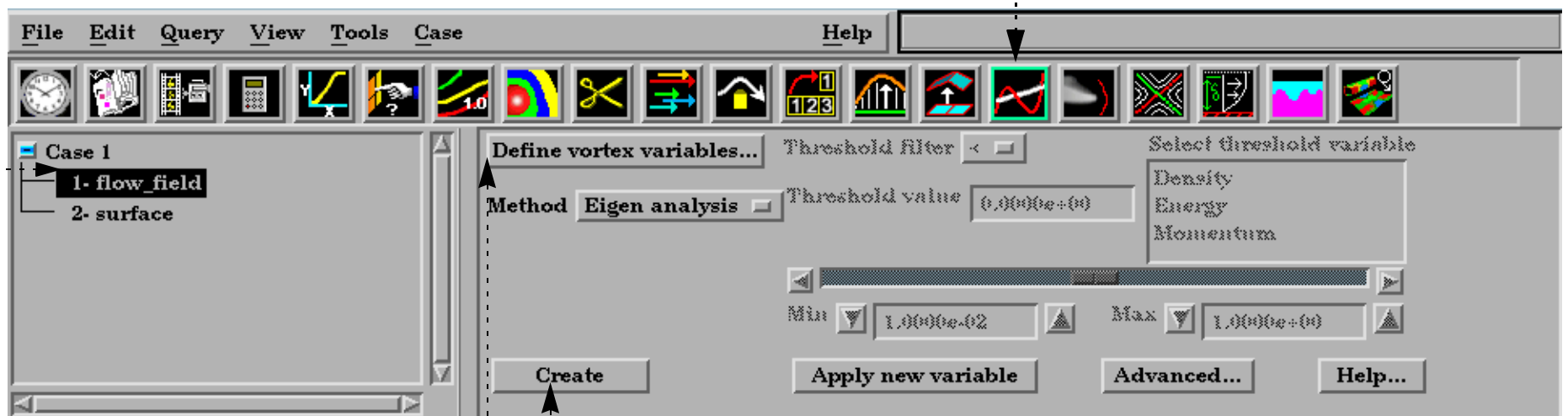

3. Bring up the Vortex Core Variable Settings dialog by clicking here.

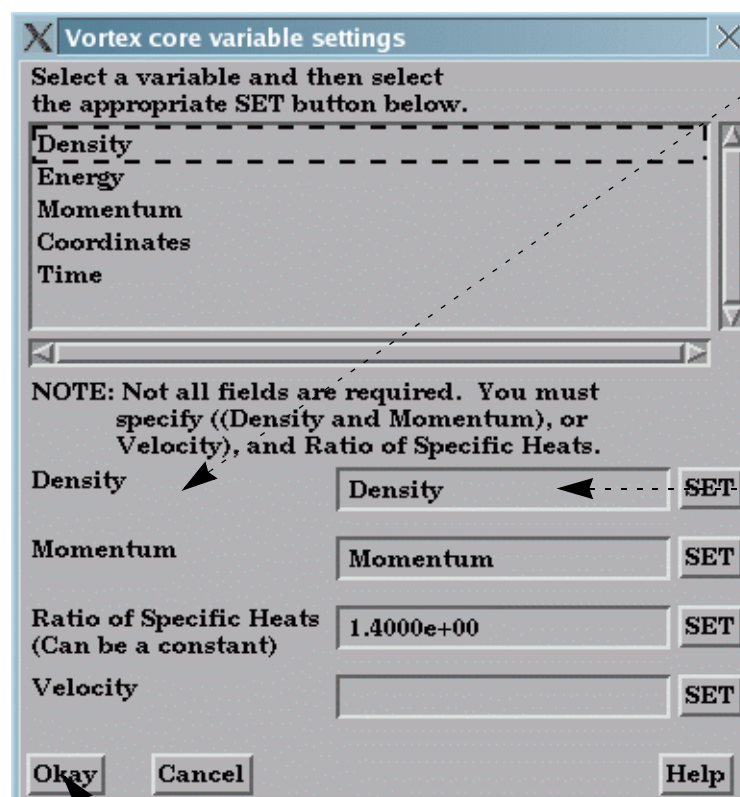

4. Define either (Density and Momentum) or Velocity, as well as the Ratio of Specific Heats.

The variables can be set by either typing them into the fields, or selecting them from the list above and clicking the Set button.

5. Click Okay to finish the variable setup.

6. Click Create.



ADVANCED USAGE

The resulting vortex core lines can be filtered by the vortex core strength or by any other active variable.

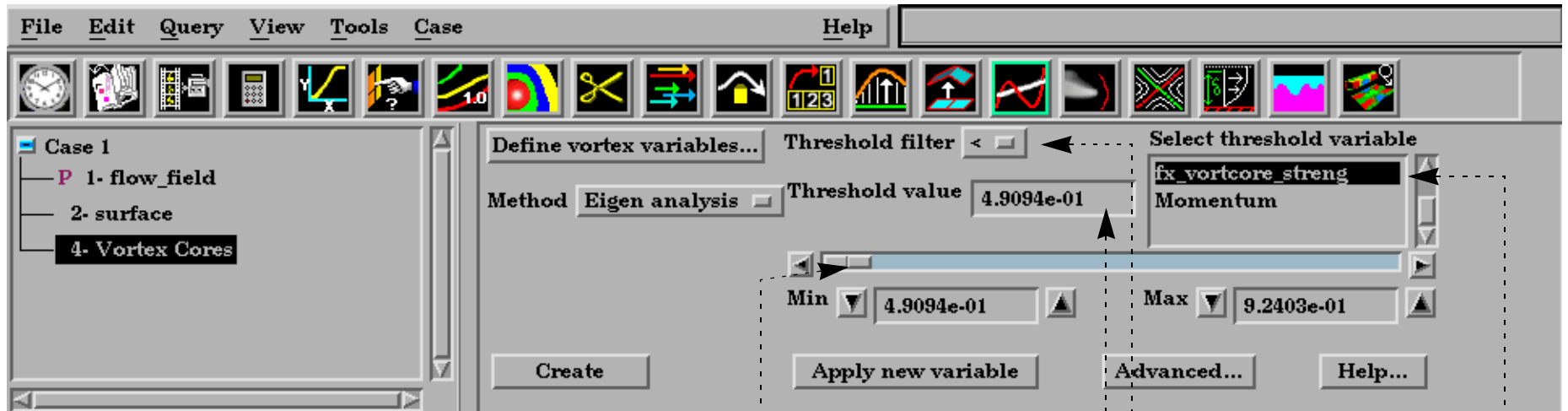

1. Select the variable to filter by.
2. Set the Threshold filter to remove the portion of the vortex core that is larger or less than the specified threshold value.
3. Enter a threshold value
- or -
3. Slide the slider to a new threshold value.

OTHER NOTES

Extract Vortex Cores does not work with more than one case.

SEE ALSO

User Manual: [Vortex Core Create/Update](#)

INTRODUCTION

Separation and attachment lines are created on any 2D surface and show interfaces where flow abruptly leaves (separates) or returns (attaches) to the surface. For a more complete description refer to the User Manual section below.

BASIC OPERATION

1. Select the 2D parent part.
2. Click the Separation/Attachment part icon.

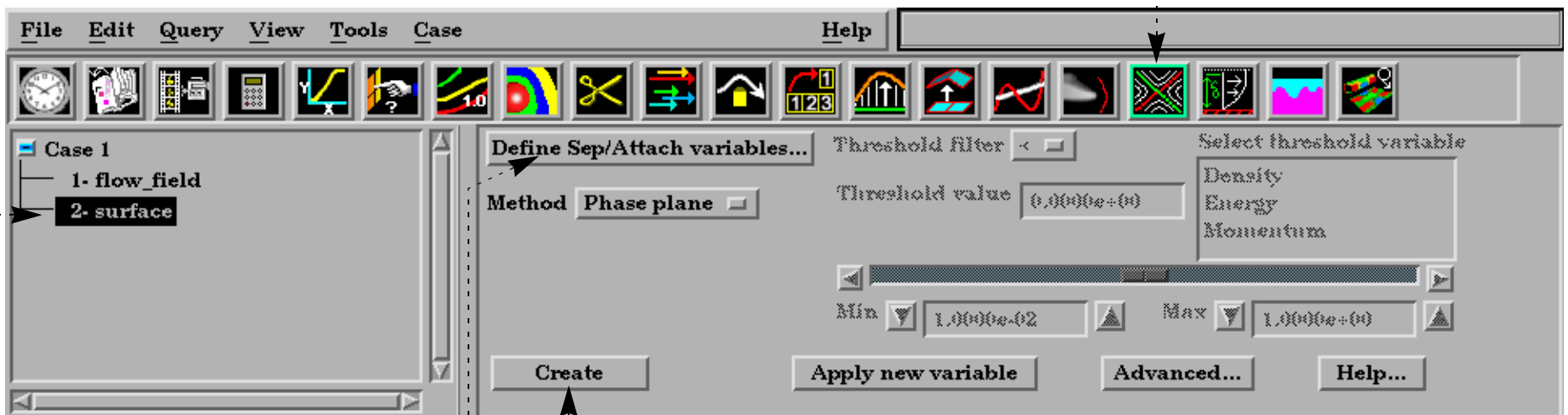

3. Bring up the dialog defining the necessary variables by clicking here.

4. Define either Density and Momentum or velocity, as well as the Ratio of Specific Heats.

The variables can be set by either typing them into the fields or by selecting them from the list above and clicking the Set button.

5. Click Okay to finish the variable setup.

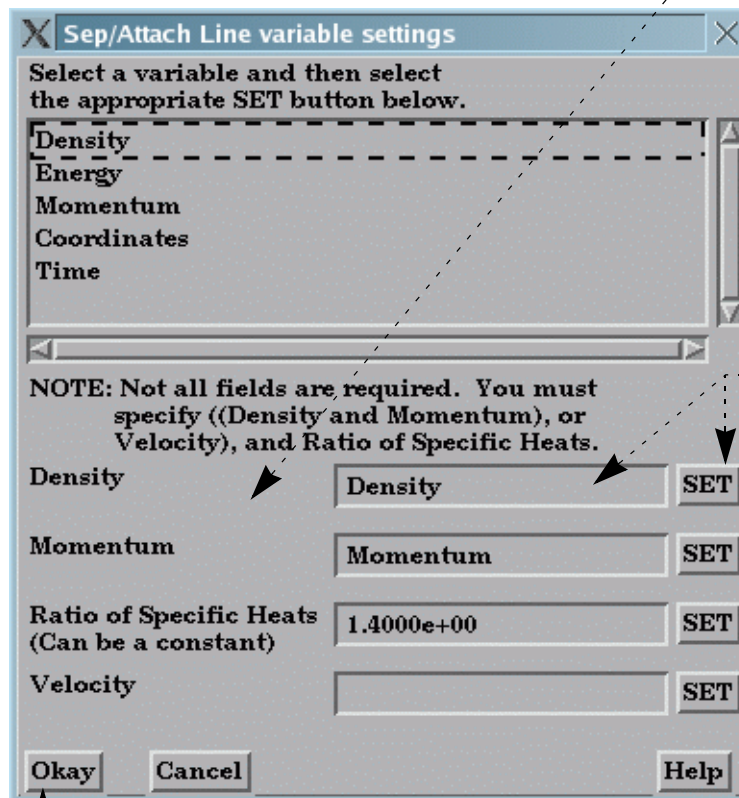

6. Click Create

This will create two parts - one each for the separation and attachment lines. You can modify the visual attributes of these parts separately, but when you change any creation attribute, both parts will be modified.



ADVANCED USAGE

The resulting separation/attachment parts can be filtered by the `fx_sep_att_strength` variable or by any other active variable.

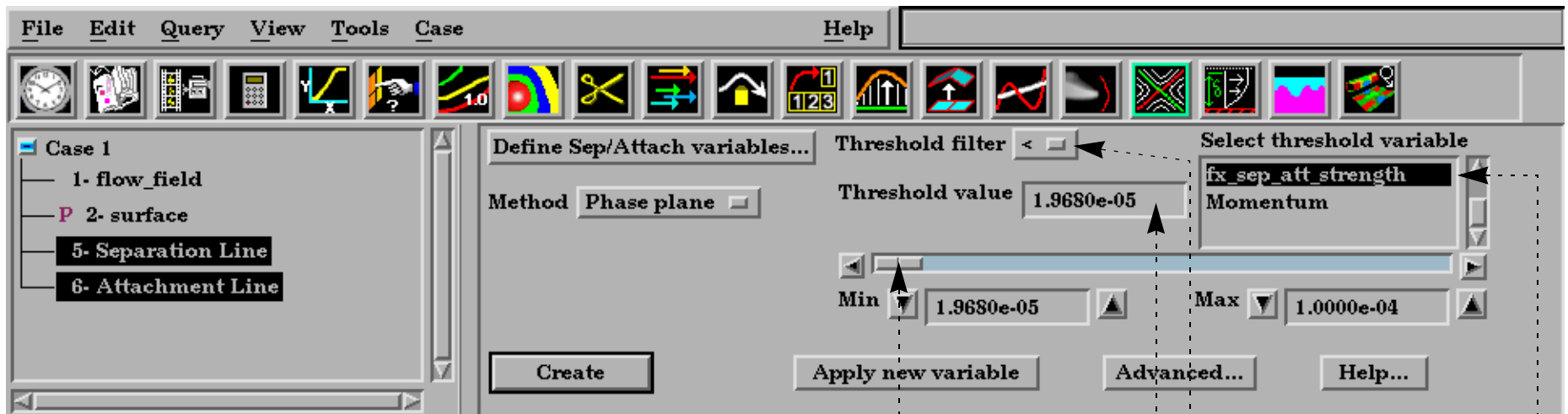

1. Select the variable to filter by.
2. Set the Threshold filter to remove the portion of the separation/attachment line that is larger or smaller than the specified threshold value.
3. Enter a threshold value
- or -
3. Slide the slider to a new threshold value.

OTHER NOTES

The separation and attachment parts are linked together with regard to their creation attributes, i.e. when one is modified the other is also. Further, when one is deleted the other is also deleted.

Separation and Attachment feature extraction only works with one case.

The separation and attachment line parts should generally not interfere visually with the 2D parent parts they lie on (as long as the preference for graphics hardware offset is on - see View Preferences), but they may interfere if printed. In either case you can apply a display offset manually to avoid the interference in the Feature Detail Editor for the part. The display offset will be in the direction of the parent surface normal.

SEE ALSO

User Manual: [Separation/Attachment Lines Create/Update](#)



INTRODUCTION

Shock surfaces and regions help visualize shock waves in 3D (trans/super-sonic) flow. For a more complete description, refer to the User Manual section below.

BASIC OPERATION

1. Select the parent part.
2. Click the Shock Surface/Region icon.

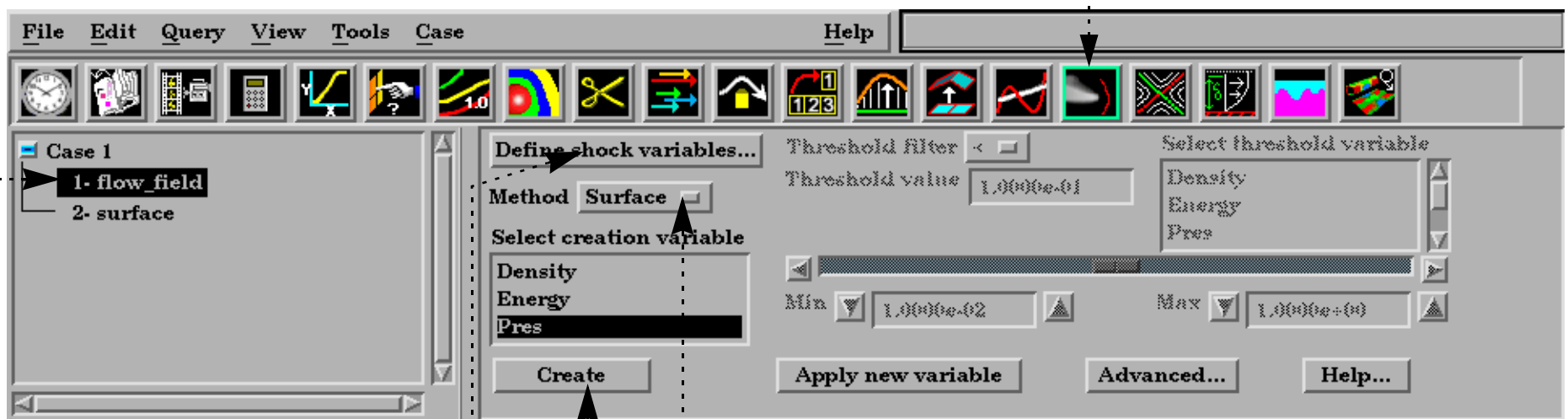

3. Bring up the dialog defining the necessary variables by clicking here.

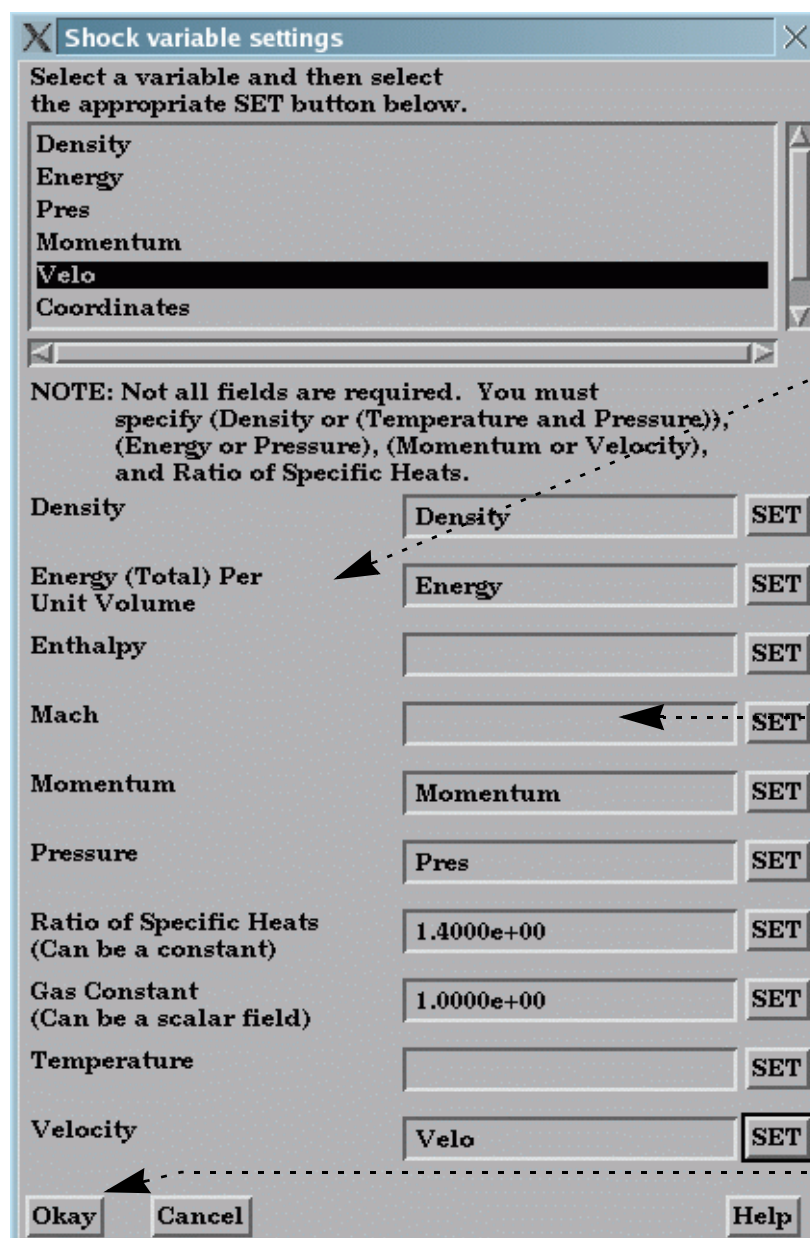

4. Define either Density or (Temperature and Pressure), (Energy or Pressure), (Momentum or Velocity), and Ratio of Specific Heats.

The variables can be set by either typing them into the fields, or selecting them from the list and clicking the Set button.

5. Click Okay to finish the variable setup.

6. Choose Region or Surface.

7. Click Create.



ADVANCED USAGE

The resulting shock can be filtered by any of the threshold variables

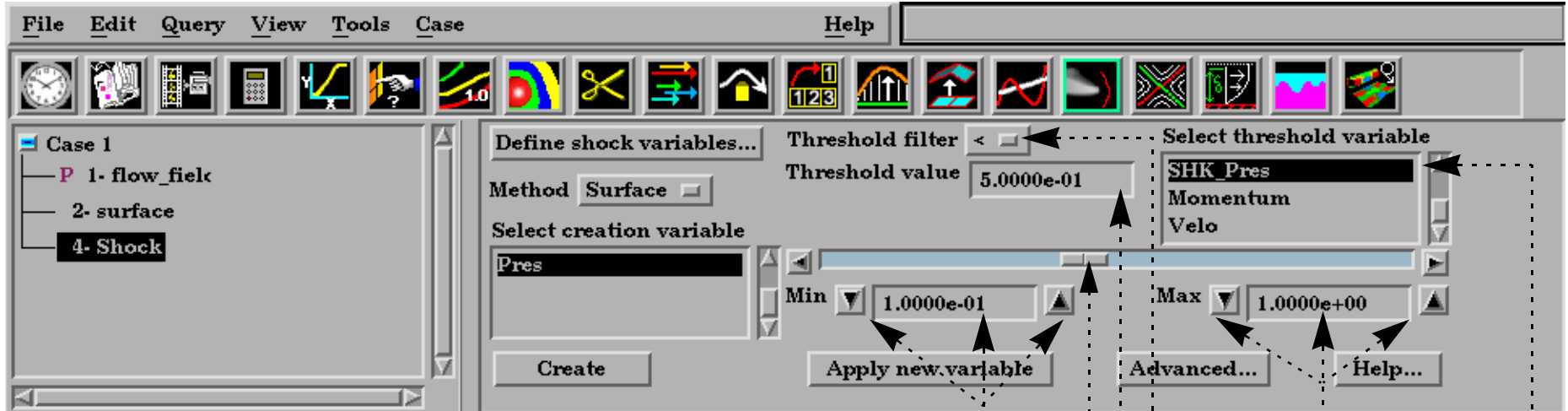

1. Select the variable to filter by.
2. Set the Threshold filter to remove the portion of the shock surface or region that is greater or less than the specified threshold value.
3. Enter a threshold value
- or -
3. Slide the slider to a new threshold value
4. The shock is usually defined in a very narrow band, so the slider min/max values may need to be adjusted by either entering new values in the min/max fields, or clicking on the up/down buttons to change by an order of magnitude.

OTHER NOTES

See [Other Notes](#) in the Shock Surface/Region Create/Update section of the User Manual for options on how to pre-filter flow field regions, and/or post-filter shock regions via a specified mach number. Also to apply the transient correction term for moving shocks when using the shock Region method.

Shock Surface feature extraction does not work with multiple cases.

SEE ALSO

User Manual: [Shock Surface/Region Create/Update](#)



Create Material Parts

INTRODUCTION

A Material Part can be created as either a domain or an interface.

A material Domain is a solid region (or regions) composed of one or more specified materials. Parts with 2D elements yield 2D material elements, and parts with 3D elements yield 3D material elements.

A material Interface is a boundary region (or regions) between adjacent materials composed of at least two or more specified materials. Parts with 2D elements yield 1D material elements, and parts with 3D elements yield 2D material elements.

The Material Part feature can be used to isolate specified elemental regions of interest in data sets with material fractions.

BASIC OPERATION

For Material Domain:

1. Click the Material Parts creation icon.

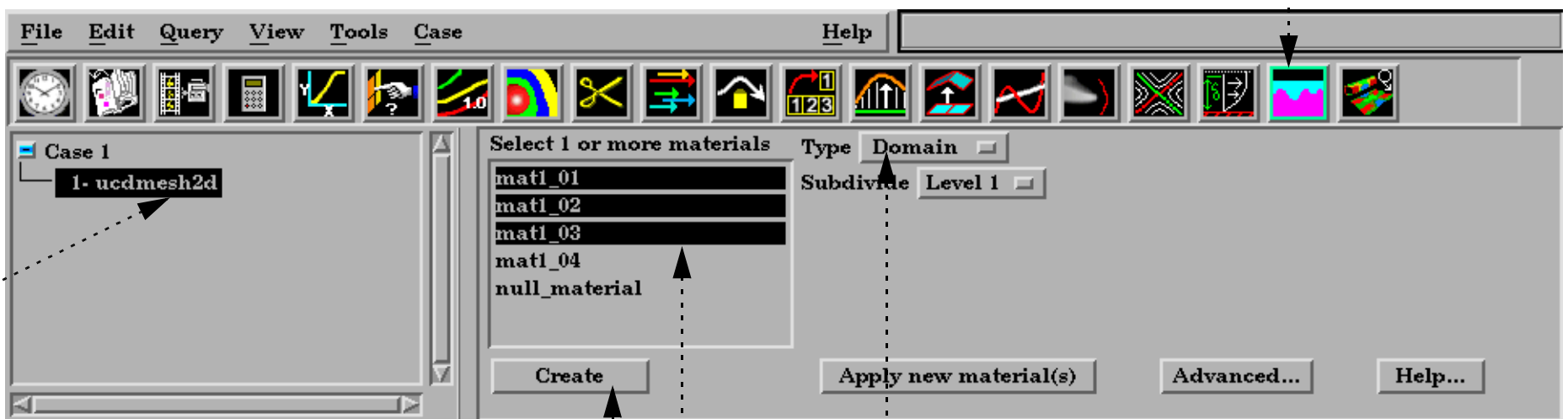

2. Select the parent model part(s).
3. Set Type to Domain.
4. Select 1 or more materials.
5. Click Create.

For Material Interface:

1. Click the Material Parts creation icon.

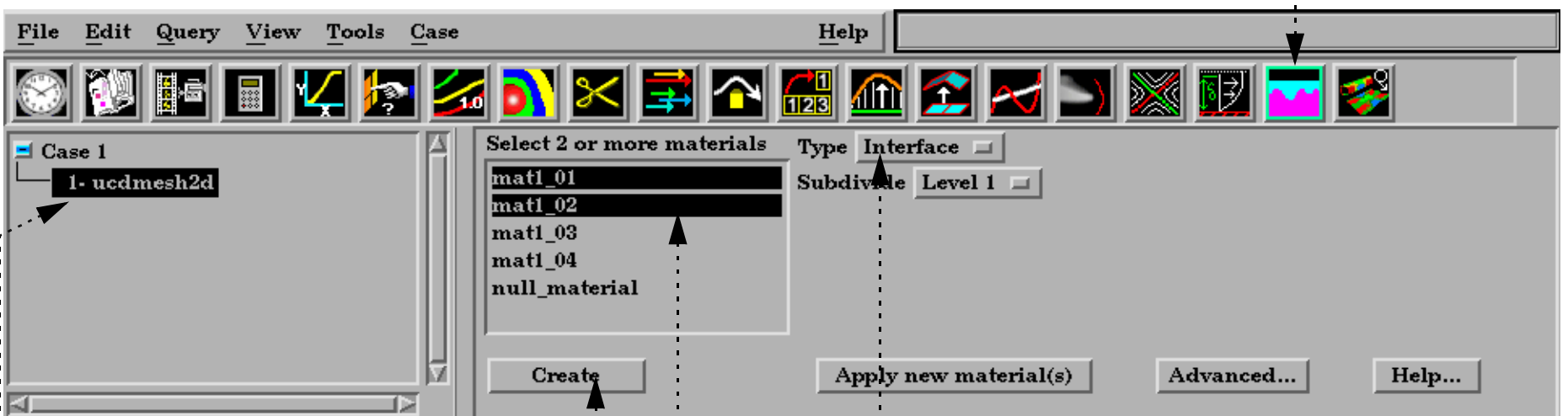

2. Select the parent model part(s).
3. Set Type to Interface.
4. Select 2 or more materials.
5. Click Create.



ADVANCED USAGE

Increased Element Resolution

You can increase the element resolution of the Material Part by increasing the Subdivide option from Level 1 to either Level 2 or Level 3:

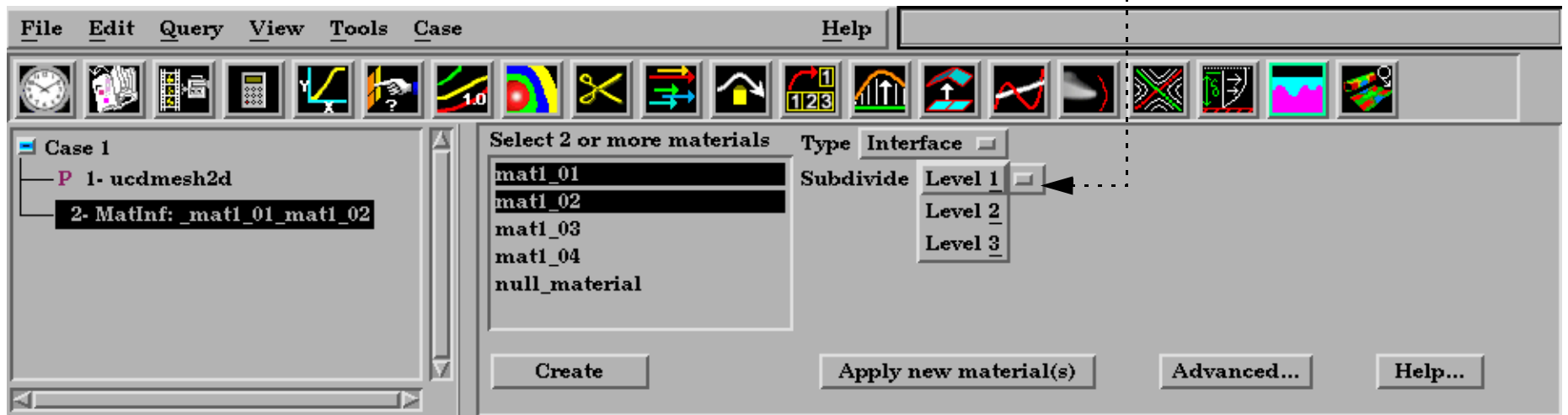

Each 3D (or 2D) part element is first decomposed into tetrahedrons (or triangles) before it is processed. Level 1 simply processes each of these decomposed elements. Level 2 subdivides each of these decomposed elements into 3 sub-tetrahedrons (or sub-triangles). Level 3 subdivides each of these decomposed elements into 6 sub-tetrahedrons (or sub-triangles). Each subdivided element is then processed.

SEE ALSO

User Manual:

[Material Parts Create/Update](#)

In [Section 11.1, EnSight Gold Casefile Format](#), see [EnSight Gold Material Files Format](#)



Remove Failed Elements

INTRODUCTION

A variable can be used within EnSight as a means of removing elements that have “failed”. This can be something as simple as a variable with two states (one state to indicate the element is failed, and the other state to indicate that the element is not failed), or it can be a variable of values (such as a Von Mises stress/strain) for which you specify limiting values and conditions for failure. The variable used must be a per-element variable. Also, this operation can only be performed on model parts. So if its effect is desired on created parts, such as clip planes or isosurfaces, one should apply this operation to the model parent parts of the desired created parts.

BASIC OPERATION

To use a per-element variable for removing failed elements:

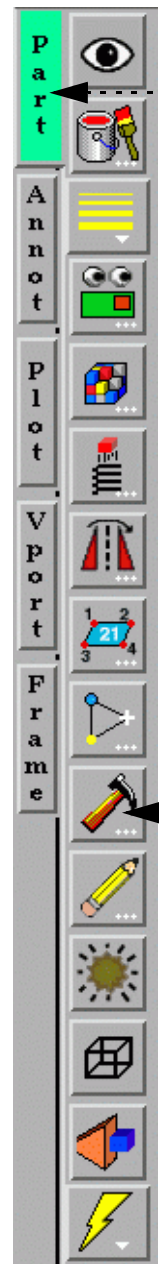

1. Select the model part(s) to use.
2. Select Part Mode.
3. Click on the Failed elements button.
4. Select the per-element variable to use for failure (in this example we use Failure_Stress).
5. Set the desired condition(s) and value(s) (in this case we fail if the Failure_Stress is greater than 0.70)
6. Click Apply

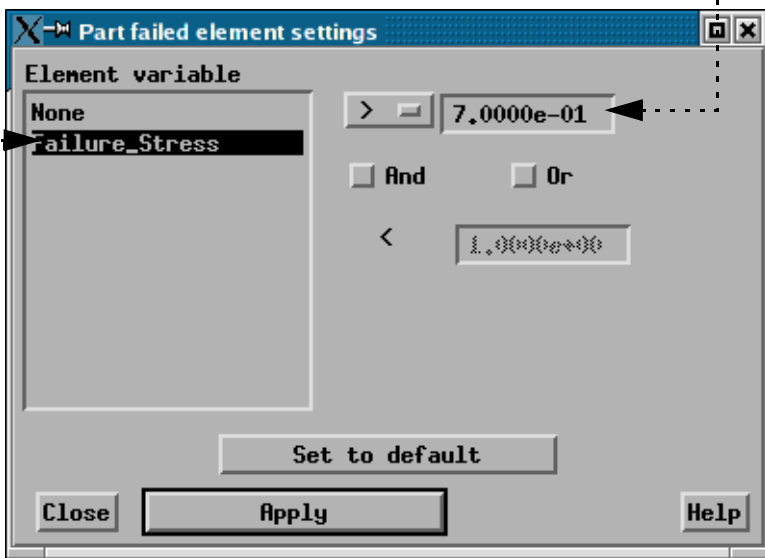

Those elements which satisfy the failure criteria will be removed from the model.

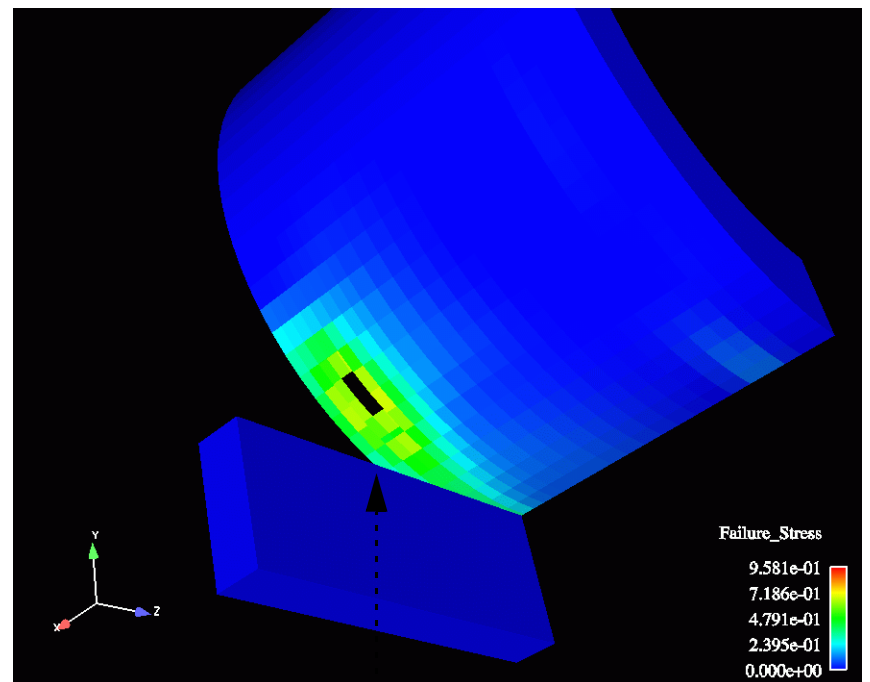
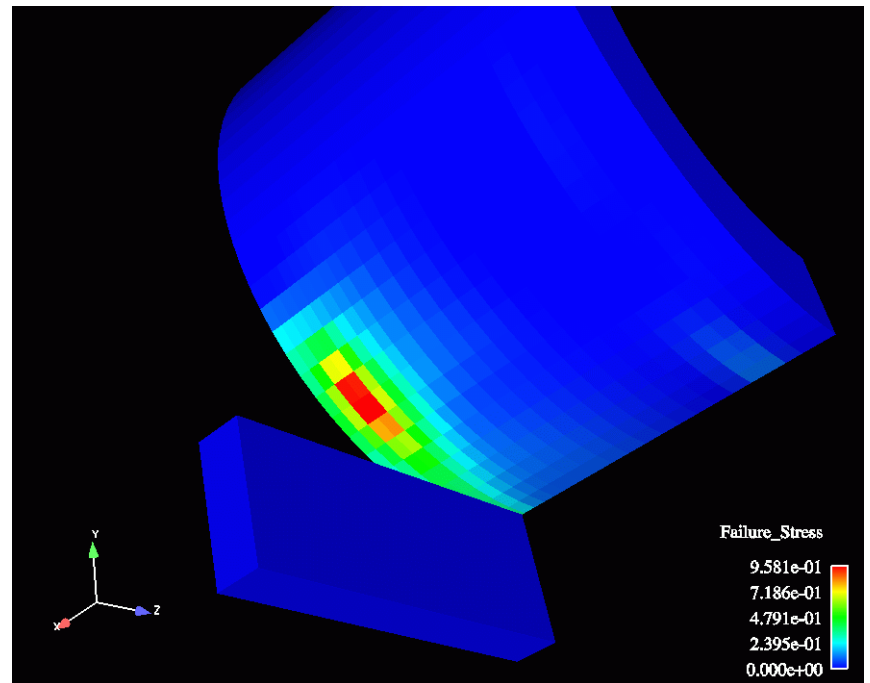



ADVANCED USAGE

EnSight's User-defined reader API is capable of dealing with designated failure variables and the failure values and conditions. Thus, a reader can be set up to use failure conditions that solvers provide and automatically apply the failed element operations for you. An example of this is the LS-DYNA3D reader provided with EnSight.

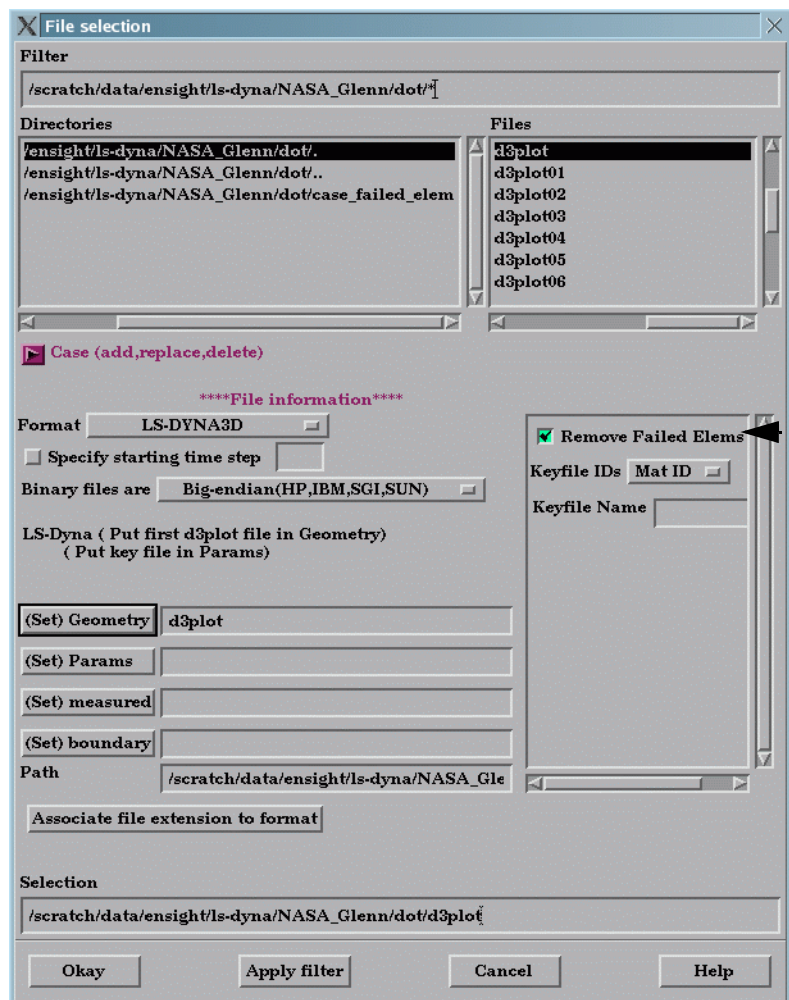

Note the extra GUI option provided by this reader, entitled: "Remove Failed Elements".

By checking this option, a "Delete_Flag" variable is created, and the failed element feature of EnSight will be automatically on - with the conditions and values set that will remove the failed elements that the solver flagged as such. (Which for LS-DYNA3D is a value equal to 0.0 in the Delete_Flag variable).

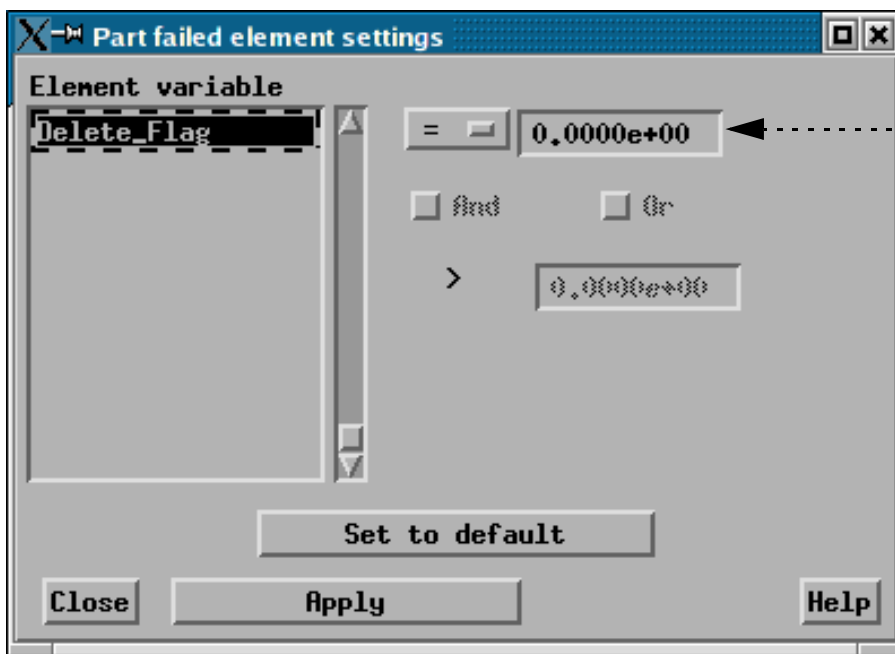

SEE ALSO

[How-To Read User Defined](#)

User Manual: [Failed Elements](#)



Do Element Blanking

INTRODUCTION

EnSight allows you to pick elements in the model and make them disappear - "blank them out". This may be desirable if you want to peek inside of certain parts or remove portions of a part (without making the entire part invisible or transparent). Element blanking is a temporary state that can easily be "cleared" - making the elements visible again.

BASIC OPERATION

Using picking to do element blanking:



1. Place the mouse pointer over the element you wish to blank out and perform the picking action which does element blanking.

By default this action is double clicking of the right mouse button.

You will see the element under the mouse disappear as you do the picking.

2. To cause the elements to reappear, click the Element blanking/visibility icon and click the clear button in the dialog which comes up.

Note, in order for the element blanking to work, the Element blanking allowed toggle needs to be on (the default).

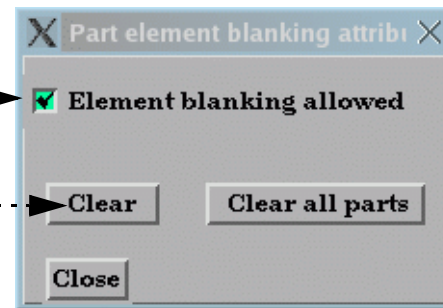
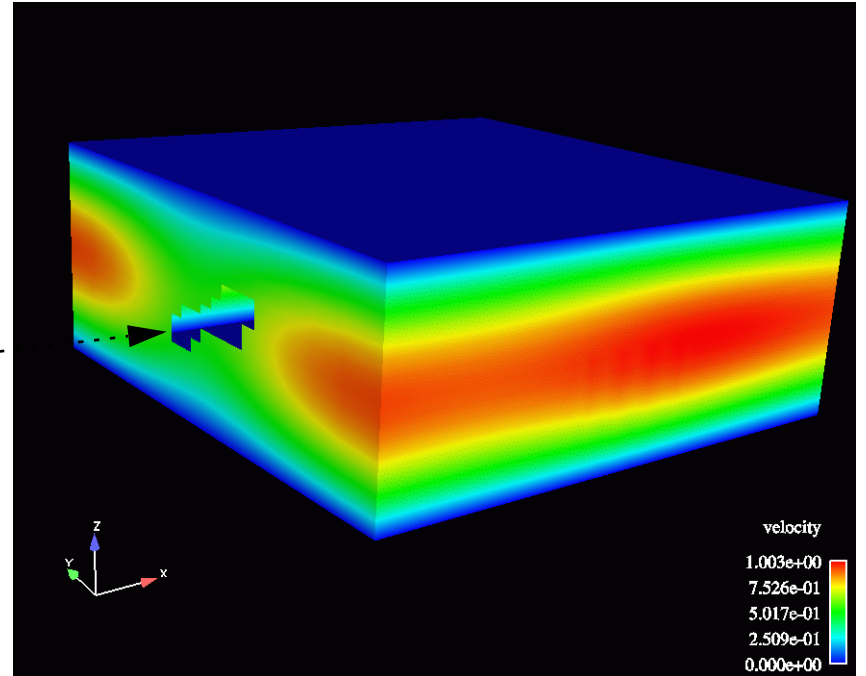

Note that the button and clicking action that performs the desired pick action is actually dependent upon the settings in Edit > Preferences > Mouse and Keyboard.

For example, given the settings shown, one could also set the pick action to "Pick element(s) to blank" and either use the keyboard "P" key or double clicking of the left mouse button.

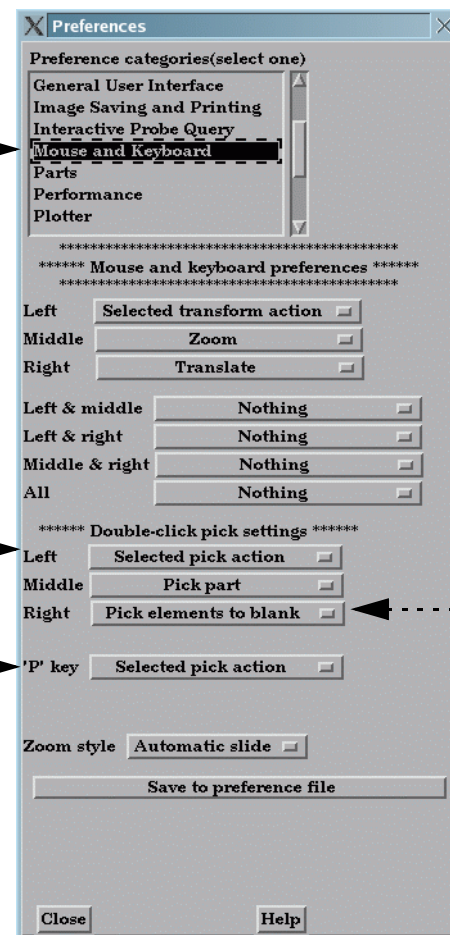
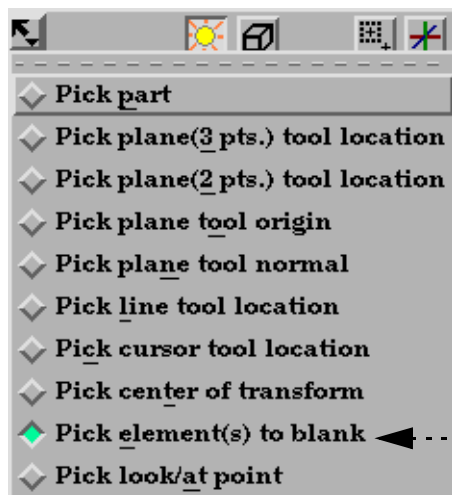

Note the default for element blanking.



The selection tool can be used to do element blanking on a larger scale:

1. Select the part(s) on which to do element blanking.
2. Click on the Selection tool icon to turn on the tool.
3. Position the tool as desired.
4. Click on the element blanking symbol at the upper left of the tool.

Note, in order for this to work, the Element blanking allowed toggle needs to be on (the default).

To undo the blanking, click the Clear or Clear all parts button.

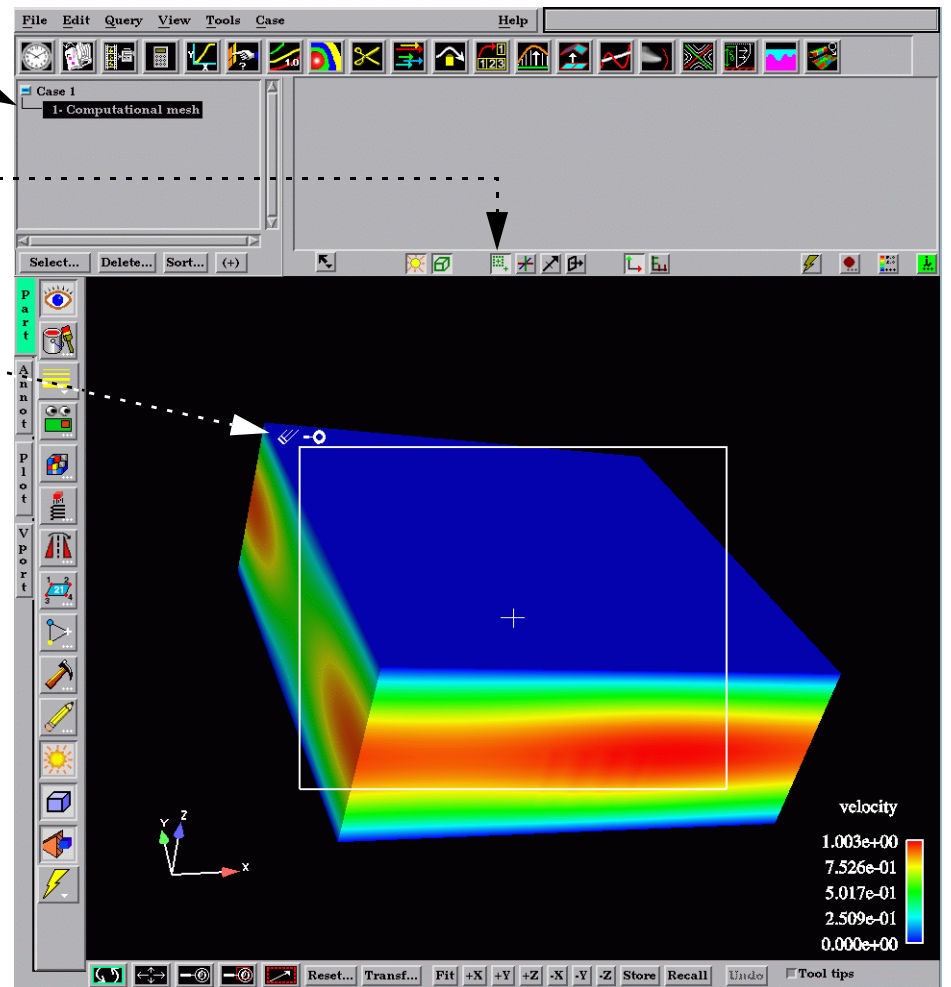

Results in the following:

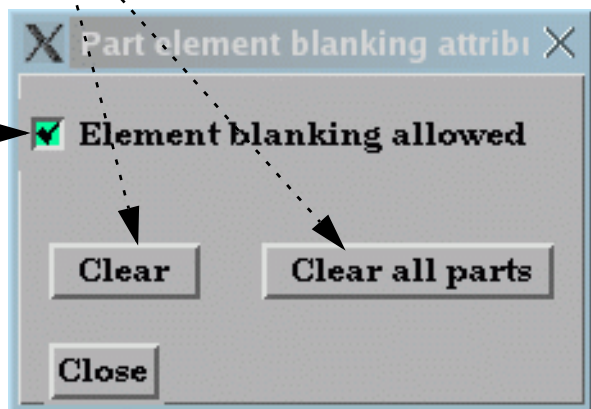
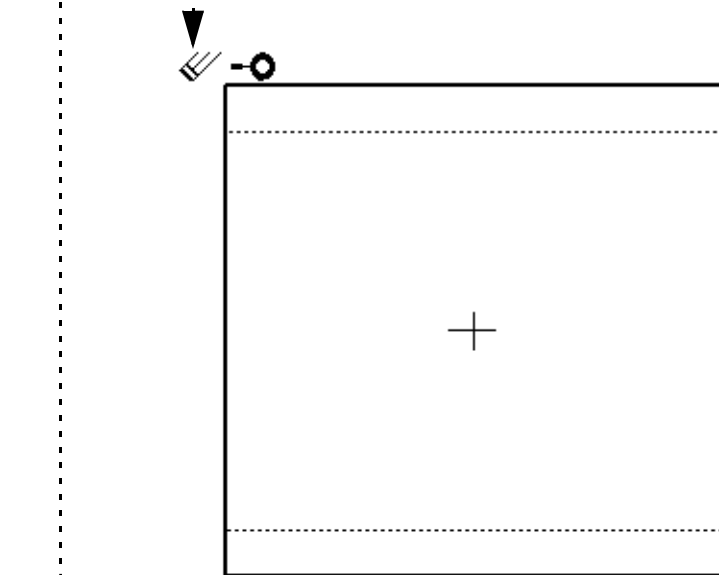
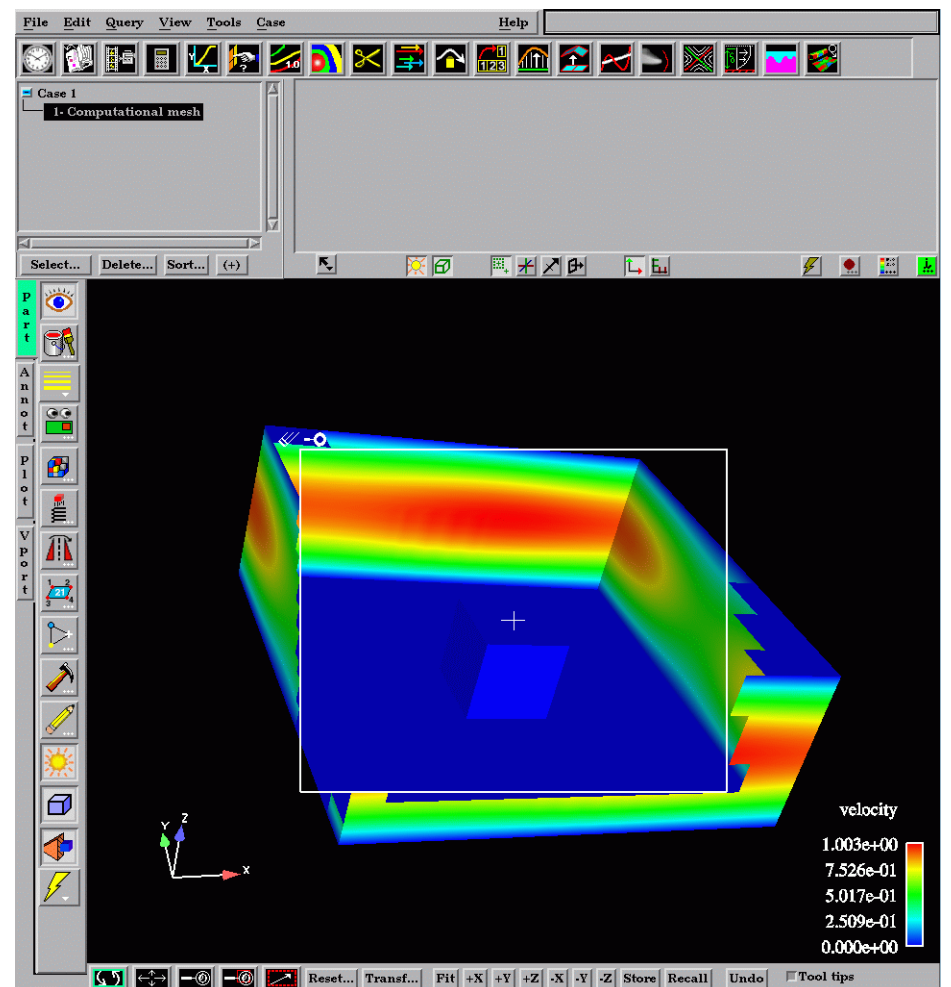

SEE ALSO

[How To Use Selection Tool](#)

User Manual: [Element Blanking](#)



Create and Manipulate Variables
Activate Variables

INTRODUCTION

When a results dataset is read into EnSight, associated variables are noted and listed in the Main Variables List. However, a variable will remain *deactivated* (not loaded into memory) until some operation requires it or it is explicitly *activated* (read into memory).

If an active variable is no longer required, you can deactivate it and free the associated memory.

BASIC OPERATION

Variable Activation

In most instances, variables are automatically activated as required. For example, if you create a contour using a deactivated variable, EnSight will automatically activate the variable prior to creating the contour.

You can also activate variables explicitly using the Feature Detail Editor for Variables.

1. Open the Feature Detail Editor for Variables.

You can open this dialog in several ways. You can do Edit > Variables editor... from the main menu...

or

double click the Color/transparency icon in the Part mode icons

or

after single clicking the Color/transparency icon, you can double click on one of the variables in the list of the Part color, lighting, & transparency dialog.

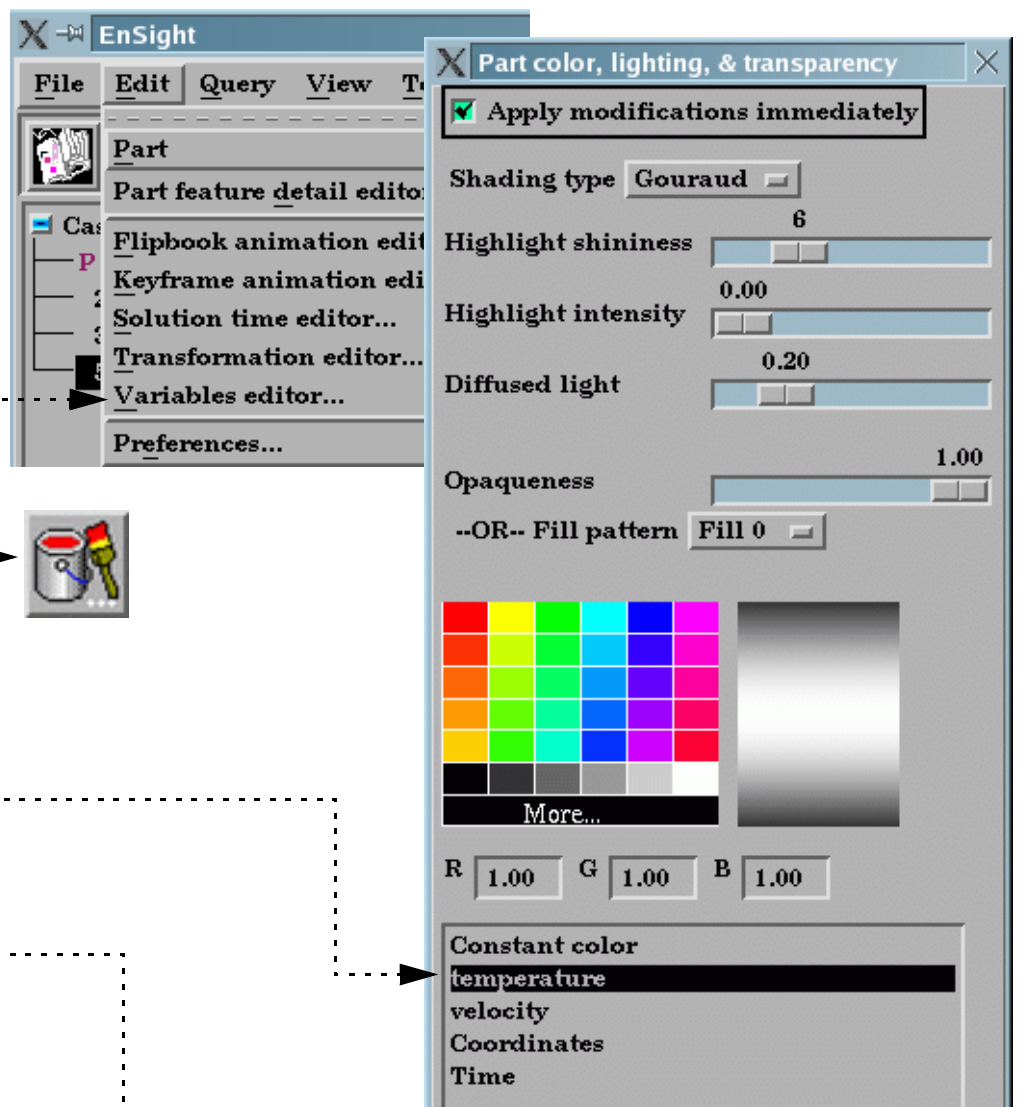

2. Select the variable(s) you wish to activate.

3. Click the Activate button.

OR

2. Click the Activate All button to activate all variables in the list.

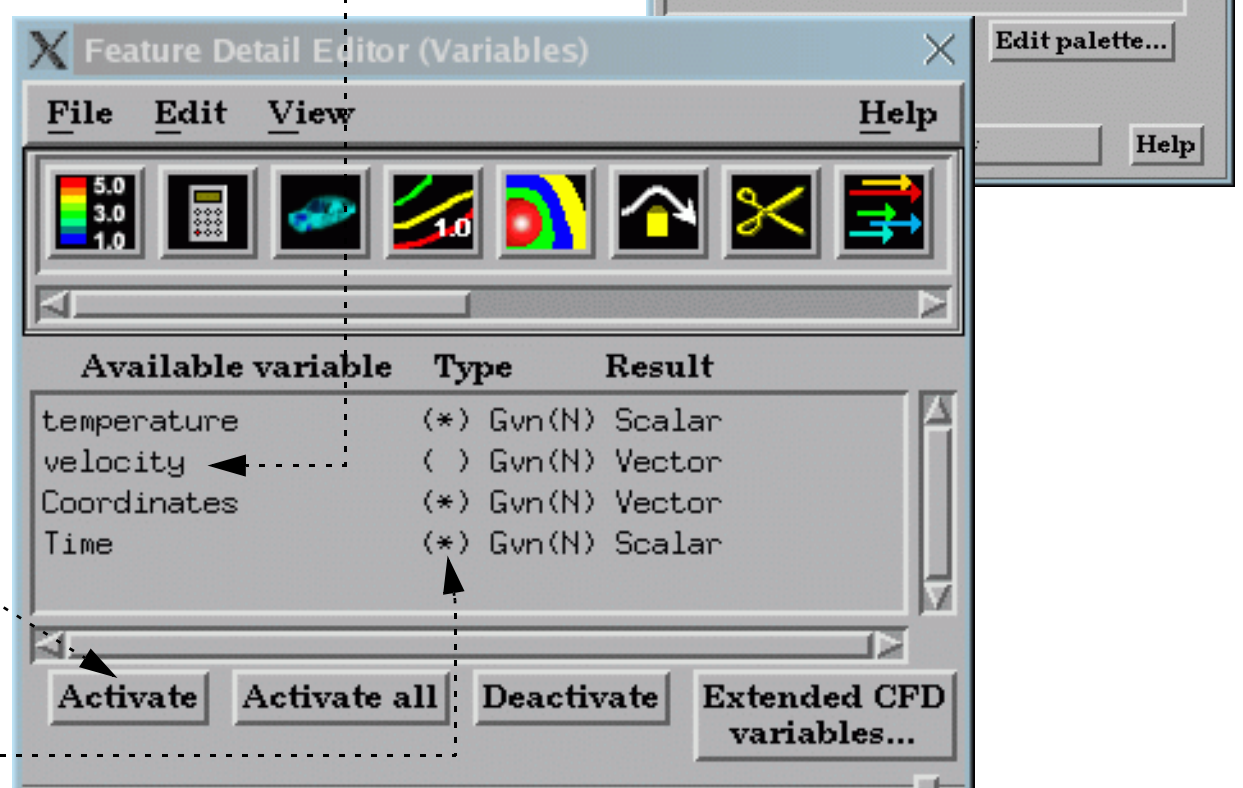

The (*) in the variable listing indicates that the variable is currently loaded.



Variable Deactivation

Variables are never deactivated automatically. To deactivate a variable:

1. Open the Feature Detail Editor for Variables.

You can open this dialog in several ways. You can do Edit > Variables editor... from the main menu, or **double click** the Color/transparency icon in the Part mode icons, or after single clicking the Color/transparency icon, you can double click on one of the variables in the list of the Part color, lighting, & transparency dialog.

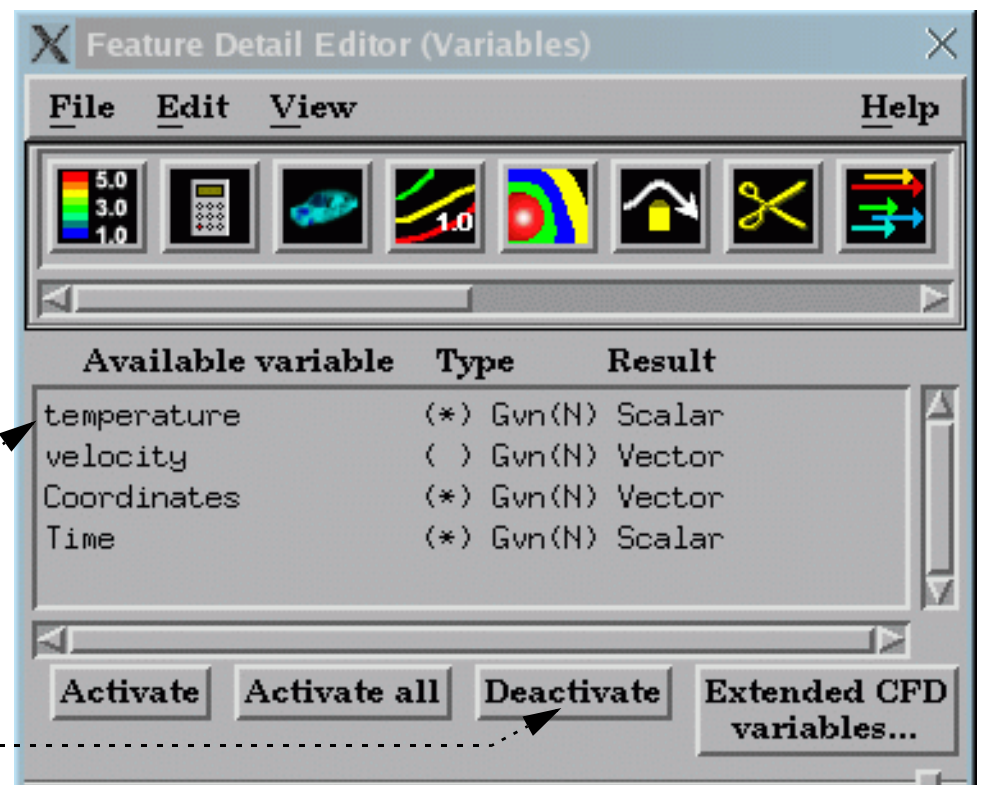

2. Select the variable(s) you wish to deactivate.....

3. Click the Deactivate button.

Note that variable deactivation can result in the modification or deletion of parts. If this is the case, you will be asked to confirm the deactivation. A part could be modified if it used the deactivated variable for coloring. A part could be deleted if it was based on the deactivated variable (such as a contour or an isosurface).

SEE ALSO

[How To Edit Color Palettes](#), [How To Create New Variables](#)

User Manual: [Variable Selection and Activation](#)



Create New Variables

INTRODUCTION

EnSight provides a powerful capability to derive new variables from existing variables and parts. For example, in a fluids dynamics problem, if you have momentum, density, and stagnation energy you can calculate temperature, Mach number, pressure, or velocity. In addition to the built-in functions, you can also compose your own functions using the equation editor in conjunction with previously defined variables.

This article is divided into the following sections:

- [Introduction](#)
- [Variable Creation](#)
- [Examples of Expressions](#)
- [Built-in Function Reference](#)
- [Extended CFD Variables](#)

BASIC OPERATION

Introduction

EnSight provides five distinct types of variables:

Constant	A constant variable is a single value. Constants do not vary across a part although a constant can vary over time. Examples include <code>Analysis_Time</code> , <code>Temperature[123]</code> (the value of temperature at node 123), <code>Stress{3}[321]</code> (the value of stress at node 321 at time step 3), or the value of a function that produces a constant (e.g. Area).
Scalar	A scalar variable is a set of values: one for each node or element of the applicable part(s). Examples include <code>Pressure</code> , <code>Velocity[Z]</code> (the Z component of velocity), <code>Stress{3}</code> (the value of stress at time step 3), or the value of a function that produces a scalar (e.g. Flow)
Vector	A vector variable is a set of values: three (the X,Y,Z components) for each node or element of the applicable part(s). Examples include <code>Velocity</code> , <code>Velocity{3}</code> (the value of velocity at time step 3), <code>Coordinates</code> (a given variable equal to the XYZ coordinate at a node), or the value of a function that produces a vector (e.g. Vorticity).
Tensor	A tensor variable is a set of values: six (if symmetric) or nine (if asymmetric), for each node or element of the applicable part(s). Tensor variables can be represented by Tensor Glyphs directly, and within the variable calculator eigenvalues, eigenvectors, determinant, VonMises or Tresca, etc. can be computed.
Complex	A complex variable, which within EnSight can be either scalar or vector, includes the real and imaginary portions of the values. The variable calculator allows the user to compute things like modulus, argument, transient response, etc.

Variables are either *given* (read from the dataset or automatically provided by EnSight) or *computed* (derived from existing variables during an EnSight session). The variable type and whether it is given (shown as “Gvn”) or computed (shown as “Cmp”) are shown in the Variables list in the Feature Detail Editor for Variables. If you have any element-based variables in a model, the variable names in the Main Variables list will be preceded by “(E)” for element-based or “(N)” for node-based.

Every non-constant variable (both given as well as computed) has an associated color palette that defines the mapping from variable values to color. These palettes can be edited to change the mapping (see [How To Edit Color Maps](#) for details). The value of a constant variable can be displayed as a text string in the Graphics Window (see [How To Create Text Annotation](#) for details).

For time-dependent data, calculated variables will automatically recalculate when the current time step is changed.





Variable Creation

Derived variables are easily created using the **Feature Detail Editor Variable Calculator**. To create new variables:

1. Double-click the Variable Calculator icon in the Feature Icon bar to open the Feature Detail Editor (Calculator).



3. Select the desired function from the General list or the Math list.

When you select a function, the Variable Name field (at the top of the section) is loaded with the name of the function. This will be the name of the variable as seen in the Main Variables list. You can change this name by entering a new value (and pressing return).

A description of the function parameters appears in the feedback section, as well as instructions for properly composing the required parameters.

The expression is built in the Working Expression section. As you insert parameters, they are automatically added to the expression and the instructions for the next parameter will appear. Parameters can be inserted as follows:

Parts: by selecting the desired part(s) in the Main Parts list (and clicking Okay) or by entering the part number directly in the Working Expression area. Note that the place holder "plist" appears in the expression denoting the list of currently selected parts.

Variables: by clicking on the desired variable in the Active Variables list.

Constants/other: by typing the desired constant or other text directly into the Working Expression or by clicking the desired item in the Calculator keypad.

4. Follow the instructions to build the desired expression and then click Evaluate.

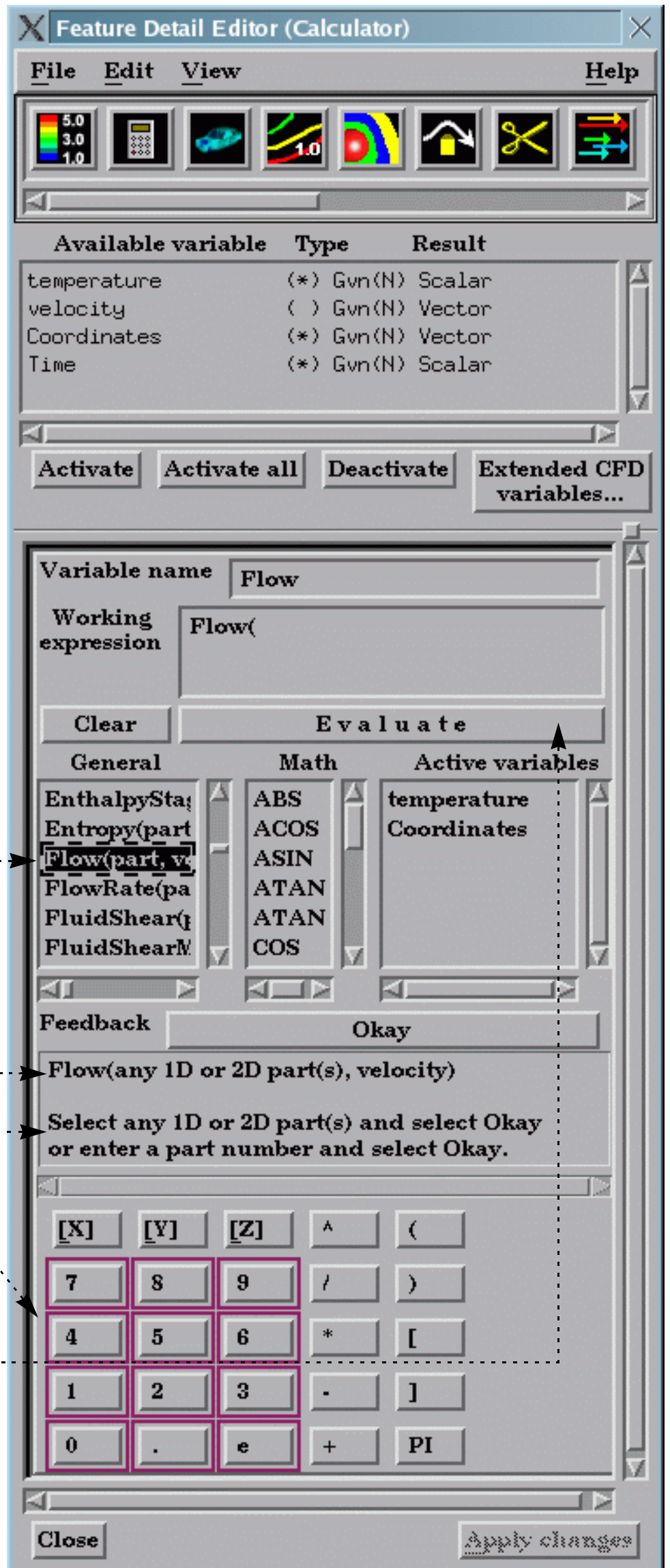



Examples of Expressions

The following examples demonstrate usage of the variable calculator. In each case, first enter a name in the Variable Name field and click in the Working Expression area to activate it. The examples assume that Analysis_Time (a given constant variable if the dataset is transient), pressure, density, and velocity are all given variables.

Expression	Description and How to Build
<code>-13.5/3.5</code>	A simple constant. To build, either type the text on the keyboard or click in the Calculator keypad.
<code>Analysis_Time/60.0</code>	A constant variable. Assuming the solution time was given in seconds, this expression will provide a variable giving the time in minutes. To build, select <code>Analysis_Time</code> from the Active Variable list and either type or click <code>/60.0</code>
<code>velocity*density</code>	Momentum – a vector variable. To build, select <code>velocity</code> from the Active Variable list, click or type <code>*</code> , and select <code>density</code> from the Active Variable list.
<code>SQRT(pressure[73]*2.5) + velocity[X][73]</code>	Square root of (pressure at node 73 * 2.5 + the X component of velocity at node 73) To build, select <code>SQRT</code> from the Math function list, select <code>pressure</code> from the Active Variable list, click or type <code>[73]*2.5)+</code> , select <code>velocity</code> from the Active Variable list, and click or type <code>[X][73]</code> .
<code>pressure{19}</code>	Scalar variable equal to <code>pressure</code> at time 19. This variable <i>will not</i> change if the current time step is changed. To build, select <code>pressure</code> from the Active Variable list and click or type <code>{19}</code> .
<code>MAX(plist, pressure)</code>	Constant variable equal to the maximum value for <code>pressure</code> over all nodes of all parts in <code>plist</code> . To build, select <code>MAX</code> from the General function list and follow the instructions in the Feedback area.
<code>(pressure/max_pres)^2</code>	Scalar variable equal to squared normalized <code>pressure</code> . To build, first calculate the <code>MAX</code> constant variable as described in the preceding example (here named <code>max_pres</code>). Click or type <code>(</code> , select <code>pressure</code> from the Active Variable list, click or type <code>/</code> , select <code>max_pres</code> from the Active Variable list, and click or type <code>)^2</code> .

Since EnSight can compute only one variable at a time, one must break down involved equations into multiple smaller ones, using temporary or intermediate variables.

Calculator limitations include the following:

1. The variable name cannot be used in the expression. The following is invalid:

```
temperature = temperature + 100
```

Instead use:

```
temperature2 = temperature + 100
```

2. The result of a function cannot be used in an expression.

```
(pressure / MAX(plist,pressure) )^2
```

Instead use two steps. Define `p_max` as:

```
MAX(plist,pressure)
```

then define `norm_press_sqr` as:

```
(pressure / p_max)^2
```

3. Created parts (or changing geometry model parts) cannot be used with a time calculation (using `{ }`).
4. Calculations occur only on server-based parts. Client-based parts are ignored, and variable values may be undefined.



Built-in Function Reference

Although all built-in functions are listed here, consult the [User Manual](#) for the complete definition of a function. EnSight provides the following built-in general variable calculation functions:

Function		Abbreviation (if any)	Description
Area			Surface area
Boundary Layer	Cf at Wall	BL_CfWall	Boundary Layer Cf at the wall
	Displacement Thickness	BL_DispThick	Boundary Layer displacement thickness
	Distance to Value from Wall	BL_DistToValue	Boundary Layer distance to value from the wall
	Momentum Thickness	BL_MomeThick	Boundary Layer momentum thickness
	Thickness	BL_Thick	Boundary Layer thickness
	Y1 off Wall	BL_Y1Plus	Boundary Layer Y1 off wall
Case Map		CaseMap	Map values of a variable from one case onto the nodes of another case.
Coefficient		Coeff	Coefficient
Complex		Cmplx	Create complex variable from variables representing the real and imaginary portions.
	Argument	CmplxArg	Argument of complex variable
	Conjugate	CmplxConj	Conjugate of complex variable
	Imaginary	CmplxImag	Imaginary portion of complex variable
	Modulus	CmplxModu	Modulus of complex variable
	Real	CmplxReal	Real portion of complex variable
	Transient Response	CmplxTransResp	Complex transient response
Curl			Curl of a vector
Density			Density
Distance Between 2 Nodes		Dist2Nodes	Distance between two nodes
Divergence		Div	Divergence
Dynamic Pressure		PresDynam	
Element to Node		ElemToNode	Make node-based variable from element-based variable (via average)
Energy, Total		EnergyT	Total Energy
Enthalpy			
Entropy			
Flow			Integrated flow through 1D/2D part
	Rate	FlowRate	
Fluid Shear Stress		FluidShear	Fluid shear stress
	Max	FluidShearMax	Max of fluid shear stress
Force			Force Vector
	on 1D part	Force1D	Force Vector on 1D part
Gradient		Grad	3D gradient of a variable
	Approximation	GradApprox	Linear, closed-form gradient approximation
	Tensor	GradTensor	3D tensor gradient
	Tensor Approximation	GradTensorApprox	Linear, closed-form tensor gradient approximation
Helicity	Density	HelicityDensity	
	Relative	HelicityRelative	
	Relative Filtered	HelicityRelFilter	
Iblanking Values		IblankingValues	Scalar that is the iblanking flag per node
Kinetic Energy		KinEn	Kinetic energy
Length			Summed length of all 1D elements
Line Integral		IntegralLine	Integral over 1D elements
Log of Normalized	Density	DensityLogNorm	
	Pressure	PresLogNorm	
	Temperature	TemperLogNorm	
Mach Number			Mach number
Make Scalar at Elements		MakeScalElem	Scalar created, by placing a constant value at each element



Function		Abbreviation (if any)	Description
Make Scalar at Nodes		MakeScalNode	Scalar created, by placing a constant value at each node
Make Vector		MakeVect	Build a vector variable from scalars
Massed Particle Scalar		MassedParticle	Massed particle scalar
Mass Flux Average		MassFluxAvg	
Maximum		Max	Find spatial max of variable over part(s) at current time
Minimum		Min	Find spatial min of variable over part(s) at current time
Moment			Moment component of a force component based on the current position of the Cursor Tool. This is a constant.
Moment Vector		MomentVector	Moment component of a force component at each node of selected parts. This is a field of vectors.
Momentum		Momentum	
Node To Element		NodeToElem	Make an element-based variable from node-based (via average)
Normal			Surface normal vector
Normal Constraints		NormC	NC
Normalized	Density	DensityNorm	
	Enthalpy	EnthalpyNorm	
	Pressure	PresNorm	
	Stagnation Density	DensityNormStag	
	Stagnation Enthalpy	EnthalpyNormStag	
	Stagnation Pressure	PresNormStag	
	Stagnation Temperature	TemperNormStag	
	Temperature	TemperNorm	
	Vector	NormalizeVector	Vector field expressed as unit vectors.
Offset	Field	OffsetField	Offset distance field (from boundary)
	Variable	OffsetVar	Variable Value offset from boundary of part into the field (placed on boundary)
Pitot	Pressure	PresPito	
	Pressure Ratio	PresPitoRatio	
Pressure		Pres	Pressure
	Coefficient	PresCoef	
Rectangular To Cylindrical Vector		RectToCyl	Calculate vector in cylindrical coordinates
Shock Plot3d		ShockPlot3d	
Sonic Speed		SonicSpeed	
Spatial Mean		SpaMean	Mean of a variable over a part
Speed			Magnitude of velocity
Stagnation	Density	DensityStag	
	Enthalpy	EnthalpyStag	
	Pressure	PresStag	
	Pressure Coefficient	PresStagCoef	
	Temperature	TemperStag	
Stream Function		Stream	Stream
Surface Integral		IntegralSurface	Integral over 2D elements
Swirl		Swirl	
Temperature			Temperature
Temporal Mean		TempMean	Mean of a variable over time



Function		Abbreviation (if any)	Description
Tensor	Component	TensorComponent	Component of a tensor variable
	Determinant	TensorDeterminant	Determinant of a tensor variable
	Eigenvalue	TensorEigenvalue	Eigenvalue of a tensor
	Eigenvector	TensorEigenvector	Eigenvector of a tensor
	Make	TensorMake	Make symmetric tensor from variables representing components
	Make Asymmetric	TensorMakeAsym	Make asymmetric tensor from variables representing components
	Tresca	TensorTresca	Tresca failure theory of a tensor
	Von Mises	TensorVonMises	Von Mises failure theory of a tensor
Total Pressure		PressT	Total pressure
Velocity		Velo	Momentum/density
Volume		Vol	Volume of 3D elements
Volume Integral		IntegralVolume	Integral over 3D elements
Vorticity		Vort	Vorticity

The following standard math functions are also available:

Function	Abbreviation
Absolute Value	ABS
Arccosine	ACOS
Arcsine	ASIN
Arctangent	ATAN
Arctangent (y / x)	ATAN2
Cosine	COS
Cross Product	CROSS
Dot Product	DOT
Exponent	EXP

Function	Abbreviation
Greater Than	GT
Less Than	LT
Log Natural	LOG
Log Base 10	LOG10
Root Mean Squared	RMS
Round	RND
Sine	SIN
Square Root	SQRT
Tangent	TAN

For information on the arguments (and equations), see [General Functions](#) or [Math Functions](#) in the User Manual.



Extended CFD Variables

Rather than having to individually create the various common CFD variables, EnSight can automatically make them available for use if the appropriate basis variables and constants have been provided. This can be accomplished after loading the model with the Extended CFD Variable Settings Dialog:

1. From either the Variable or the Calculator Feature Detail Editor, click the Extended CFD Variables... button.



2. Select the variable name in the list and then click the appropriate SET button.

For example, select Density in the list and then click the SET button to right of the Density field.

3. After all variables and constants have been specified, click Show Extended CFD Variables.

4. Click Okay.

The common CFD variables will now be listed in the main variables list. Note that they will NOT actually be computed until activated.

If you have a "standard" PLOT3D Q file, the above process can be accomplished automatically by starting EnSight with the "-cfd" option on the command line.

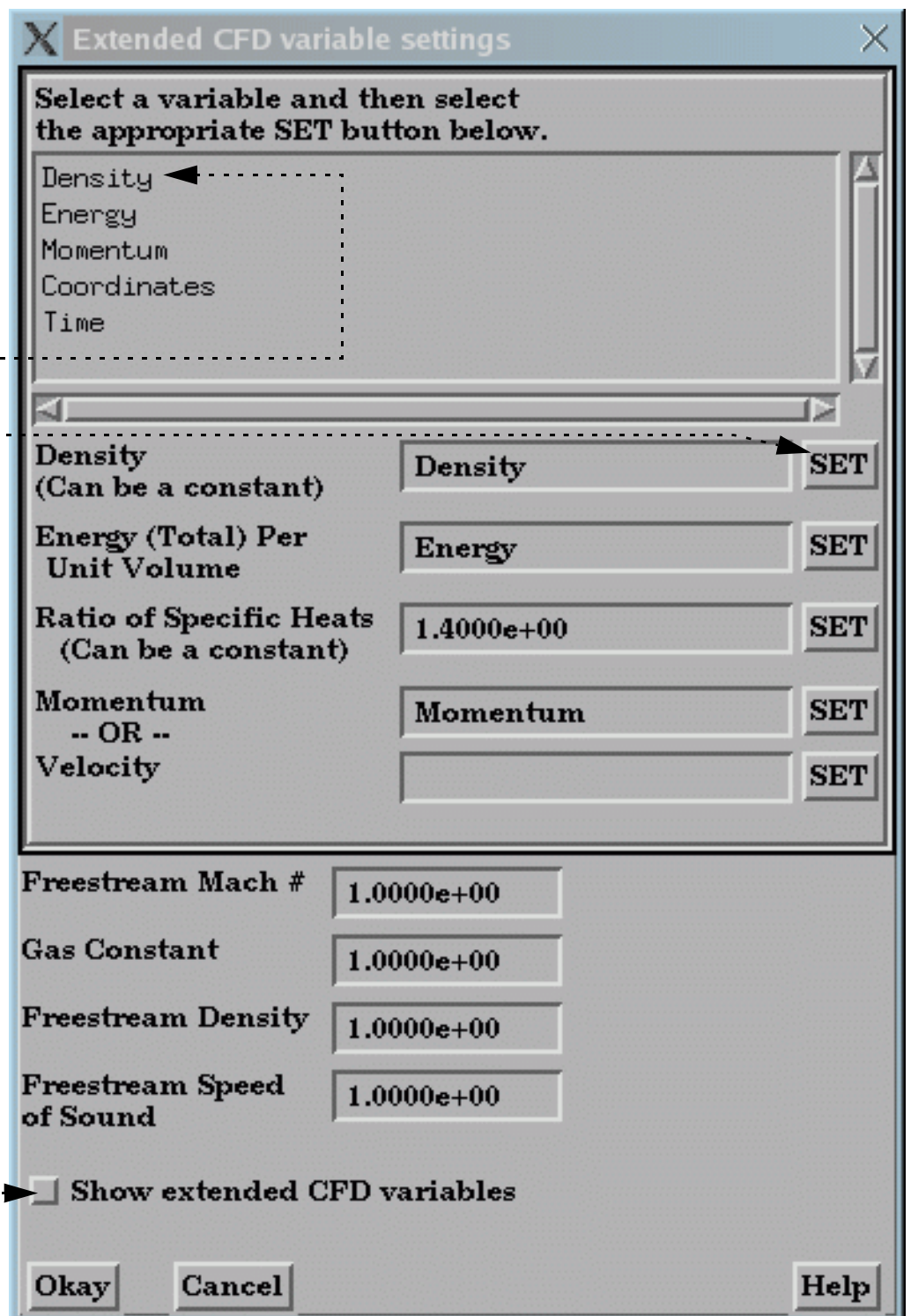

SEE ALSO

[How to Edit Color Maps](#)

User Manual: [Variable Creation](#)



INTRODUCTION

EnSight can compute the following boundary layer parameters:

boundary layer thickness	named:	(bl_thickness)
displacement thickness		(bl_displ_thickness)
momentum thickness		(bl_momen_thickness)
shape parameter		(bl_shape_parameter)
skin friction coefficient		(bl_skin_friction)

You must have a 2D surface in a 3D field and specify the 2D surface as the parent part(s).

For a complete description of these variables, refer to the User Manual section below.

BASIC OPERATION

1. Select the 2D parent part(s).
2. Click the Boundary Layer variable icon.

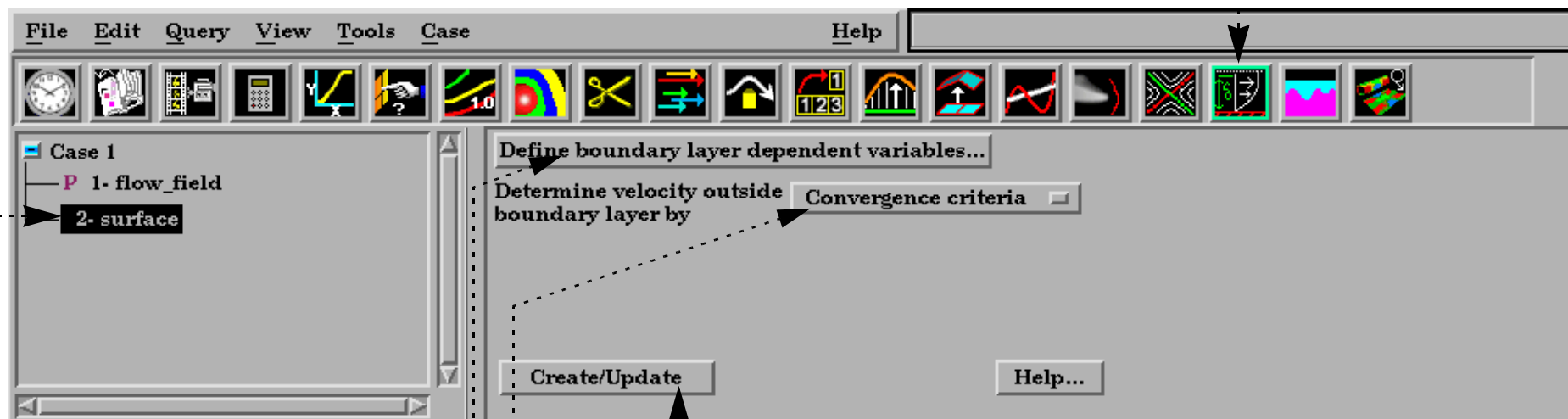

3. Bring up the dialog defining the necessary variables by clicking here.

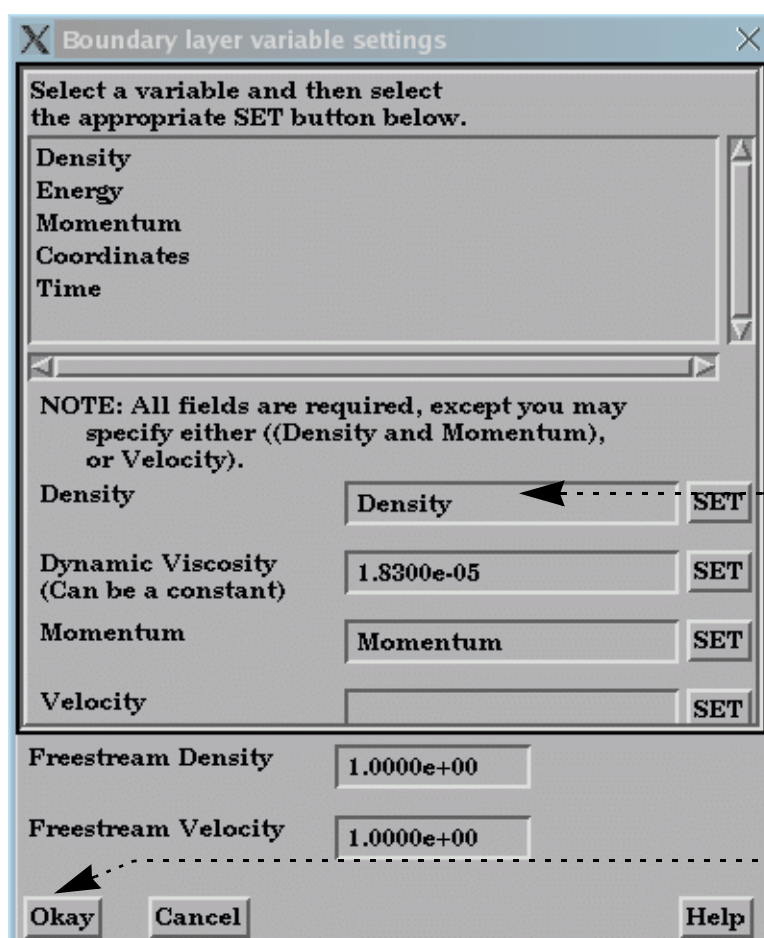

4. Define either (Density and Momentum) or velocity.

The variables can be set by either typing them into the fields, or selecting them from the list and clicking on the Set button.

6. Choose the method that will be used to determine the velocity outside the boundary layer.

7. Click Create/Update.

This will create the five new variables, which can be used for further operations - such as part coloring.

5. Click Okay to finish the variable setup.



OTHER NOTES

These variables and more are also individually available in the Variable calculator. See the [Boundary Layer Variables](#) section of Chapter 4 in the User Manual

Boundary Layer variables do not work with multiple cases.

SEE ALSO

[How To Create New Variables](#)

User Manual: [Boundary Layer Variables Create/Update](#)



Edit Color Palettes

INTRODUCTION

All scalar and vector variables have an associated color palette that defines the mapping from variable values to colors. These palettes can be easily edited to customize the mapping. Color palettes can also be saved to disk and restored during a subsequent session.

BASIC OPERATION

Color Palettes have five basic components:

- Levels** A palette can have up to 21 Levels at which the variable value is specified. Note that the number of Levels also controls the number of contour loops created for **contour parts** that depend on the variable.
- Scale** The palette scale controls how variable values are assigned to Levels between the minimum and maximum. Choices are linear (the default), quadratic (x^2), or logarithmic (\log_{10}).
- Type** The palette type controls how color is interpolated across part elements and from Level to Level:
 - Continuous:* Color is linearly interpolated across elements.
 - Banded:* Geometry is colored in discrete bands of uniform color where the band boundaries are permitted to cross element faces (as controlled by the nodal variable values).
 - Constant:* Each element is colored by the color of the first node of the element.
- Limit Fringes** Limit Fringes controls how color is set for nodes outside the range of variable values specified by the palette:
 - No:* Nodes above the range are colored by the maximum color; those below by the minimum color.
 - By Model Color:* Nodes outside the range are colored by the underlying part color.
 - By Invisible:* Elements whose nodes are outside the range are not displayed at all.
- Display Undefined** Controls how coloring is set when the variable value for nodes / elements are undefined:
 - By Part Color:* Color the element by the part color.
 - By Invisible:* Do not display the element.

The default color palette created for each variable has five Levels (with the minimum and maximum set to the range of the variable at the time step selected when the variable was activated), a linear scale, and is of type Continuous. The color ramp is a standard spectrum with the five Levels set to (from min to max) blue, cyan, green, yellow, and red.

EnSight can display multiple color legends in the Graphics Window:

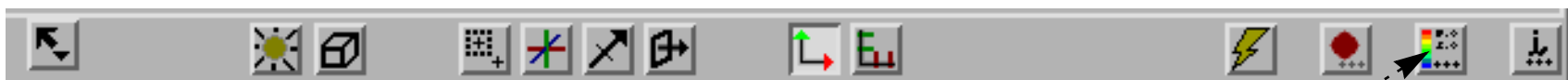

1. Click the Legend... button on the desktop.....

2. Select the desired variable(s) in the list.

For vector variables, you can select magnitude (or click Show Components to be able to select the components as well).

To remove a legend:

Repeat 1. and 2. above

or

You can remove all legends by clicking the All Off button.

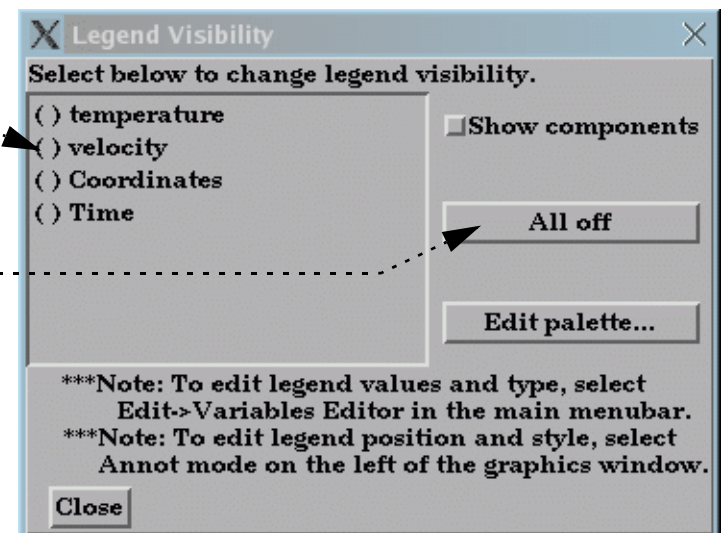

Color legends have a number of display attributes including size, position, and how/where the variable labels are formatted. See [How To Create Color Legends](#) for details.



The **Feature Detail Editor for Variables** provides access to all aspects of variables. The following shows the components of the dialog in Advanced Interface mode:

1. Double-click the Color icon in the Part Mode bar to open the Feature Detail Editor for Variables.



Use the File menu to save and restore palettes.

Available variable	Type	Result
temperature	(*) Gvn(N)	Scalar
velocity	() Gvn(N)	Vector
Coordinates	(*) Gvn(N)	Vector
Time	(*) Gvn(N)	Scalar

Available variable list. A * indicates that the variable is currently active. Selected variable is highlighted.

Variable type (constant, scalar, vector).

Whether given (Gvn) or computed (Cmp).

Buttons to activate and deactivate selected variables.

Histogram of the distribution of the selected variable. Provides control for:

Minimum Palette Value Slider.
Histogram Scale Adjustment

Overall min/max for the selected variable

Calculate overall min/max from Beg to End time steps (and update histogram)

Color palette – click on a label to set the current Edit Level

Swap the colors from top to bottom

Select component of vector variables

Maximum Palette Value Slider

Palette type (Continuous, Banded, Constant)

Palette scale (Linear, Quadratic, Logarithmic)

Limit Fringes toggle

Display Undefined Regions (By Part Color or Invisible)

Number of Levels in the palette

Current Edit Level

Automatic Level interpolation toggle

Variable value assigned to current Edit Level

RGB color assigned to current Edit Level



Changing Color Palettes - Basic Operation:

1. Double-click the Color icon in the Part Mode bar to open the Feature Detail Editor for Variables (or double-click the desired variable in the Part color, lighting, & transparency dialog).....



By default, the changes you make to a color palette have an immediate effect. For large models, the response rate for interactive editing (e.g. changing the minimum by moving the Minimum Palette Value slider in the histogram) can be too slow. To disable this behavior, select Edit > Immediate Modification (in the Feature Detail Editor) to toggle this setting off. To apply your changes, click the Apply Changes button at the bottom of the dialog.

2. Select the desired variable. Click Activate if it has not been activated.

Available variable	Type	Result
temperature	(*) Gvn(N) Scalar	
velocity	() Gvn(N) Vector	
Coordinates	(*) Gvn(N) Vector	
Time	(*) Gvn(N) Scalar	

3. Select Simple Interface

To change the minimum or maximum:

4. Grab the Minimum (or Maximum) Palette Value slider (the white vertical bars) and adjust to the desired location.

or:

5. Enter new Minimum (or Maximum).

or

6. Select the desired parts and click this button to get min/max values based on these parts.

7. Enter new number of levels(2 to 21)

To change the number of levels:

8. Select a new palette and click Restore

To change the colors associated with the values:

9. Select the palette and click Undo Restore

Apply changes



ADVANCED USAGE

1. Double-click the Color icon in the Part mode bar to open the Feature Detail Editor for Variables (or double-click the desired variable Part color, lighting, & transparency dialog):



By default, the changes you make to a color palette have an immediate effect. For large models, the response rate for interactive editing (e.g. changing the minimum by moving the Minimum Palette Value slider in the histogram) can be too slow. To disable this behavior, select Edit > Immediate Modification (in the Feature Detail Editor) to toggle this setting off. To apply your changes, click the Apply Changes button at the bottom of the dialog.

2. Select Advanced Interface

There are several ways to edit a color map.

3. Select the desired variable. Click Activate if it has not been activated.

To change the minimum or maximum (and have the intermediate Levels adjust accordingly):

4. Grab the Minimum (or Maximum) Palette Value slider (the white vertical bars) and adjust to the desired location.

To change the number of Levels:

4. Enter the desired value (between 2 and 21) in the # of Levels field and press return.

Note that this will also change the number of contour loops for any current contour parts that depend on the selected variable.

To edit individual Levels:

4. Select the desired Level: either click on the Level label, OR enter the Level number into the Edit Level field and press return.

5. If you wish to automatically interpolate the variable values at preceding (lower) Levels, toggle on Interpolate to Level and enter the desired Level to interpolate to.

6. To change the variable value associated with the Level, enter the new value in the Value field and press return.

7. To change the color associated with the Level, enter the new color in the RGB fields OR click Mix... to open a Color Selector.

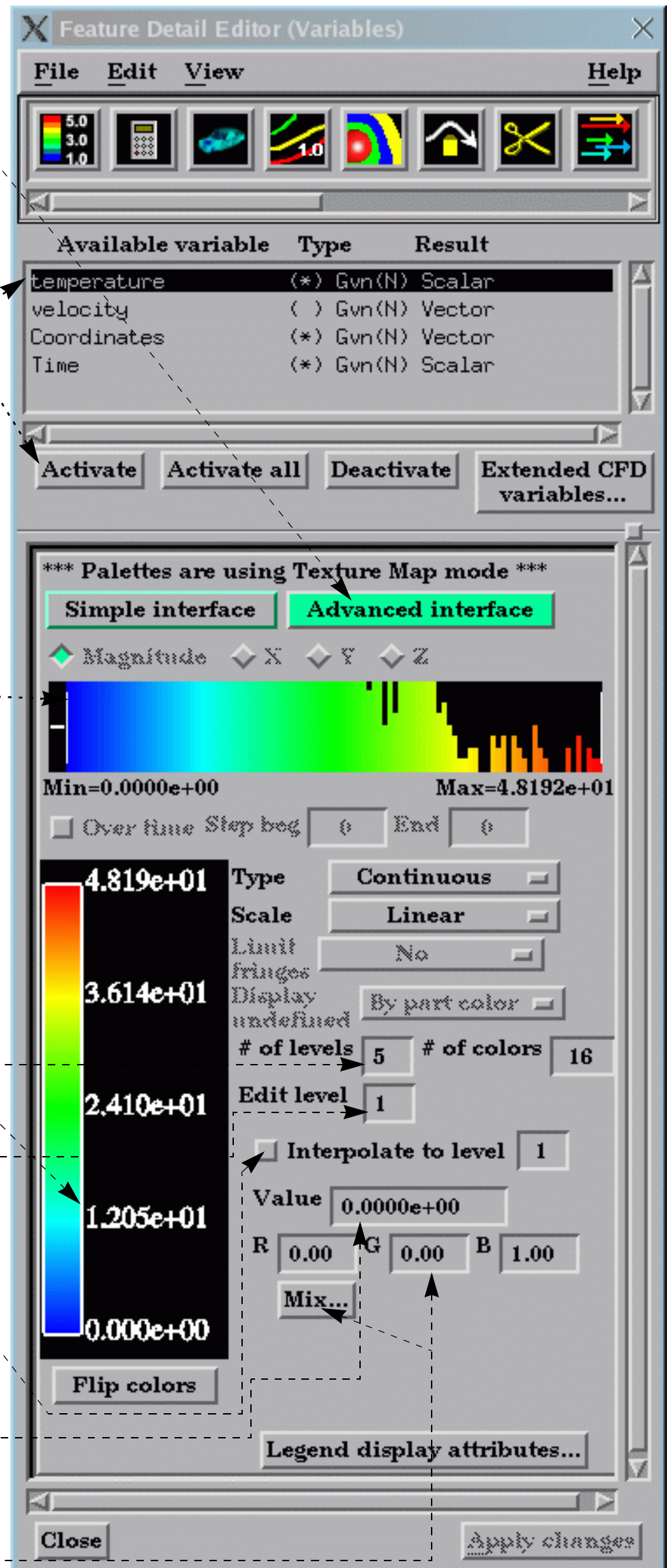



OTHER NOTES

When a variable is first activated, the minimum/maximum settings for the associated palette are set to the minimum/maximum values of the variable. Although this is the standard way of initializing color maps, it can result in under utilization of the palette since typically only one node has the minimum or maximum value. You can override this default behavior by using the option “-range10” when you start EnSight. This will shrink the palette towards the median value by 10% off the top and the bottom. In previous releases of EnSight this was the default behavior.

SEE ALSO

[How To Create Color Legends](#), [How To Create New Variables](#), [How To Create Contours](#)

User Manual: [Variable Summary & Palette](#) and [Palette File Formats](#)





INTRODUCTION

EnSight provides many methods for extracting exact quantitative data from your results. Specific information about nodes, elements, parts, IJK locations, or arbitrary points can be displayed.

BASIC OPERATION

Show Point Information

To show information about an arbitrary point:

1. If your data is transient, set the desired time using the Solution Time Quick Interaction area (Edit > Solution Time Editor...).
2. If you have multiple **Cases**, select the desired case using Case > *casename*.
3. Position the **Cursor Tool** to the desired location.
4. Select the desired part(s) in the Main Parts List. The query will only be successful if the Cursor Tool is found within an element of a selected part.
5. Select Query > Show Information > Cursor.

The query results will be printed to the EnSight message window, which will pop up.

It can also be accessed from the Info icon: 

The following shows sample output from a point query:

```
Point (6.19810e-01,2.77589e-01,2.41451e-01)(In Frame 0) Query Information.
Found in structured part # 2.
Found in element # 168379.
Closest node # 1782 (within the element)
Value for Variable density is 9.96230e-01.
Values for Variable momentum are:
x=3.03989e-01,y=-1.42727e-02,z=8.51241e-02,mag=3.16005e-01.
```

Show Node Information

To show information about a specific node, you must have either given or automatically assigned node labels for your data. You must also know the number of the node of interest. If you do not know the number, you can display **node labels** for the part or, if you know an element that contains the node, you can display element information for the element (as described in the next section). To show node information:

1. If your data is transient, set the desired time using the Solution Time Quick Interaction area (Edit > Solution Time Editor...).
2. If you have multiple **Cases**, select the desired case using Case > *casename*.
3. Select the desired part(s) in the Main Parts List. The query will only be successful if the specified node is found in a selected part.
4. Select the variable(s) you wish to query in the Main Variables List (only node-based variables will be queried).
5. Select Query > Show Information > Node. The Query Prompt dialog opens. Enter the ID number of the desired node in the text field and click Okay.

The query results will be printed to the EnSight message window, which will pop up.

It can also be accessed from the Info icon: 

The following shows sample output from a node query:

```
Node 123 Query Information.
Coordinates (In Frame 0) are: (-2.00000e+00,0.00000e+00,1.19320e+00)
Found in unstructured part # 1.
Values for Variable velocity are:
x=5.82290e-01,y=3.70160e-02,z=-1.82780e-03,mag=5.83468e-01.
```



Show IJK Information

To show information about a specific IJK location for structured models:

1. If your data is transient, set the desired time using the Solution Time Quick Interaction area (Edit > Solution Time Editor...).
2. If you have multiple **Cases**, select the desired case using Case > *casename*.
3. Select the desired part (one only) in the Main Parts List. The query will only be successful if the specified IJK is found in the selected part.
4. Select the variable(s) you wish to query in the Main Variables List (only node-based variables will be queried).
5. Select Query > Show Information > IJK. The Query Prompt dialog opens. Enter the values for the desired IJK location in the text fields and click Okay.

The query results will be printed to the EnSight message window, which will pop up.

It can also be accessed from the Info icon.....



The following shows sample output from an IJK query:

```
IJK 2 5 10 Query Information.
Node Id is: 26146
Found in iblanked structured part # 1.
Coordinates (In Frame 0) are: (4.72982e-01,1.64710e-01,6.50679e-02)
No variables active to show values at the IJK location.
```

Show Element Information

To show information about a specific element, you must have either given or automatically assigned element labels for your data. You must also know the number of the element of interest. If you do not know the number, you can display **element labels** for the part. To show element information:

1. If your data is transient, set the desired time using the Solution Time Quick Interaction area (Edit > Solution Time Editor...).
2. If you have multiple **Cases**, select the desired case using Case > *casename*.
3. Select the desired part(s) in the Main Parts List. The query will only be successful if the specified element is found in a selected part.
4. Select the variable(s) you wish to query in the Main Variables List (only element-based variables will be queried).
5. Select Query > Show Information > Element. The Query Prompt dialog opens. Enter the ID number of the desired element in the text field and click Okay.

The query results will be printed to the EnSight message window, which will pop up.

It can also be accessed from the Info icon.....



The following shows sample output from an element query:

```
Element 321 Query Information.
Found in unstructured part # 2.
Type of element is 6 Noded triangle
Number of nodes is 6
Node IDs are: 1050 910 1054 1052 1053 1055
Neighboring Element Information is:
Element neighbor 318 is of type 6 Noded triangle
Element neighbor 322 is of type 6 Noded triangle
```



Show Part Information

To show information about a part:

1. If your data is transient, set the desired time using the Solution Time Quick Interaction area (Edit > Solution Time Editor...).
2. Select the desired part in the Main Parts List.
3. Select Query > Show Information > Part.

The query results will be printed to the EnSight message window, which will pop up.

It can also be accessed from the Info icon.....

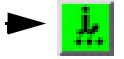

The following shows sample output from a part query:

```
Part 2 Query Information.  
Unstructured part.  
Number of nodes 2380  
Minimum coordinate(In Frame 0) is (0.00000e+00,0.00000e+00,0.00000e+00)  
Maximum coordinate(In Frame 0) is (3.80000e+01,1.20000e+01,0.00000e+00)  
Min node label in part is (1)  
Max node label in part is (2380)  
Element Information is:  
Element type: 6 Noded triangle, count = 1128.  
Min element label in part is (1)  
Max element label in part is (1128)
```

SEE ALSO

[How To Query/Plot](#), [How To Probe Interactively](#).

User Manual: [Show Information](#)



INTRODUCTION

EnSight provides an interactive query capability that displays variable data in the Graphics Window as you move the mouse pointer over geometry, as you move the cursor tool within the model, or at specified node, element, ijk or xyz locations. The probe can display the value directly under the mouse pointer (by interpolating the nodal values of the applicable element) or search for and display the value at the node closest to the mouse pointer.

BASIC OPERATION

To probe interactively:

1. Click the Probe Icon (or select Query > Interactive Probe...).



2. Set the Query pulldown to desired operation.

3. Select the desired variable to display.

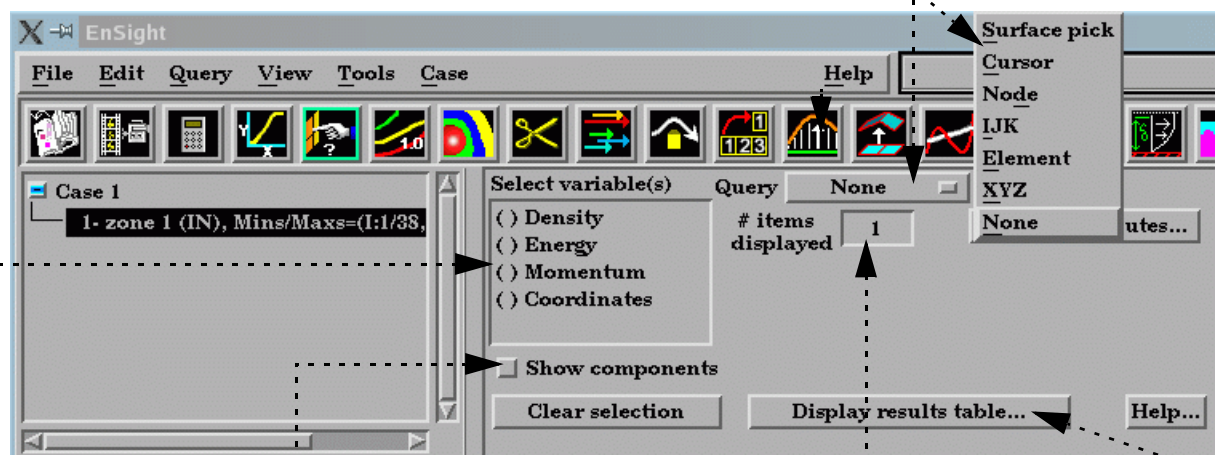

Surface Pick: Interpolate to any picked position on the surface of the model.

Cursor: Interpolate to location of cursor tool within the model.

Node: At a specific node number.

IJK: At a specific IJK location.

Element: At a specific element number.

XYZ: At a specific XYZ location.

4. If Query is set to Surface Pick, you can select:

- a) whether the probe will snap to closest node or
- b) use exact location.

And whether the information will be sampled:

- c) when you click the "p" keyboard key or
- d) continuously as you move the mouse.

If Query is set to Node, Element, IJK, or XYZ, enter ID or values needed followed by Enter.

If Query is set to Cursor, move the cursor tool to desired location and press the "p" keyboard key (while the mouse is in the graphics window).

5. Enter a value controlling the number of simultaneous probe markers displayed. Once this number has been reached, the oldest marker is replaced by each new marker.
6. If the selected variable is a vector variable, you can specify which component (or the magnitude) of the variable is displayed.
7. In addition to having the results displayed on the model in the graphics window, you can open a table that displays the results
8. When done, change the Query to None to disable interactive probing.

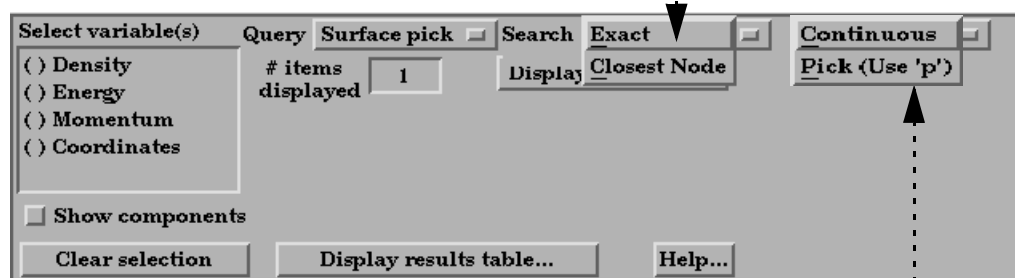



Probe Display Attributes

Probes are displayed as a marker (sphere) and the query text label. The appearance of the marker and label can be changed:

1. Click the **Display Attributes...** button in the **Probe Quick Interaction** area.

Toggle visibility for the query text label.

Set the color of the label.

Toggle visibility for the probe marker.

Set the color of the marker.

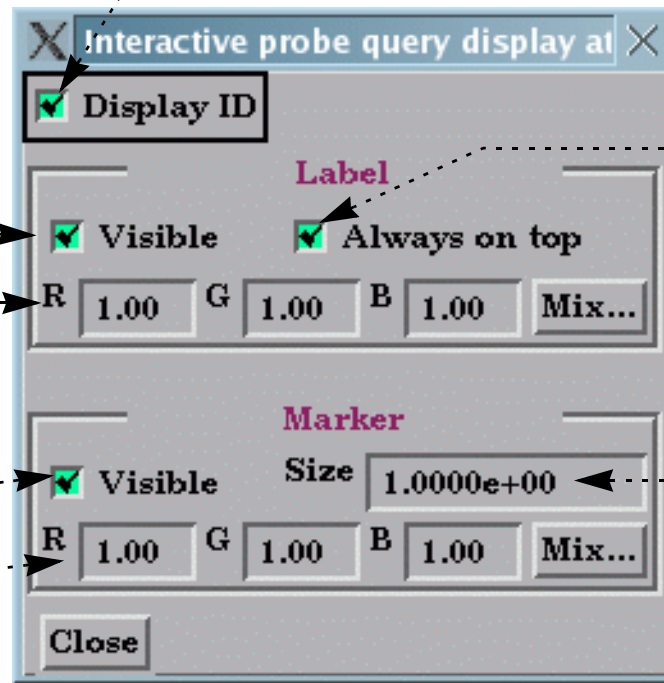

Toggle visibility for the id label. (Node id, element id, etc.)

Toggle whether query text labels are “always on top” (never hidden by geometry) or occluded by geometry that is closer.

Set the radius of all probe markers.

OTHER NOTES

Note that interactive query actions *do not* generate corresponding command language!

When in query mode with the Action set to Request, other picking options that use the ‘p’ key are disabled (such as the picks in Part Mode: Part, Cursor, Line, Plane, and LookAt Point).

The Quick Interaction area contains all the attributes that can be set for Probe Interactively. There is no Probe Feature Detail Editor.

SEE ALSO

[How To Query/Plot](#)

User Manual: [Interactive Probe Query](#)



Query/Plot

INTRODUCTION

EnSight can perform a number of different kinds of queries over time or space. The result is a Query Entity that can be plotted using EnSight's built-in [Plotting](#) facility or that can be printed as a table or written to a disk file.

BASIC OPERATION

One first must create query items, which can be any of the following types:

At Line Tool Over Distance. At 1D Part Over Distance.	At Node Over Time At Element Over Time At IJK Over Time At XYZ Over Time At Minimum Over Time At Maximum Over Time
By Operating on Existing Queries	
Read From An External File	

As one of these is selected, the Quick Interaction Area changes to reflect the information needed (such as variable to use) for the selected type. One can control whether the query entity will be a curve or a scatter plot by the choice for Variable 1 and 2.

Query entities can be printed to the Status History Area, saved to a file, deleted, or plotted.

Sample Query Creation and Plot (At Maximum Over time)

2. Click the Query/Plot icon (or select Query > Over Time/Distance...).

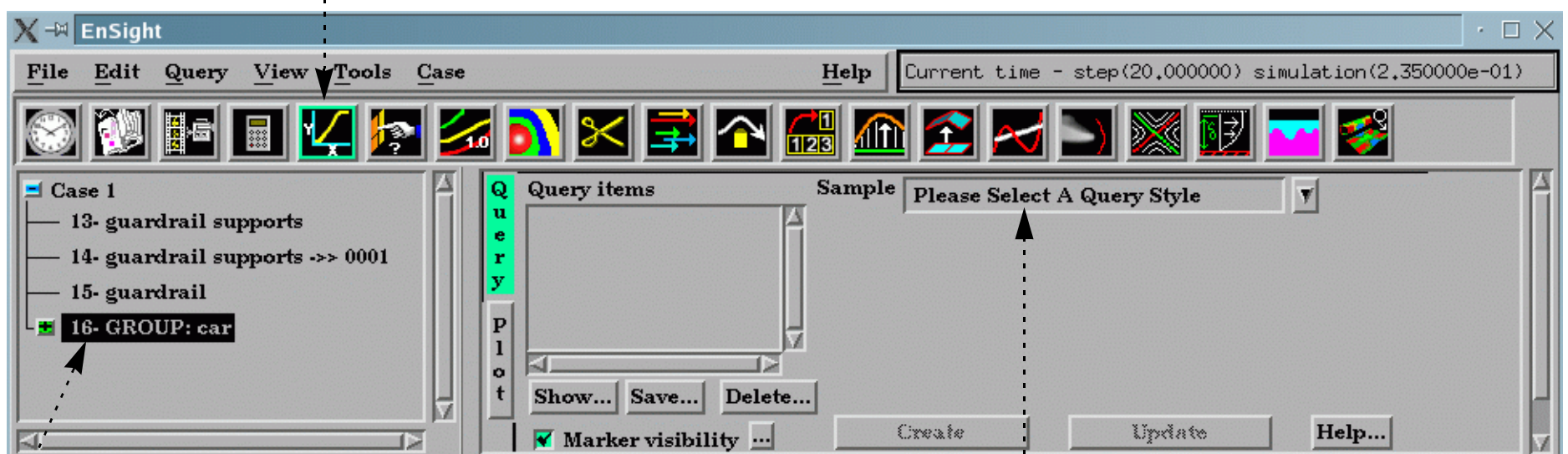

1. Select the part to query.

3. Select the Sample type for the query.

4. Select the variable for Variable: 1.

Leave Variable: 2 as None and it will default to Time, because of sample type.

5. Click Create

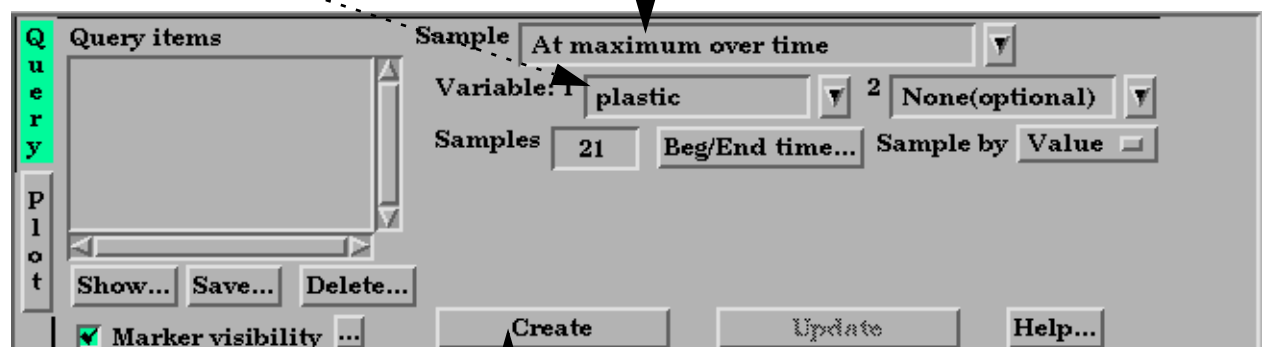



6. Click Plot

7. Select the Query Item to plot.

8. Click New Plotter.

Note: If any previous plotter has the correct type, it will show up in the list and can be selected instead of creating a new one, if desired.

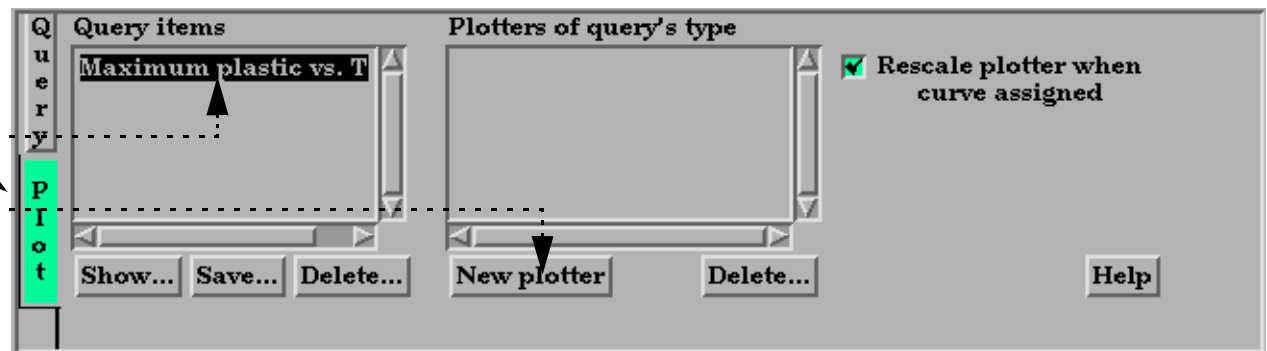

The plot will be displayed in the graphics window and will be listed in the Plotters Of Query's Type list. For more information on plotting, see the [Plotting](#) section towards the end of this How To.

Managing Query Entities

The Quick Interaction area provides various controls for managing existing Query Entities:

List of current Query Entities. Selected items are operated on by the following actions.

Plot the selected Query Entity as described above.

Append the text of the selected Query Entity to the Status History window.

Save the selected Query Entity to a disk file, either as xy data or in a formatted report-like manner.

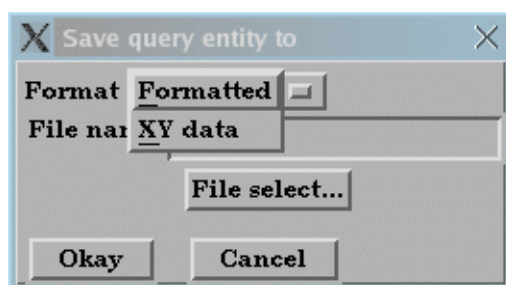

Note that previously created and saved query entities are restored through the use of the Read From An External File query Sample option.

Delete the selected Query Entity.

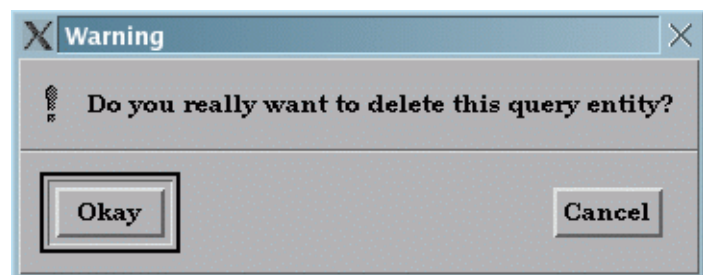

Update the selected query when any of its attributes or have been modified.

For various queries, marker visibility, as well as size and color can be controlled here as well.

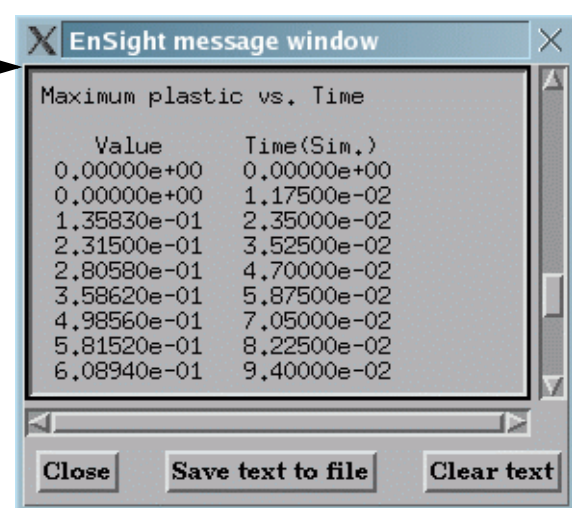
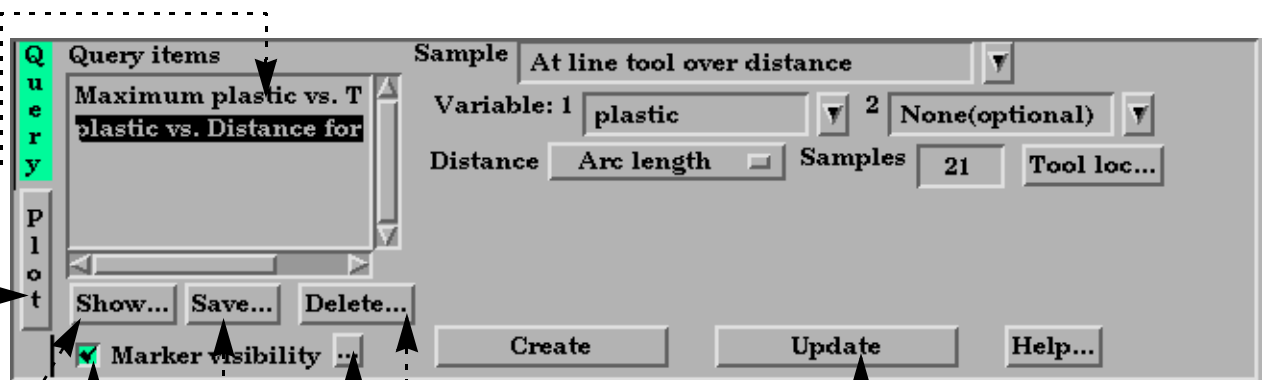
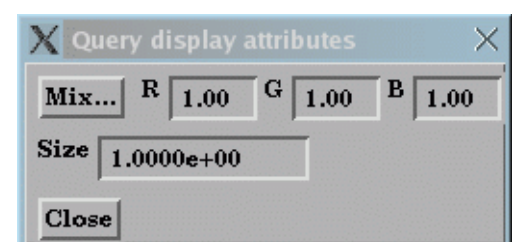



Over Distance Queries

EnSight can perform queries at uniform points along the line tool or at nodes along a 1D part. One-dimensional parts include model parts consisting of bar elements, 1D (Line) Clips, and particle traces.

At Line Tool Over Distance.

After selecting the part to query and clicking the Query/Plot icon

1. Select Sample as “At Line Tool Over Distance”

2. Select the variable to query over the distance in “Variable: 1”.

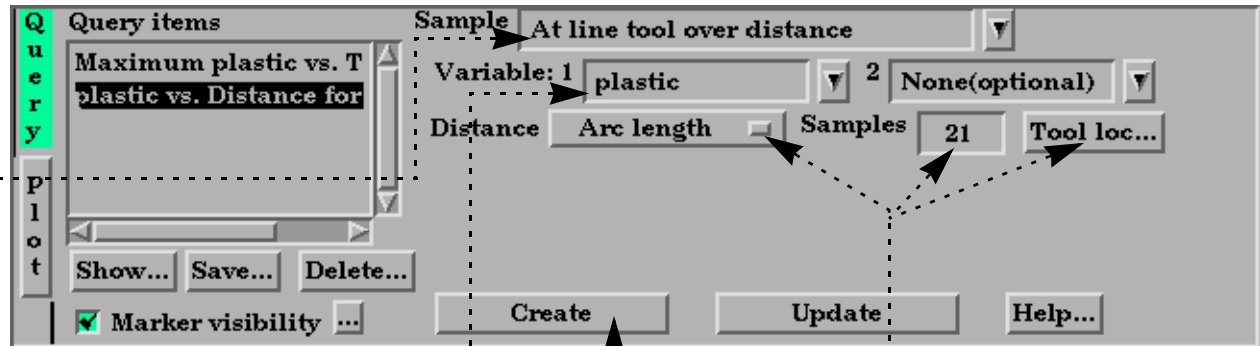

Leave “Variable: 2” as None unless you want a scatter query of two different variables along the line tool.

3. Optionally, select the Distance option desired, number of points along the line, and modify the tool location if needed.

4. Click Create

At 1D Part Over Distance.

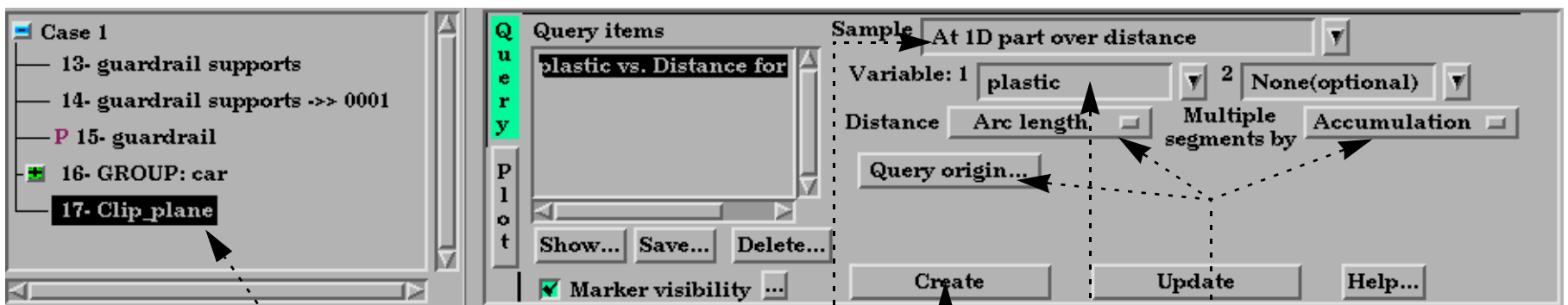

1. Select the part containing only 1D elements.

2. Select Sample as “At 1D Part Over Distance”.

3. Select the variable to query in “Variable: 1”.

4. Optionally modify Distance, origin and multiple segment attributes.

5. Click Create.

For the two over distance query types, the variable is plotted against the selected “Distance” metric. The node with the lowest node ID number is queried first. Since the nodes for 1D part over distance are not necessarily evenly spaced, the reported distance is one of the following:

Distance In Setting	Reported Distance
Arc Length	The distance along the part from the first node to each subsequent node (i.e. the sum of the 1D element lengths)
X Arc Length	The X coordinate value of each node accumulated from the start
Y Arc Length	The Y coordinate value of each node accumulated from the start
Z Arc Length	The Z coordinate value of each node accumulated from the start
From Origin	The distance from the origin
X From Origin	The X distance from the origin
Y From Origin	The Y distance from the origin
Z From Origin	The Z distance from the origin

If the 1D part contains more than one set of contiguous 1D elements (such as a particle trace from a Line emitter), the resulting query will contain one plot entity for each set.



Over Time Queries

For transient dataset, EnSight can query the variable values over a range of time at a particular node, element (or specific IJK coordinate for structured data) or an arbitrary point. You can also search the minimum or maximum of a variable over all nodes over a time range.

At Node Over Time

After selecting the part to query and clicking the Query/Plot icon

1. Select Sample as “At Node Over Time”

2. Select the variable to query over time in “Variable: 1”

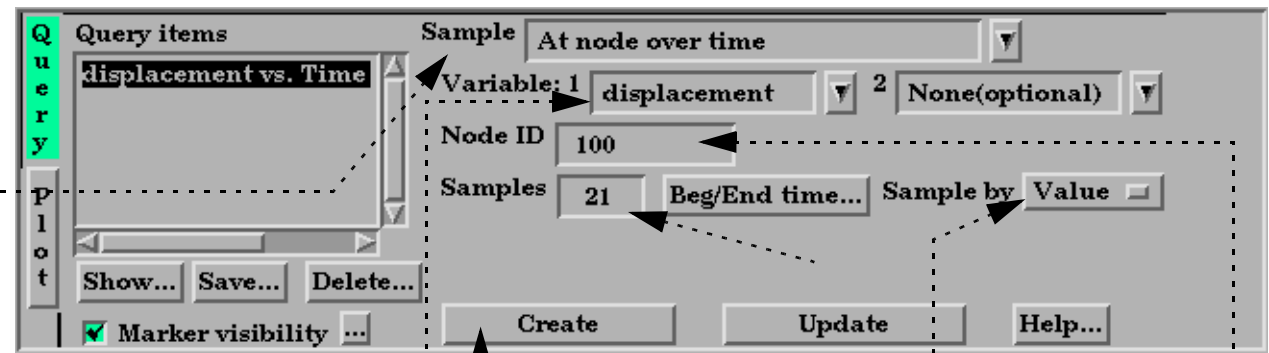

Leave “Variable: 2” as None unless you want a scatter query of two different variables over time.

3. Enter the Node ID.

4. Optionally, change the number of Samples (defaults to number of time steps), and whether to sample by Value of FFT.

5. Click Create

At Element Over Time

After selecting the part to query and clicking the Query/Plot icon

1. Select Sample as “At Element Over Time”

2. Select the variable to query over time in “Variable: 1”

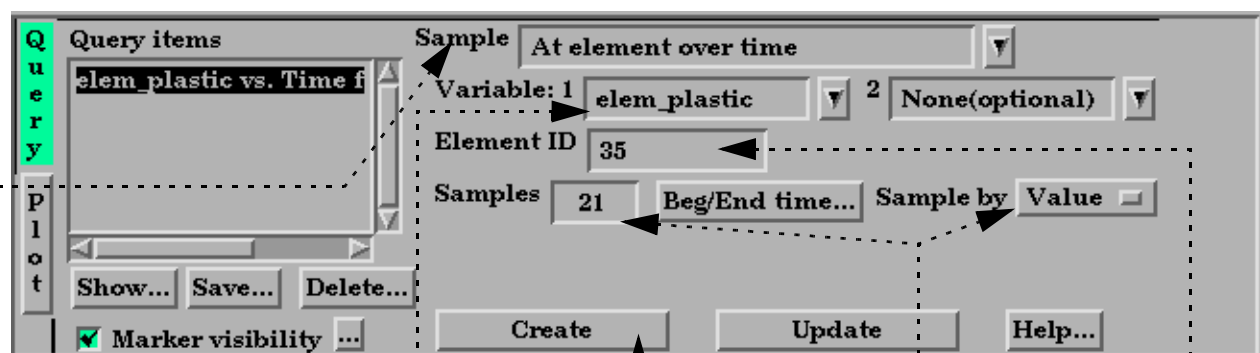

Leave “Variable: 2” as None unless you want a scatter query of two different variables over time.

3. Enter the Element ID.

4. Optionally, change the number of Samples (defaults to number of time steps), and whether to sample by Value of FFT.

5. Click Create

At IJK Over Time

After selecting the part to query and clicking the Query/Plot icon

1. Select Sample as “At IJK Over Time”

2. Select the variable to query in “Variable: 1”

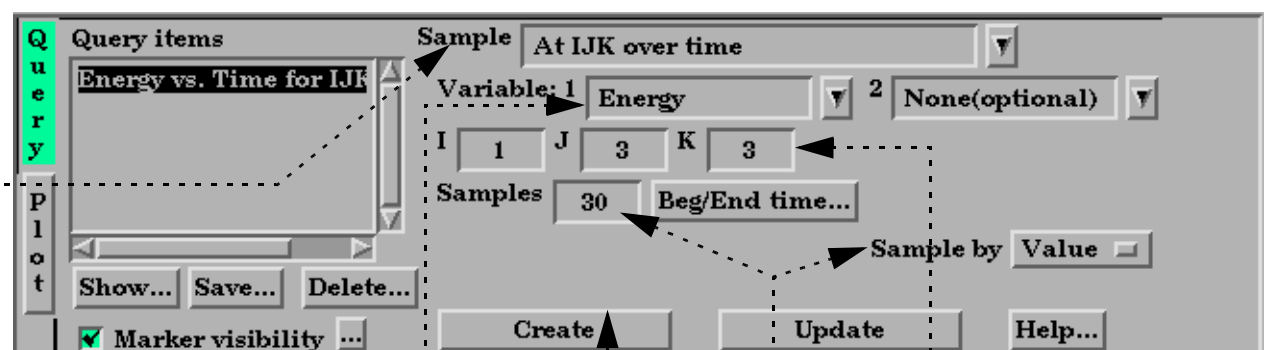

Leave “Variable: 2” as None unless you want a scatter query of two different variables over time.

3. Enter IJK for the point.

4. Optionally, change the number of Samples (defaults to number of time steps), and whether to sample by Value of FFT.

5. Click Create



At XYZ Over Time

After selecting the part to query and clicking the Query/Plot icon

1. Select Sample as “At XYZ Over Time”

2. Select the variable to query over time in “Variable: 1”.

Leave “Variable: 2” as None unless you want a scatter query of two different variables over time.

3. Either type in the desired xyz location or place the cursor where desired in the model, either through picking, or other transformation methods and click the cursor Get button.

4. Optionally, change the number of Samples (defaults to number of time steps), and whether to sample by Value of FFT.

5. Click Create

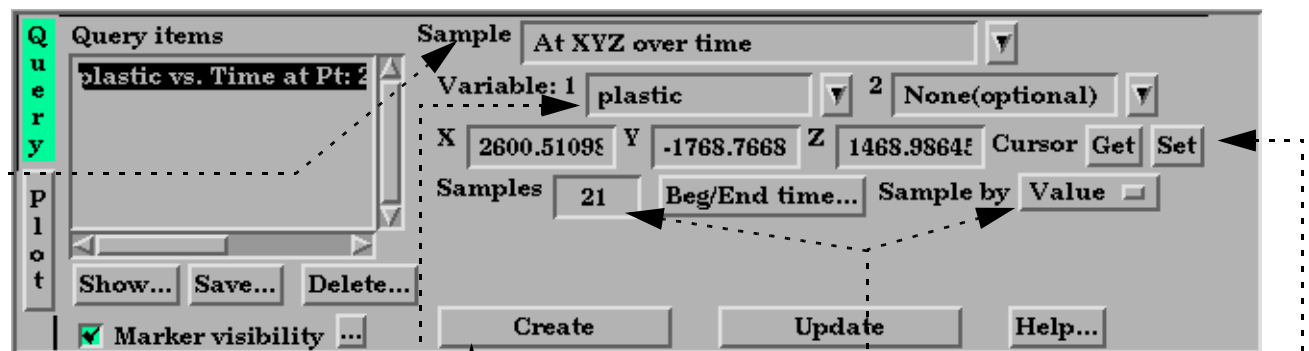

At Minimum Over Time

After selecting the part to query and clicking the Query/Plot icon

1. Select Sample as “At Minimum Over Time”

2. Select the variable to query over time in “Variable: 1”.

Leave “Variable: 2” as None unless you want a scatter query of two different variables over time.

3. Optionally, change the number of Samples (defaults to number of time steps), and whether to sample by Value of FFT.

4. Click Create

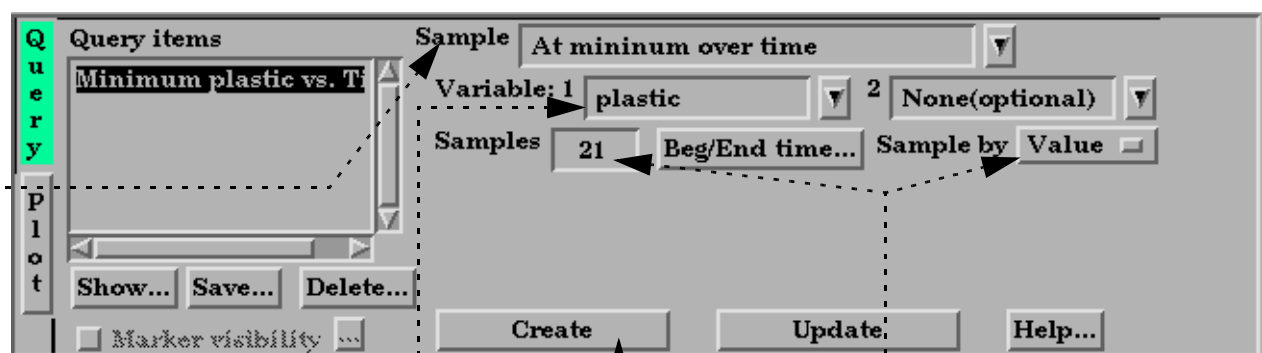

At Maximum Over Time

After selecting the part to query and clicking the Query/Plot icon

1. Select Sample as “At Maximum Over Time”

2. Select the variable to query over time in “Variable: 1”.

Leave “Variable: 2” as None unless you want a scatter query of two different variables over time.

3. Optionally, change the number of Samples (defaults to number of time steps), and whether to sample by Value of FFT.

4. Click Create

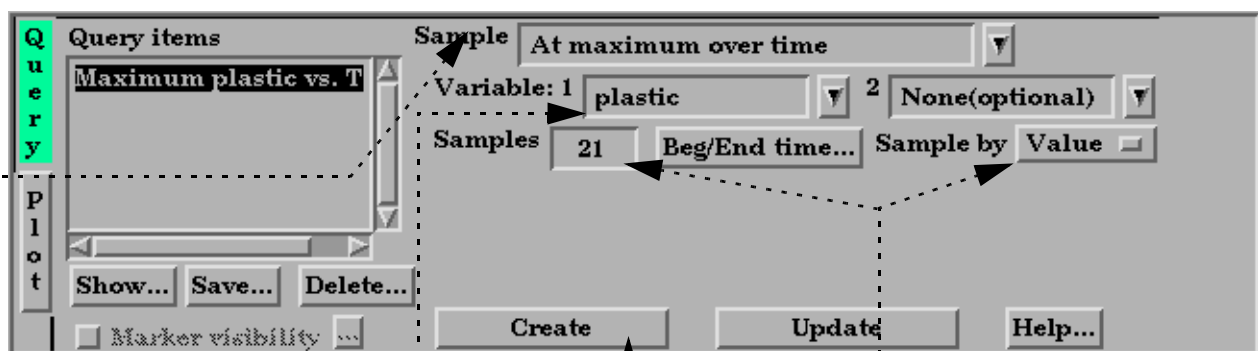



Scatter Query Example

Everything is done like a regular query except you select another variable in the Variable: 2 field, instead of leaving it as None.

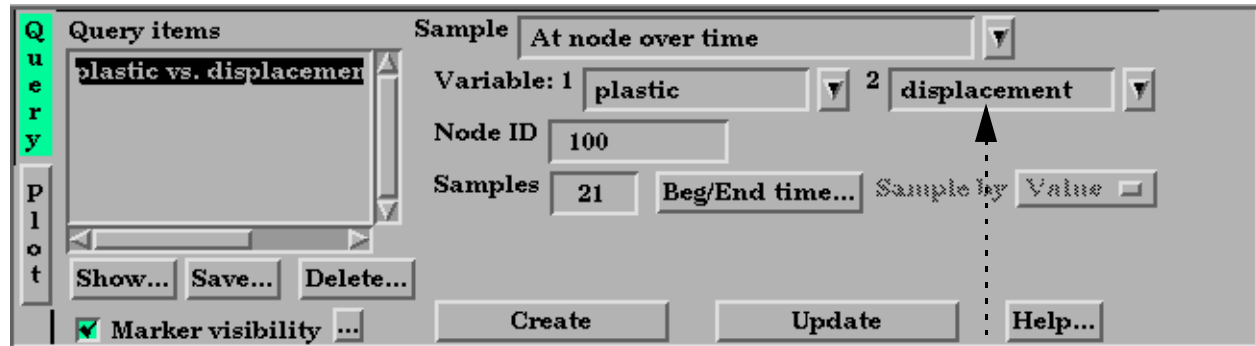

Operations on Existing Queries

You can perform a scaling of an existing query, or a scaling and algebraic addition of two queries, or an integration or differentiation of a query.

By Operating on Existing Queries

1. Select Sample as "By Operating On Existing Queries"

2. Select the operation.
(Combine/Scale, Integrate or Differentiate).

For Combine/Scale (shown):
3. Select the Query Item and set the Scale Factor if you want to scale a single query - or - Select both

Query Items and set both Scale Factors if you want to scale and add algebraically.

3. Click Create

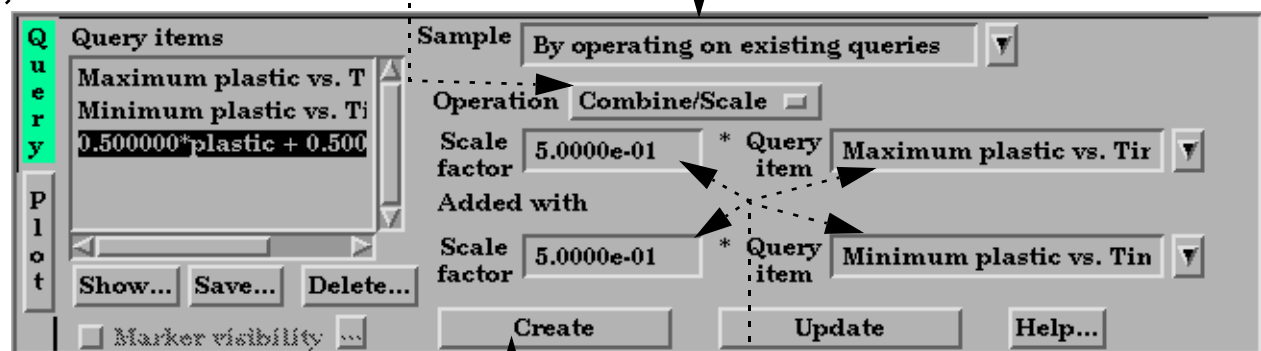

Note, if integrate or differentiate is chosen, you will only need to choose the query to operate on.

Queries From External Sources

You can import previously created and saved (or externally generated) EnSight queries or Dytran time history (.ths) files.

Read From An External File

1. Select Sample as "Read From An External File".

2. Click the "Load XY Data From File ..." button to open the File Selection dialog, and select any previously saved EnSight XY data file or a Dytran .ths file.

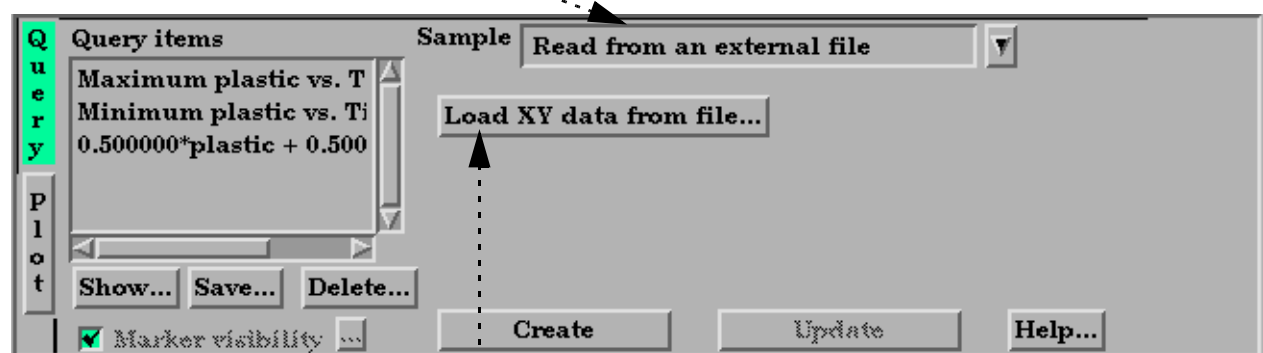



Plotting

Once Queries exist, they can be easily plotted in a new plotter in EnSight, or if an existing plotter of the correct type exists, they can be added to the existing plotter.

1. Select the Query Item to be plotted.

2. Click the New Plotter button if a new plotter is desired.

In this case we did not choose to plot the displacement vs. Time query on the already existing Maximum plastic vs. Time plot. Instead we created a new plotter.

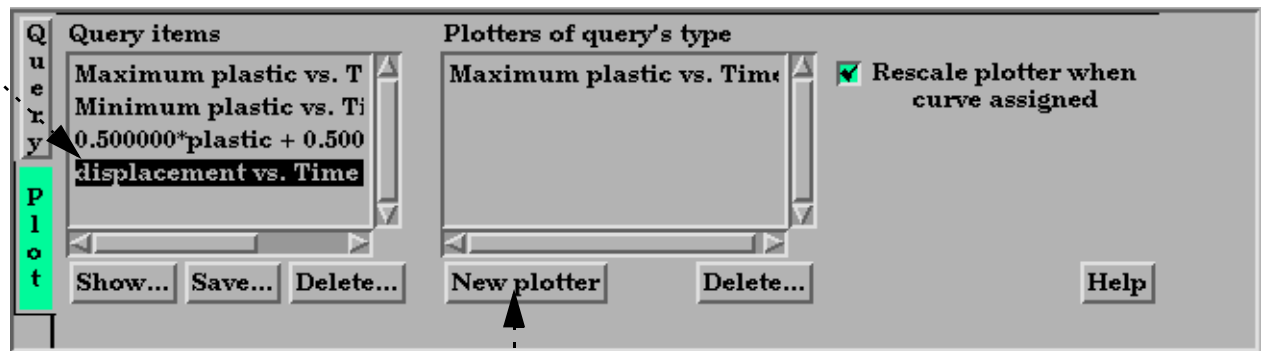

3. Select the next Query Item to be plotted.

4. Select the existing plotter on which to add this query plot.

In this case, the Minimum plastic vs. Time query is added to the existing plot for Maximum plastic vs. Time - thus the plotter will now have two curves on it.

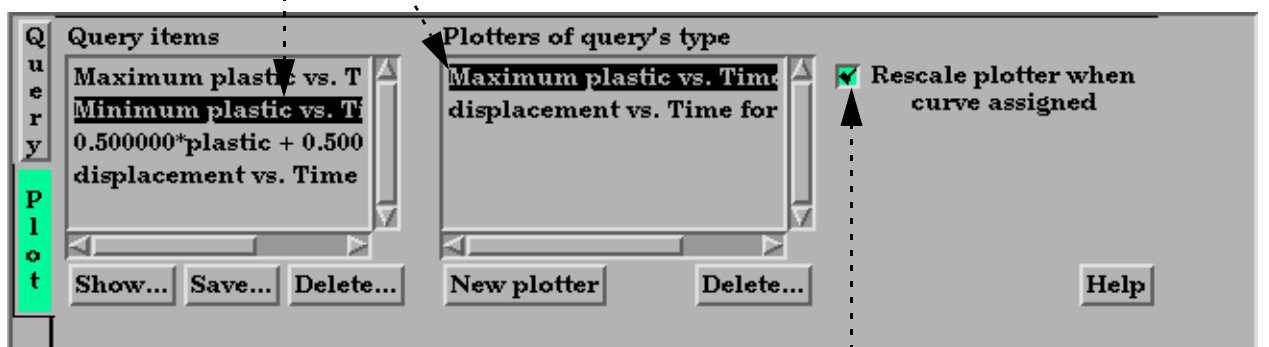

Note: the toggle indicated controls whether the plot is automatically rescaled whenever a curve is assigned to it, or not.

OTHER NOTES

See [XY Plot Data Format](#) in the User Manual for a description of the plot file format.

SEE ALSO

[How To Probe Interactively](#)
[How To Change Plot Attributes](#)

User Manual: [Query/Plot](#)



Change Plot Attributes

INTRODUCTION

EnSight provides a full-featured X-Y plotting system fully integrated with the query and transient data handling capabilities. Query entities (see [How To Query/Plot](#)) are assigned to *plotters*. Plotters display one or more curves where each curve is based on the data from a single query entity. If the query entity is changed, the corresponding curve will automatically update. Plotter attributes (controlling aspects of appearance such as color of curves and titles, axis labeling, gradation and tick marks, and border/background color) can be edited in Plot Mode.

This article is divided into the following sections:

- [Anatomy of a Plotter](#)
- [Create Plotters](#)
- [Select Plotters and Curves](#)
- [Move and Resize Plotters](#)
- [Set Plotter Visibility](#)
- [Set Title, Background, Legend, Border, Position, Time Attributes](#)
- [Set Axis Attributes](#)
- [Set Curve Attributes](#)
- [Delete Plotters](#)

Anatomy of a Plotter

Plotters are composed of the following fundamental components:

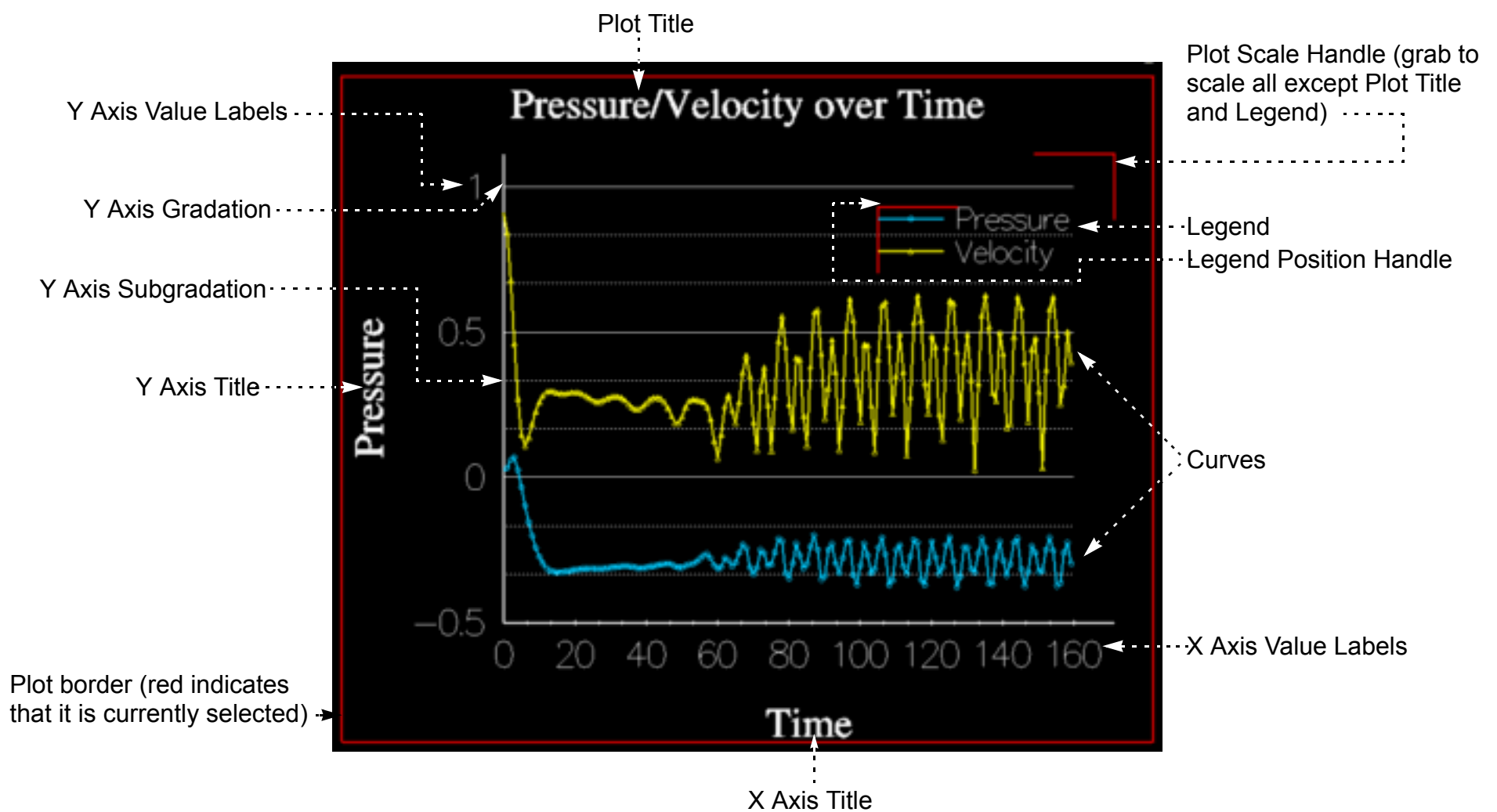



Create Plotters

Plotters are automatically created when you assign a query entity to a new plotter (see [How To Query/Plot](#) for details).

Select Plotters and Curves

When you create a new plotter, it automatically becomes the *currently selected plotter* (as shown by the border drawn in the default highlight color). Any action to change plotter attributes always operates on the currently selected plotter(s) (or the plotter defaults if none are selected). To select plotters:

1. Click **Plot** in the **Mode Selection** area to enter **Plot mode**.
2. Move the mouse pointer into the **Graphics Window** and click the left mouse button anywhere within the desired plotter. You can add to an existing selection by holding down the **Control** key as you click in additional plotters.

Since plotters may contain multiple curves, it is necessary to select individual curves within a plotter for subsequent action. If no curves are selected, changes to curve attributes reset the defaults for subsequently created curves. To select curves within a plotter:

1. Click **Plot** in the **Mode Selection** area to enter **Plot mode**.
2. Move the mouse pointer into the **graphics window** and click the left mouse button on the desired curve. You can add to an existing selection by holding down the **Control** key as you click on additional curves.

Move and Resize Plotters

Plotters can be easily moved and resized. You can either reposition a plotter with the mouse in the **Graphics Window**, or precisely by entering exact values. To move or resize a plotter interactively:

1. Click **Plot** in the **Mode Selection** area to enter **Plot mode**.
2. Select the desired plotter (as described above).
3. To move a plotter, move the mouse pointer into the **Graphics Window** and into the selected plotter. Click and hold the left mouse button and drag the plotter to the desired location.
4. To resize a plotter, move the mouse pointer into the **Graphics Window** and place it over one corner or side of the selected plotter. Click and hold the left mouse button and drag the corner or side to the desired location.

A plotter can also be positioned precisely. See [below](#) for details.

Set Plotter Visibility

Selected plotters can be made invisible:

1. Click **Plot** in the **Mode Selection** area to enter **Plot mode**.
2. Select the desired plotter(s).
3. Click the **Plotter Visibility Toggle** to toggle display of the selected plotters on or off (when not in **Plot Mode**).

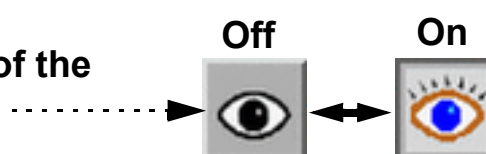

Plotters that are currently invisible are displayed dimmed while in **Plot mode**.



Set Title, Background, Legend, Border, Position, Time Attributes

Overall attributes of plotters are controlled through the Plotter Specific Attributes dialog:

1. Click **Plot** in the **Mode Selection** area to enter Plot mode.
2. Select the desired plotter(s).
3. Click the **Graph Attributes** icon.

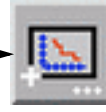

The Plotter Specific Attributes dialog contains six sections: Background, Border, Legend, Position, Time, and Title. Click the tab at the top to display the corresponding section.

The Background section controls the type and color of the plotter background:

Set background type to either None or Solid. A solid background is opaque.....

If the background type is Solid, set the color (either enter new values in the RGB fields or click the Mix... button to open the [Color Selector](#) dialog).

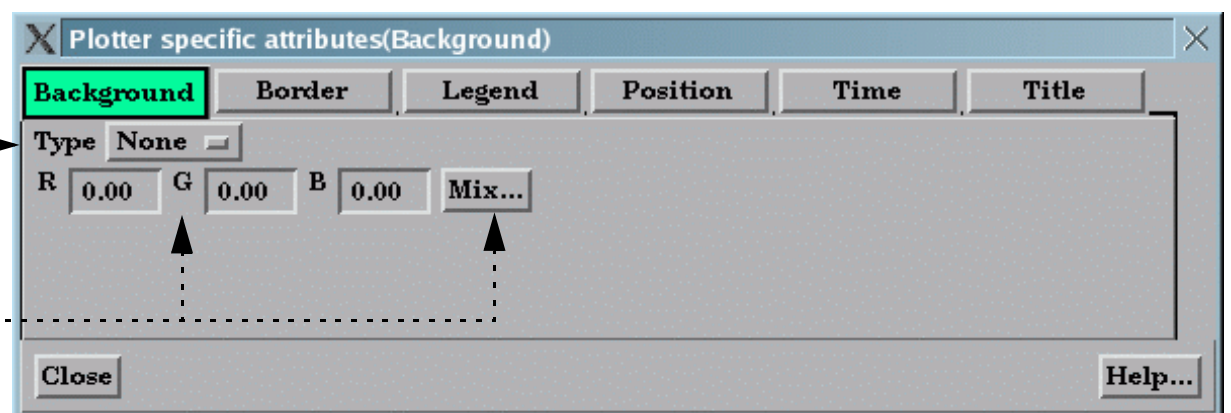

The Border section controls the visibility and color of the plotter border:

Toggle border visibility.....

Set border color (either enter new values in the RGB fields or click the Mix... button to open the [Color Selector](#) dialog).

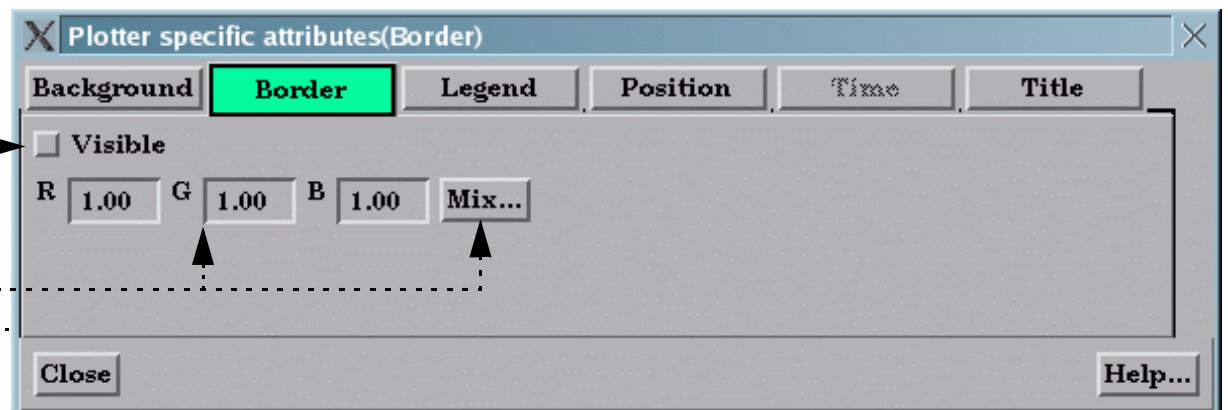

The Legend section controls the plotter legend text. The actual text in the legend is specific to the individual curves displayed in the plotter. See [Set Curve Attributes](#) below.

Toggle legend visibility.....

Set text size.....

Set origin (with respect to lower left corner of plotter).....

Set text color (either enter new values in the RGB fields or click the Mix... button to open the [Color Selector](#) dialog).

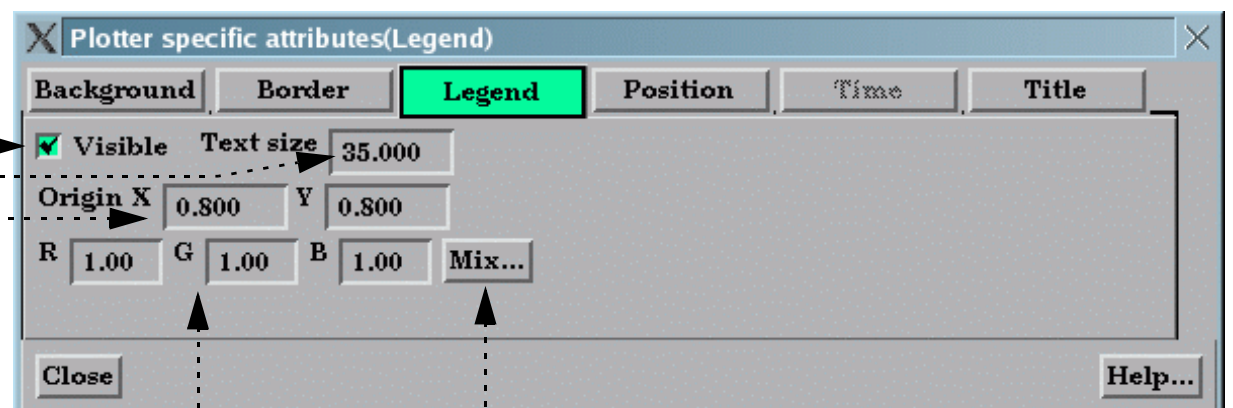



The Position section controls the size and position of the plotter:

Set the origin of the plotter (with respect to the lower left corner of the Graphics Window).....

Set the plotter width/height (0-1 normalized to the width and height of the Graphics Window).....

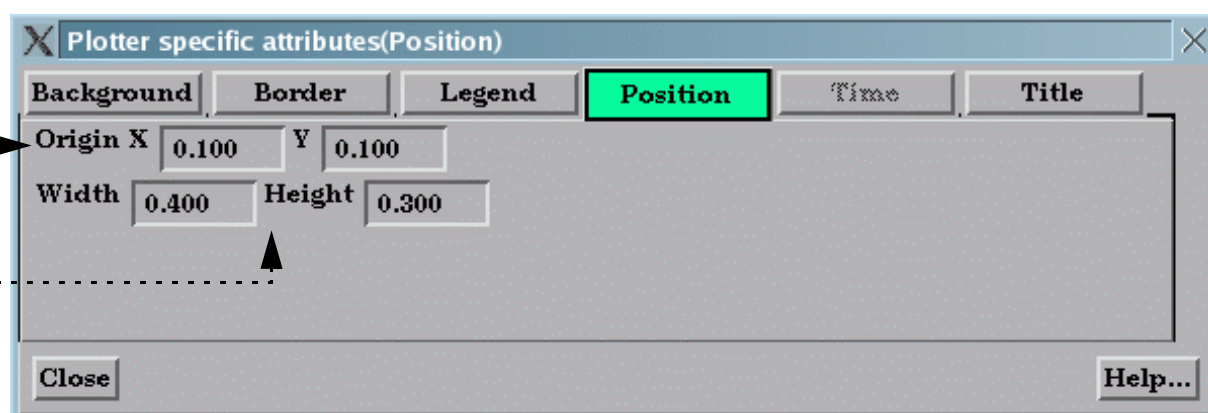

The Time section controls whether the curves will animate and whether the plot will be swept out during the animation or whether a time marker will sweep along the curve in the plotter:

Select Animate curves if you want the curve to be swept out or a time marker to be swept along the curve during animation.....

Toggle Display time marker on if you want a vertical line to sweep along the curve during animation. Otherwise the curve itself will be swept as animation proceeds.

You can control the line width, style, and color of a time marker.....

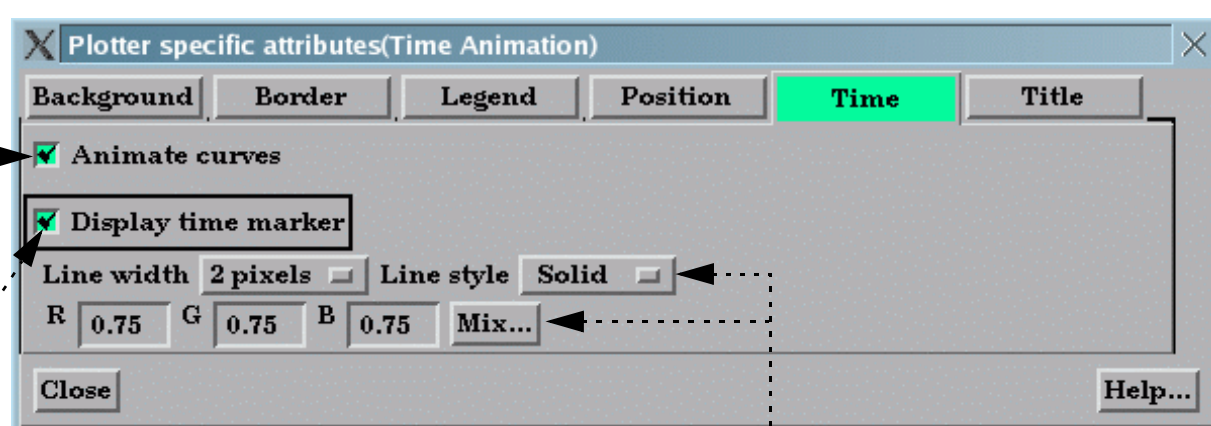

The Title section controls the main title at the top of the plotter (remember to press return after changing a text field):

Set title text.....

Set the size of the title text.....

Set the text color (either enter new values in the RGB fields or click the Mix... button to open the [Color Selector](#) dialog).....

If you desire special symbols, click Insert Symbol, pick the symbol(s), close, then hit return in the title field.

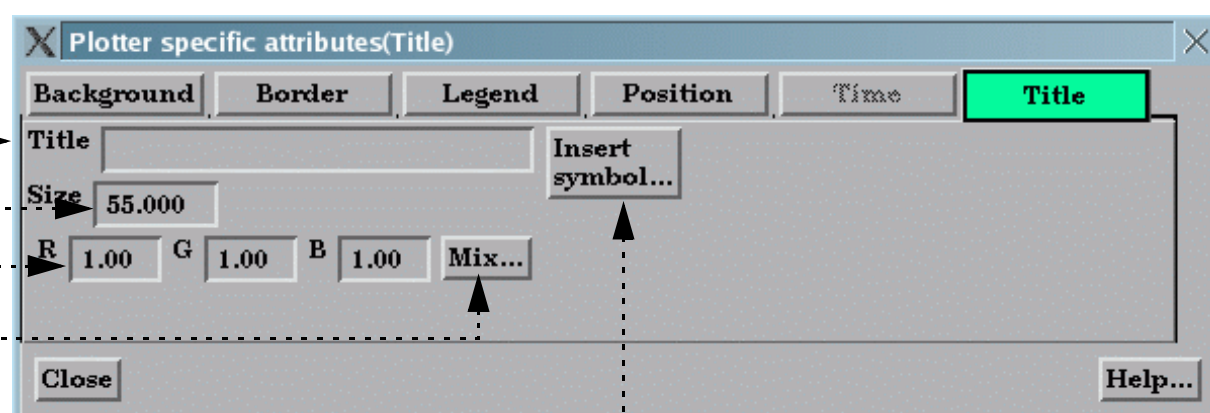



Set Axis Attributes

Axis attributes of plotters are controlled through the Axis Specific Attributes dialog:

1. Click Plot in the Mode Selection area to enter Plot mode.
2. Select the desired plotter(s).
3. Click the Axis Attributes icon.

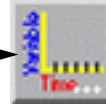

The Axis Specific Attributes dialog contains three sections: General, X-Axis, and Y-Axis. Click the button at the top to display the corresponding section.

The General section controls axis width, color, and scaling as well as Gradation and Subgradation marks.

Set line width of axes

Set color of axes

Set auto scaling - when on, the Min/Max values and the number of gradations (attributes for the X-Axis and Y-Axis) will be used as suggested values to arrive at pleasing numbers for the axis labels.

Set line width, style, and color for major gradations (gradations are enabled on a per-axis basis in the X-Axis and Y-Axis sections)

Set line width, style, and color for subgradations (subgradations are enabled on a per-axis basis in the X-Axis and Y-Axis sections)

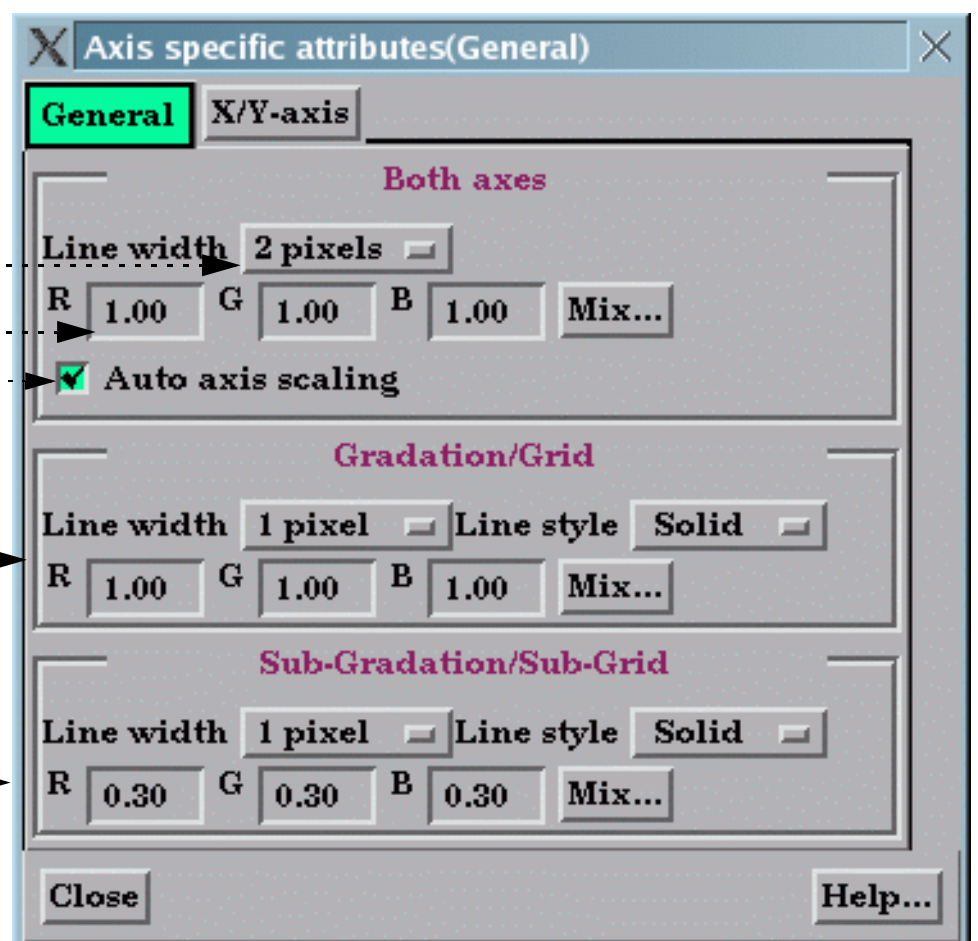



The X/Y-Axis section controls the title, value labels, and gradation marks for the X or Y axis..

Choose which axis to deal with.....

Toggle visibility of the axis line.....

Set the origin location of the plot (with respect to the left/
bottom edge of the plotter).....

Set the width/height of the plot (with respect to the width/
height of the plotter).....

Set the title of the axis.....

Set the size of the title of the axis.....

Set the color of the title of the axis.....

Set the type of axis label: None (show no value labels), All
(show value labels at each gradation), or Beg/End (show
only the first and last value labels).....

Set the size of the axis value labels.....

Set the scale to linear or logarithmic(log10).....

Set the min/max range of the variable displayed on the axis
(Note: will be used as exact values only if the Auto Axis
Scaling toggle under the General Section is off.).....

Set the display format of the value labels (or click Format...
to select common formats from a list).....

Set the color of the axis value labels.....

Set the type of gradation: None (no gradation marker), Grid
(a vertical line), or Tick (a mark on the axis at the value label
positions).....

Set the approximate number of gradations (also depends on
the min/max range).....

Set the type of subgradation: None (no subgradation
marker), Grid (a vertical line), or Tick (marks on the axis
between the value label positions).....

Set the number of subgradations between each value label.....

By swapping the min and max can swap the positive
direction.....

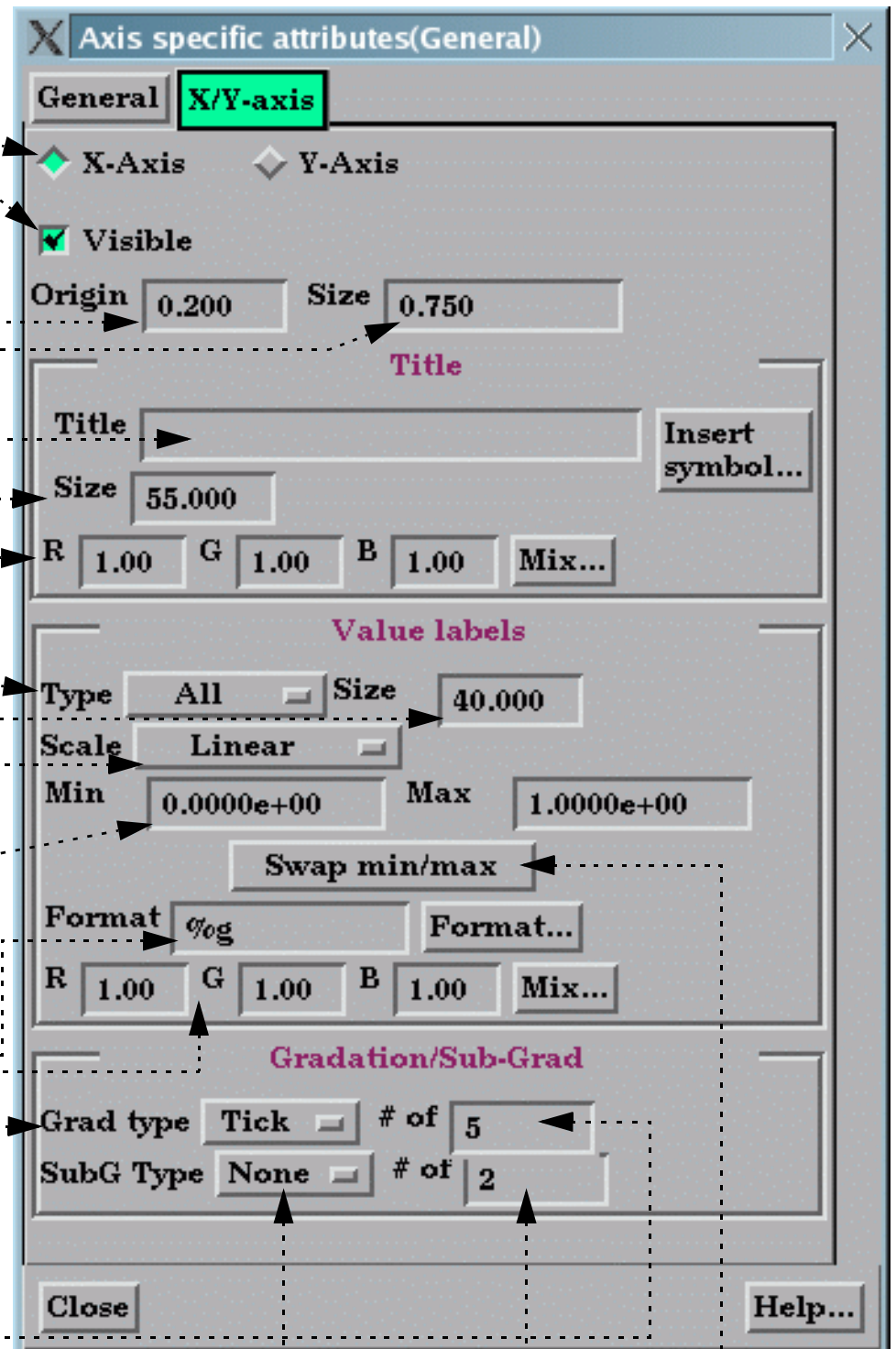



Set Curve Attributes

Curve attributes are controlled through the Curve Specific Attributes dialog:

1. Click **Plot** in the **Mode Selection** area to enter **Plot** mode.
2. Select the desired curve(s) by clicking on them in the **Graphics Window** (control-click to select multiple curves).

If no curves are selected, any changes are applied to the curve defaults which will effect any curves created in the future.

3. Click the **Curve Attributes** icon.

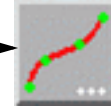

Set the description text for the curve (this will appear as the legend)

If desired, you can apply scale factors to your x and/or y data

Set the line width

Set the line style

Set the line type:

- None (only curve markers are drawn),
- Connect Dots (data points are connected by straight lines),
- Smooth (a piece wise spline is fit to the data points using the number of points specified in the Smooth Sub-points field)

Set the marker type

Set the size of the markers

Normalize x and/or y values, if desired.

Set the color of the curve.

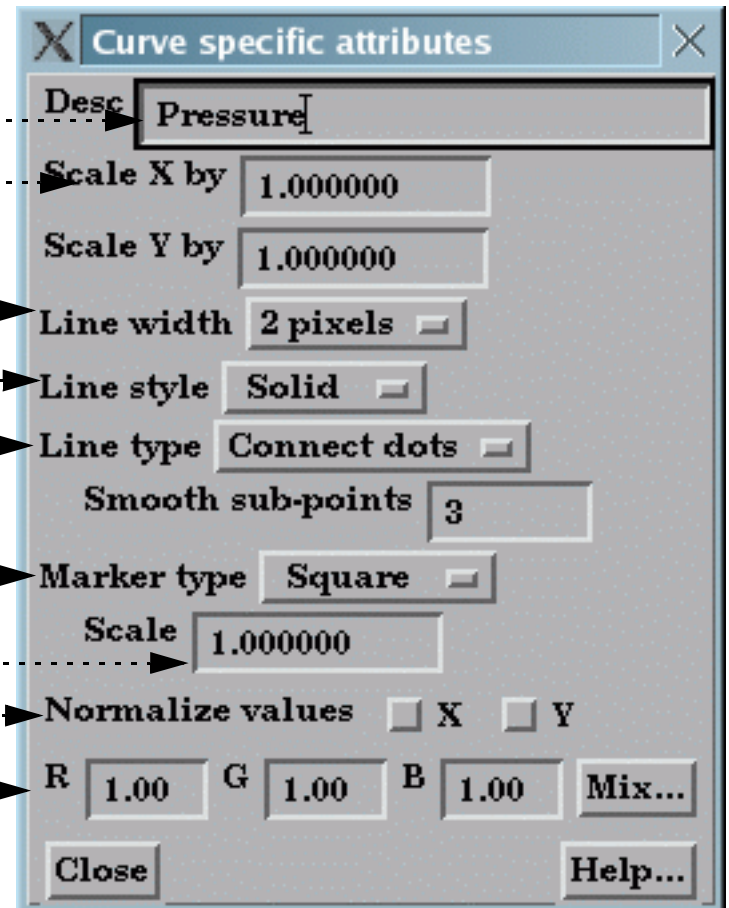

Delete Plotters

Existing plotters can be deleted:

1. Click **Plot** in the **Mode Selection** area to enter **Plot** mode.
2. Select the desired plotter(s).
3. Click the **Delete** icon.



Note that deleting a plotter has no effect on any query entities that were attached to the plotter

Select All

You can select all curves or all plotters.

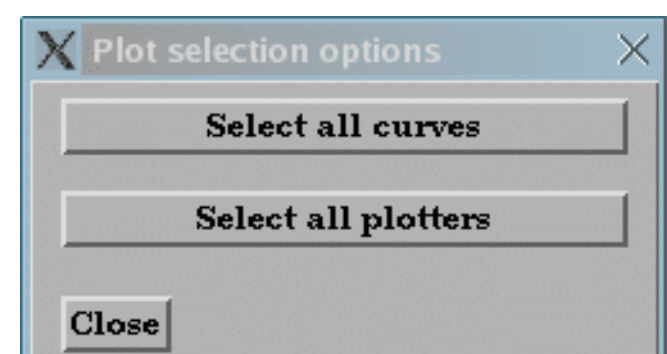



SEE ALSO

[How To Query/Plot](#)

User Manual: [Plot Mode](#)





Query Datasets

INTRODUCTION

Results datasets often consist of multiple files. EnSight provides a mechanism to quickly ascertain basic information about dataset files.

BASIC OPERATION

To display dataset information:

1. Select Query > Dataset...

The Associated Files section displays all dataset files giving the size in bytes and last modification date.

The File Specific Information section displays information about the file currently selected in the Associated Files list. The information presented varies based on the file type and format.

The General Geometric section displays the 3D extent of all geometry as well as the number of nodes and elements.

The Element Detail section shows the type and number of all unique element types in the dataset.

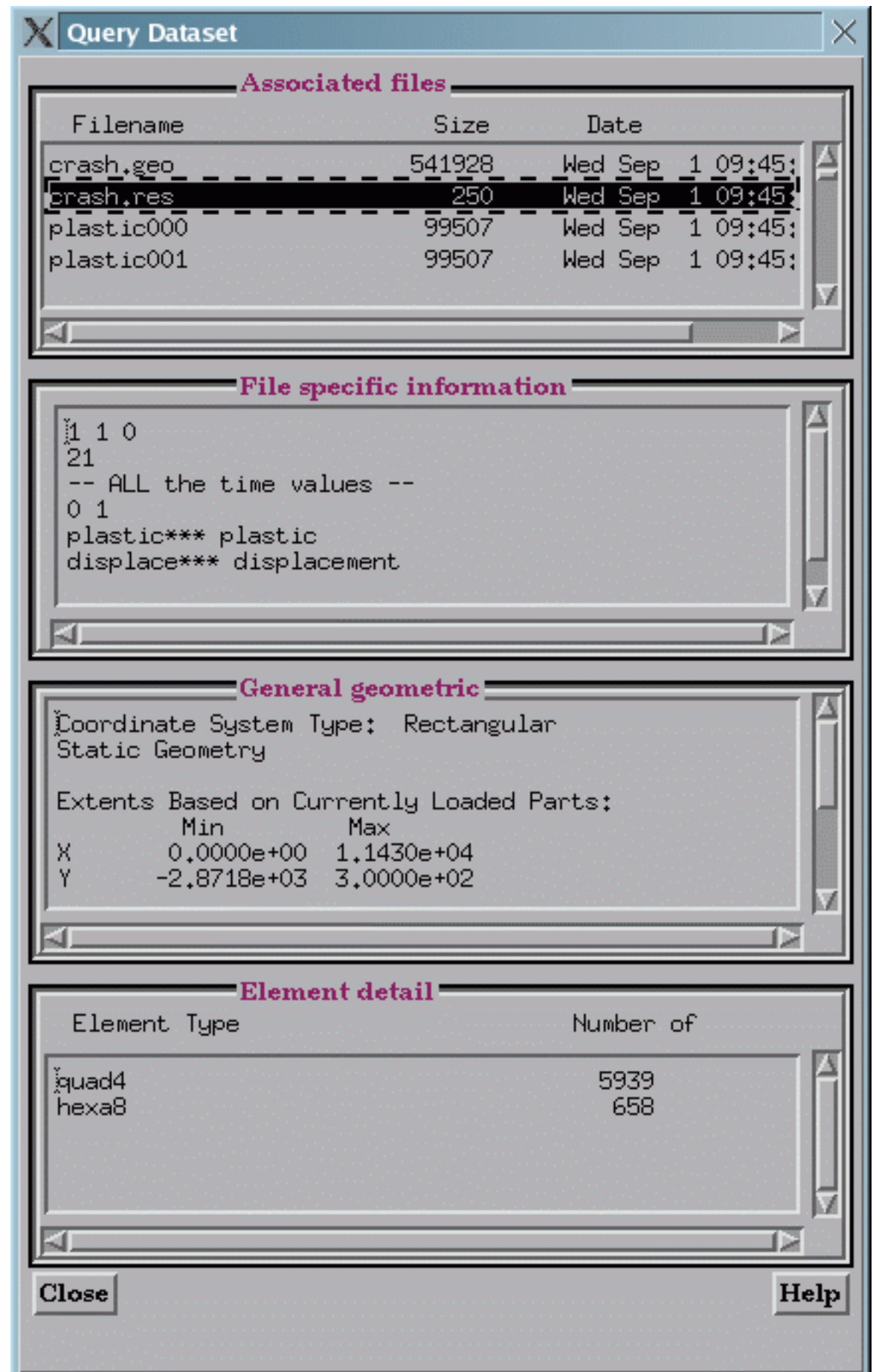

SEE ALSO

User Manual: [Query Dataset](#)





Manipulate Parts
Change Color

INTRODUCTION

In EnSight, parts can be colored either by a constant color or based on the value of a variable. Coloring geometry by variables is one of the simplest and most effective means of visualizing the distribution of a variable.

You can also set a “default” color – all parts subsequently created will automatically be colored by the default color (described in the Other Notes section below).

This article covers changing the color of a part. See [How To Edit Color Maps](#) for information on changing the mapping from variable values to color.

BASIC OPERATION

To change a part's color:

1. Select the desired part(s) in the Main Parts List.

2. Click the Color icon.

Which will open the Part Color dialog.



3. If coloring by a variable, select the variable in the Variables List.

– OR –

4. If coloring by a constant, either enter the desired RGB values in the appropriate fields (remember to press return)

or click the More... area to open the Color Selector dialog

As long as the Apply modifications immediately toggle is on, once step 3. or 4. is completed, the part(s) will immediately be colored appropriately in the graphics window. If this is toggled off, then the Apply button will need to be clicked in order to have the color change take place.

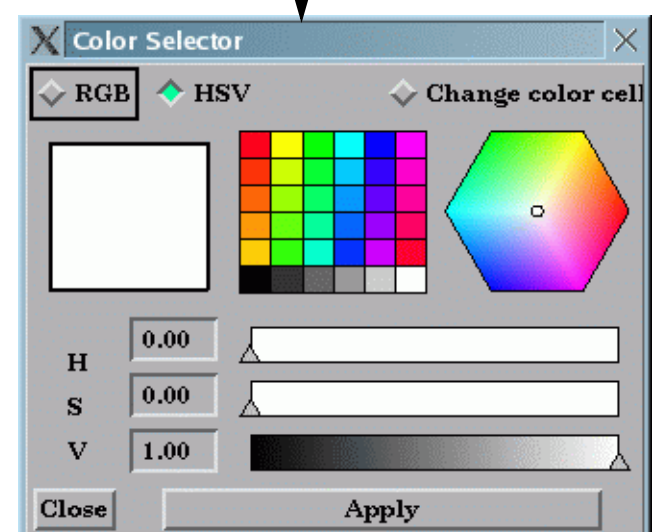
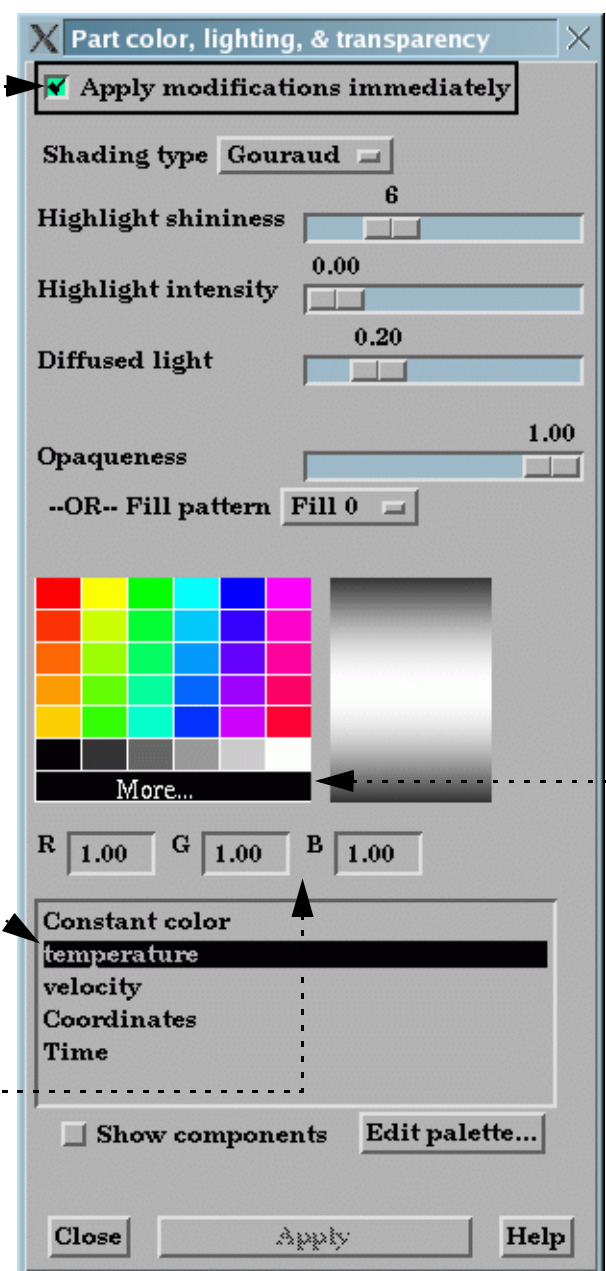



OTHER NOTES

You can set a default variable that will be used to color all subsequently created parts. To do this, be sure no parts are selected in the Main Parts list. (To de-select a part, hold down the control key as you click on the selected item.) Select the desired default variable in the Variables list of the Part color, lighting, & transparency dialog as described in 3. and 4. above. Any part created subsequently will automatically be colored by the default variable.

If you are coloring by a vector variable, you can choose whether to color by the magnitude (default) or (by showing the components in the list) you can choose to color by one of the components.

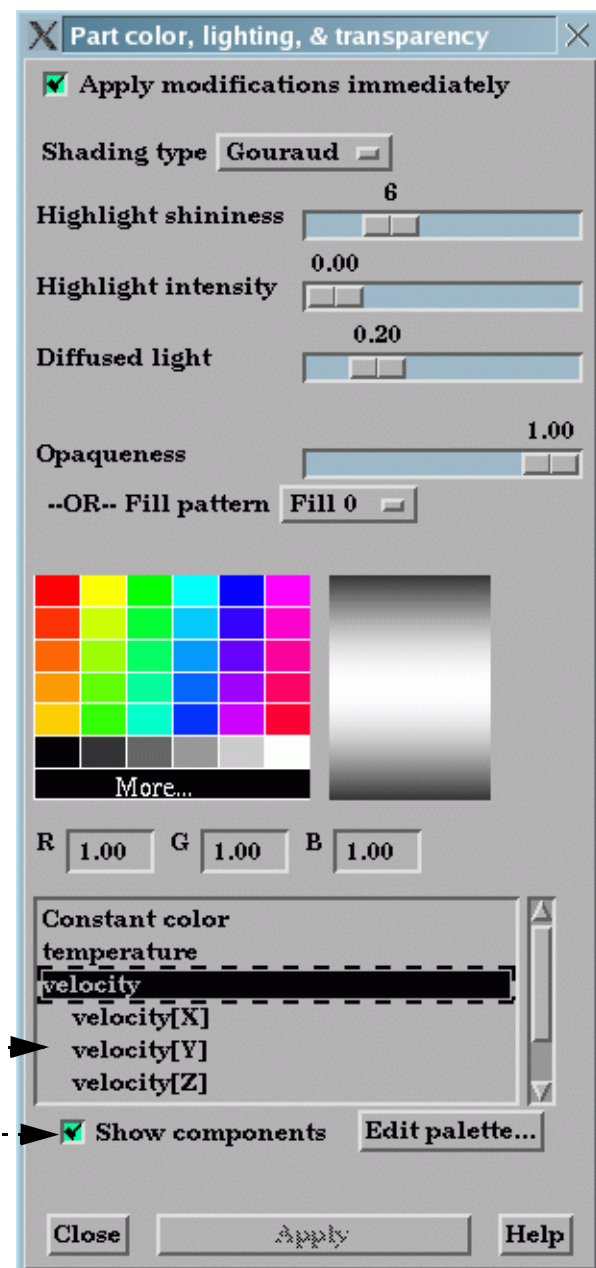

SEE ALSO

[How To Edit Color Maps.](#)

User Manual: [Color Selector](#)



Copy a Part

INTRODUCTION

The copy operation creates a *dependent* shallow copy of another part. The new part has its own set of attributes (except for representation), but shares geometric and variable data with the original. One of the best reasons to create a copy is to show multiple variables on one part at the same time in a side-by-side configuration. The copy can be moved independently since new copies are automatically assigned a new **frame**.

BASIC OPERATION

To create a copy of a part or parts:

1. Select the desired part(s) in the Parts List. A separate copy will be created for each selected part.

2. Select Edit > Part > Copy...

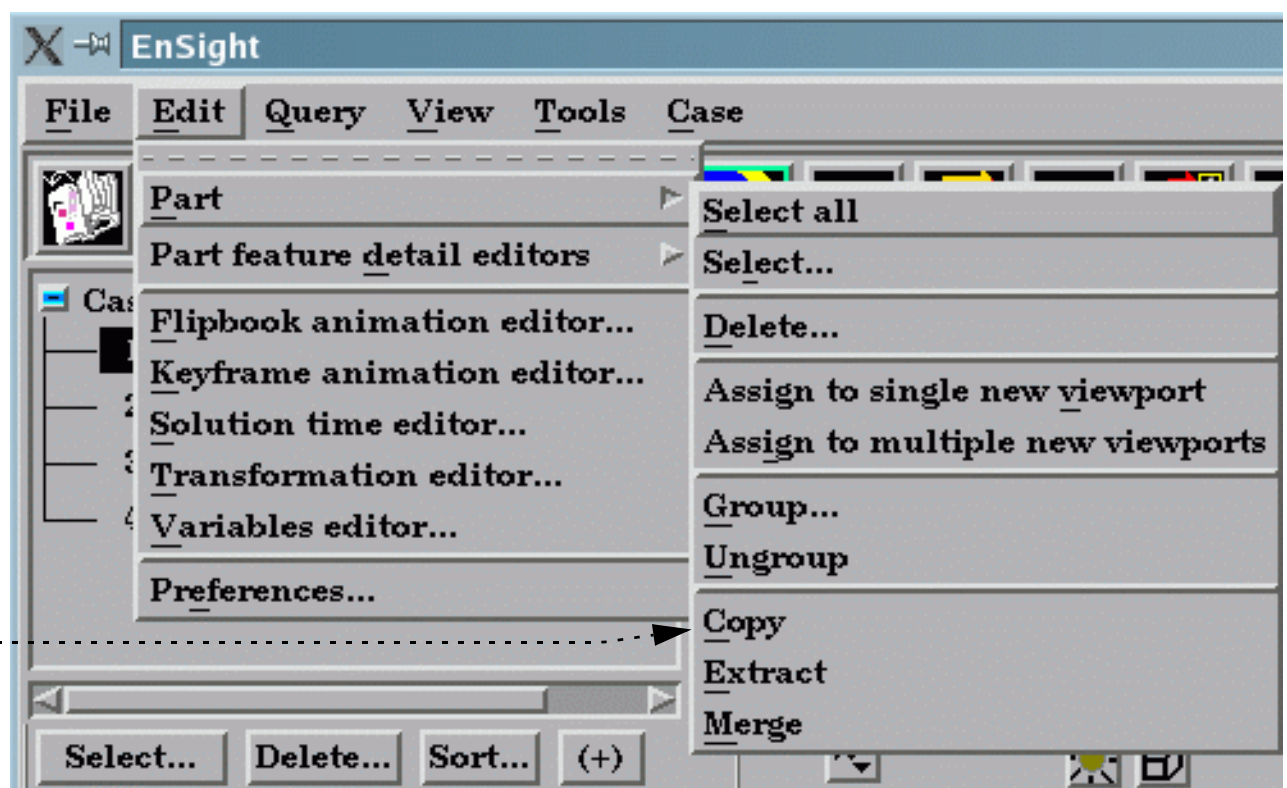

The new copies will be added to the end of the Parts List with “– COPY” appended to the part description.

ADVANCED USAGE

The most common reason for needing a copy of a part is to display multiple variables on the same geometry simultaneously. When you create a copy, a new Frame is also created and the copy is assigned to it (when you create multiple copies at the same time, a new frame is created for *each* new copy). Using Frame Mode, frames can be manipulated (e.g. translated or rotated) independently. See [How To Create and Manipulate Frames](#) for more information.

OTHER NOTES

The dependence of the copy on the original has some important consequences:

1. If you change the **visual representation** of the original, the representation of the copy will change as well.
2. You cannot delete the original until the copy has also been deleted.
3. Since the part copy only exists on the client, you cannot save a part copy to disk.

If you want to create a dependent, non-shallow copy of a part, you can perform a **merge** operation on a single part. This type of copy does now have the same consequences: the resulting “copy” is basically independent except that it cannot exist without its parent.

SEE ALSO

User Manual: [Part Operations](#)





INTRODUCTION

In many types of analysis, multiple parts are used to distinguish between various components or material types. To the extent allowed by the particular data format, EnSight maintains this distinction by assigning these entities to separate model parts. In many cases however, this distinction is no longer useful for postprocessing. When manipulating parts, you often need to apply the same set of attributes to all of them. If the number of parts to be treated identically is large, this process can become unwieldy. EnSight provides a group operator to combine multiple parts of the same type and case into a single part. The selected parts for the group are automatically removed from the user interface, leaving only the newly formed group part. The operation can be reversed by performing the Ungroup command.

BASIC OPERATION

1. Select the desired part(s) in the Parts List.

2. Select Edit > Part > Group (or right click in the part list)

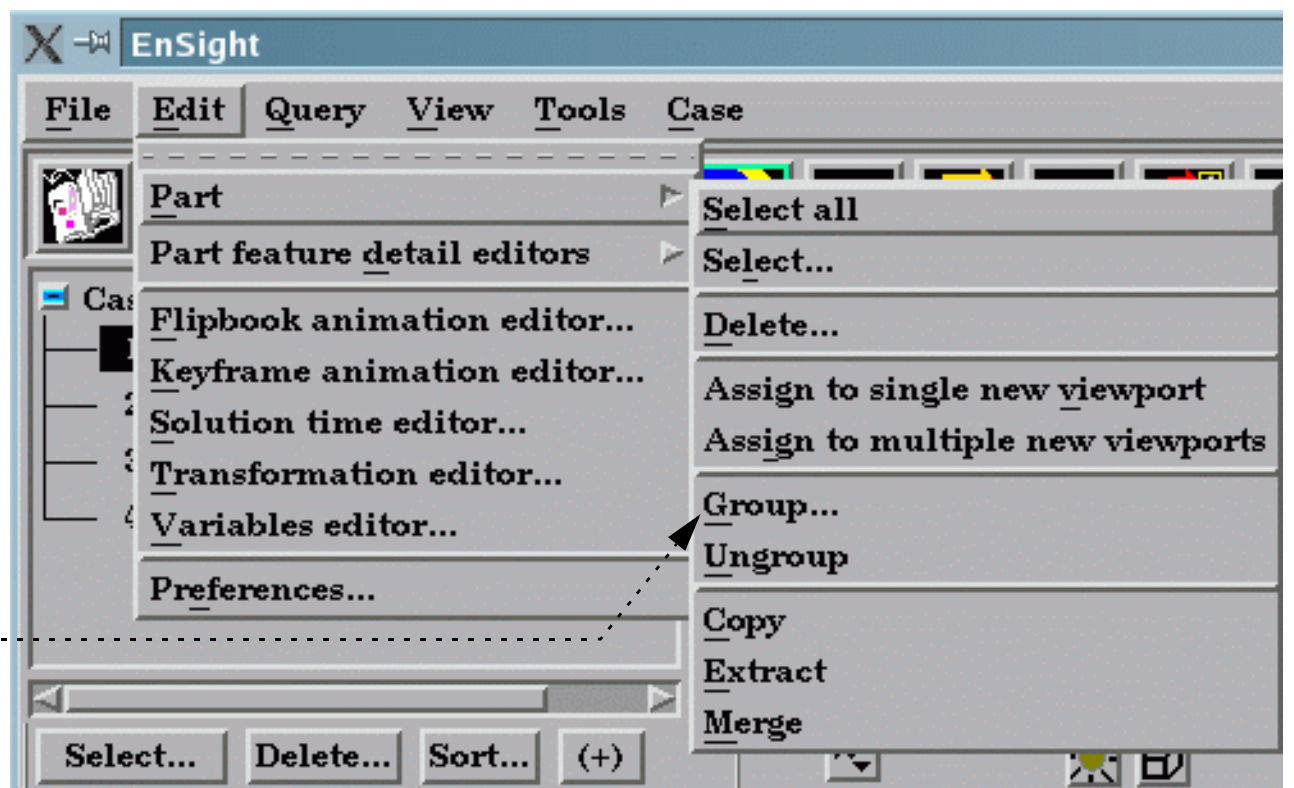

3. Enter a new part name in the pop-up dialog.

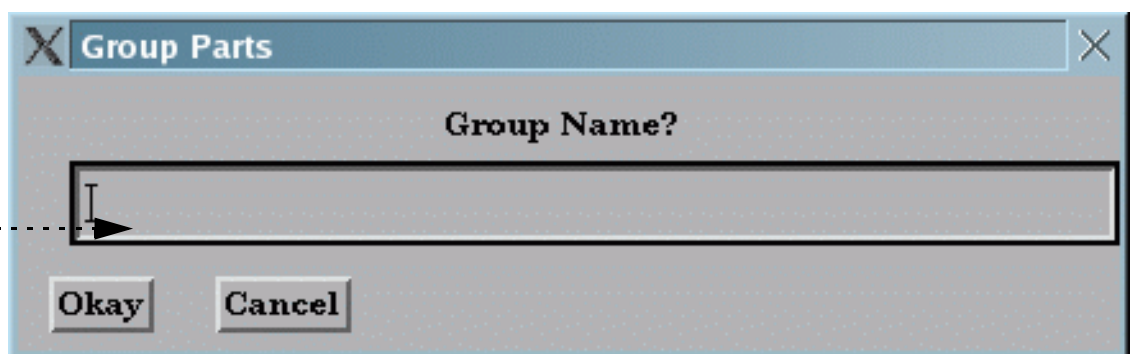

The selected parts for the group are removed from the part list, and a new Group part is added to the end of the Parts List.

OTHER NOTES

The operation can be reversed by selecting Edit > Part > Ungroup

Grouped parts cannot contain other grouped parts.

SEE ALSO

User Manual: [“Part Operations”](#)



INTRODUCTION

In many types of analysis, multiple parts are used to distinguish between various components or material types. To the extent allowed by the particular data format, EnSight maintains this distinction by assigning these entities to separate model parts. In many cases however, this distinction is no longer useful for postprocessing. When manipulating parts, you often need to apply the same set of attributes to all of them. If the number of parts to be treated identically is large, this process can become unwieldy. EnSight provides a merge operator to combine multiple parts into a single part.

The merge operation creates one new part from one or more selected parent parts. The original parts are unchanged. If only a single part is selected for the operation, merge will create a “true” copy of the part (as opposed to the shallow copy that the **Copy** operation creates), with the only dependence being that the parent must exist.

If you delete any of the original parts after the merge, these components will be deleted from the merged part as well.

BASIC OPERATION

1. Select the desired part(s) in the Parts List.

2. Select Edit > Part > Merge

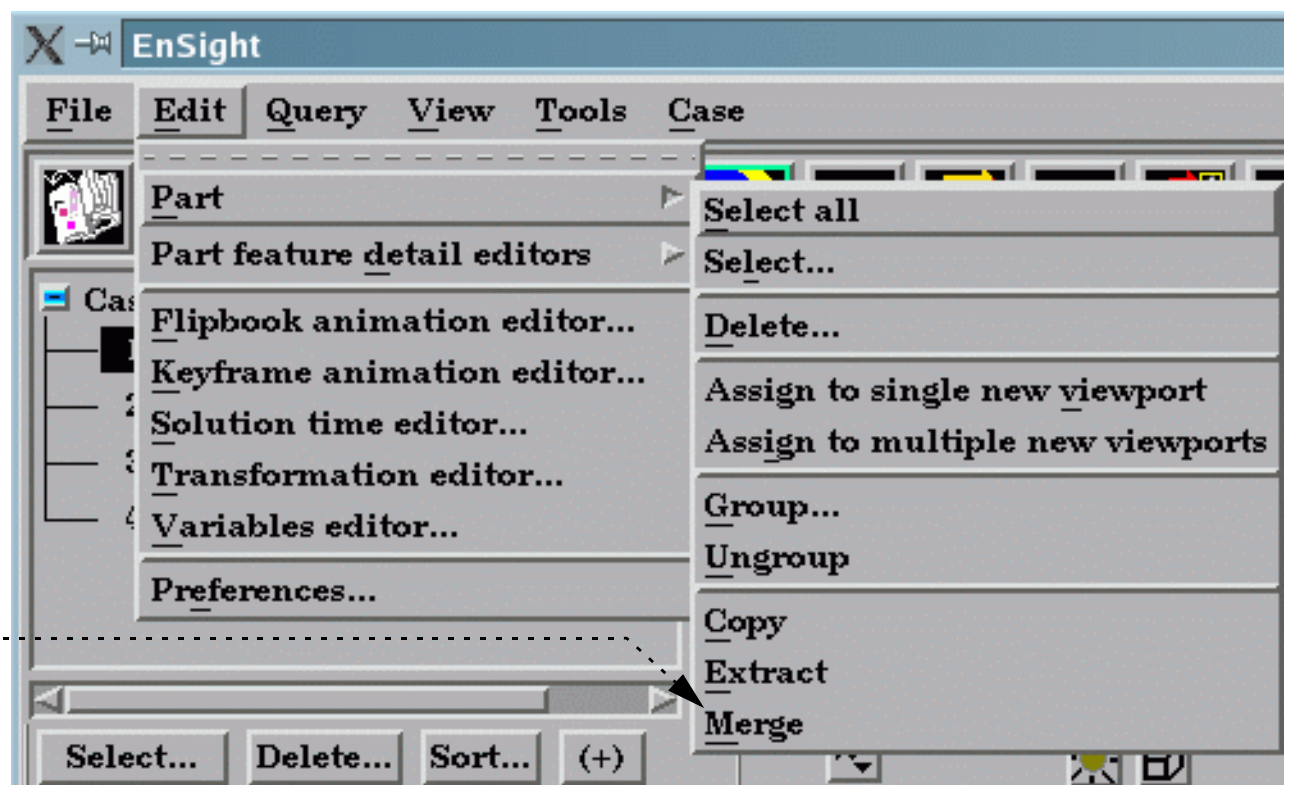

The new merged part is added to the end of the Parts List with the description “Merge of parts #,#,#” where # are the part numbers of the originally selected parts.

OTHER NOTES

Unlike **Copy**, merge creates true, server-based parts. Unlike **Extract**, merge creates parts based on the full, server-based representation of the part.

If you merge a structured (IJK) part, the resulting part will be unstructured.

SEE ALSO

[How To Group Parts.](#)

User Manual: “[Part Operations](#)”

INTRODUCTION

The extract operation is closely tied to part **representations**. Extract creates a single new part using only the geometry of the *current representation* of the selected part(s). For example, if the current representation of a part consisting of 3D elements is Border, the result of extraction will be a part consisting of all unshared 2D elements (the surface).

Extract is most often used to reduce the amount of information for a part (e.g. for faster display or for **geometry output**) or to create a surface shell part – perhaps for subsequent cutting – of a 3D computational domain.

BASIC OPERATION

1. Select the desired part(s) in the Parts List.

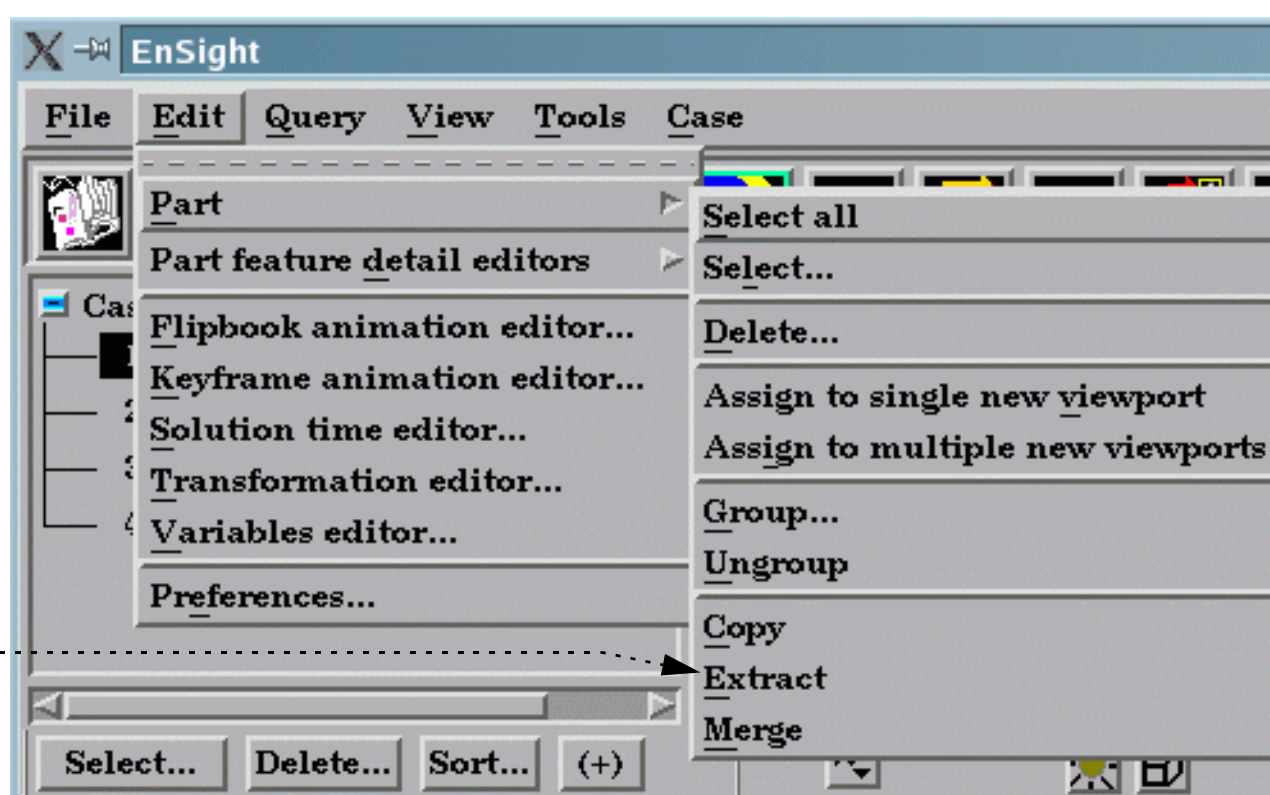

2. Select Edit > Part > Extract.

The new part is added to the end of the Parts List with the description “Extract of parts #,#,#” where # are the part numbers of the originally selected parts.

SEE ALSO

See [How To Change Visual Representation](#).

User Manual: [“Part Operations”](#)



INTRODUCTION

It is sometimes desirable to cut parts to, for example, reveal the interior of a solid or remove unwanted or unneeded portions of a model. EnSight can cut any server-based part and either keep both “sides” or discard one. Any of the 3D tools (Plane, Quadric, or Box) can be used as the cutting surface.

The cut operation produces dependent copies of the parent part. The part(s) resulting from a cut are completely valid parts consisting of standard element types. These parts can be used for any operation – including further cuts.

BASIC OPERATION

To cut a part:

1. Select the part(s) in the Main Parts list.

2. Click the Clip Feature icon.



3. Select the desired cutting tool ([Plane](#), [Box](#), [Cylinder](#), [Sphere](#), [Cone](#), [Surface of Revolution](#) or [Revolve 1D Part](#)).

4. Position the desired cutting tool in the desired location.

5. Select which “sides” to keep.

Inside: Keeps inside of quadrics or box and “front” of plane.

Outside: Keeps outside of quadrics or box and “back” of plane.

In/Out: Keeps both sides

Crinkly: Keeps all elements that intersect the plane.

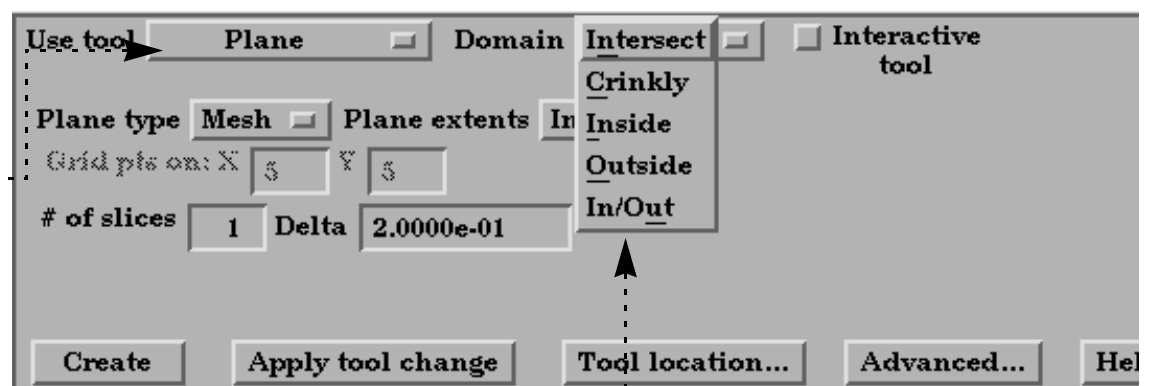

For the Plane tool, the inside is the positive Z side of the tool. For the quadric tools, the inside and outside are intuitive. In the Main Parts list, the original part remains and cannot be deleted without also deleting the cut parts (but can easily be made invisible if desired). If In/Out was used, two new parts are added to the end of the Main Parts list with the same name as the original part with “+” added to the name of the Inside part and “-” appended to the name of the Outside part. If Inside or Outside was used, one new part is created with “+” added to the beginning of the name.

OTHER NOTES

A part [copy](#) cannot be cut. However, if the parent of the copy is cut, the copy will be cut as well (since part copies share geometry with the parent).

The cut operation maintains the order of the elements, e.g. 3D elements yield 3D elements and 3D quadric elements yield 3D quadric elements.

The cut algorithm breaks elements intersecting the cutting surface into tetrahedrons. Since there is no transition zone created between these tetrahedrons and their non-cut neighbors, non-shared element faces are possible. These non-shared faces can result in undesired lines and/or elements during border and/or feature angle representations.

If you cut a structured (IJK) part the resulting parts will be unstructured.

Cuts with the Box are not true cuts, but simply a division of all elements that fall completely within the box or not.

SEE ALSO

User Manual: [Part Operations](#)



Delete a Part

INTRODUCTION

The delete operation removes selected parts and *any parts dependent on them*. All information associated with the parts on both the client and server is removed. Deletion cannot be undone.

BASIC OPERATION

1. Select the desired part(s) in the Parts List.

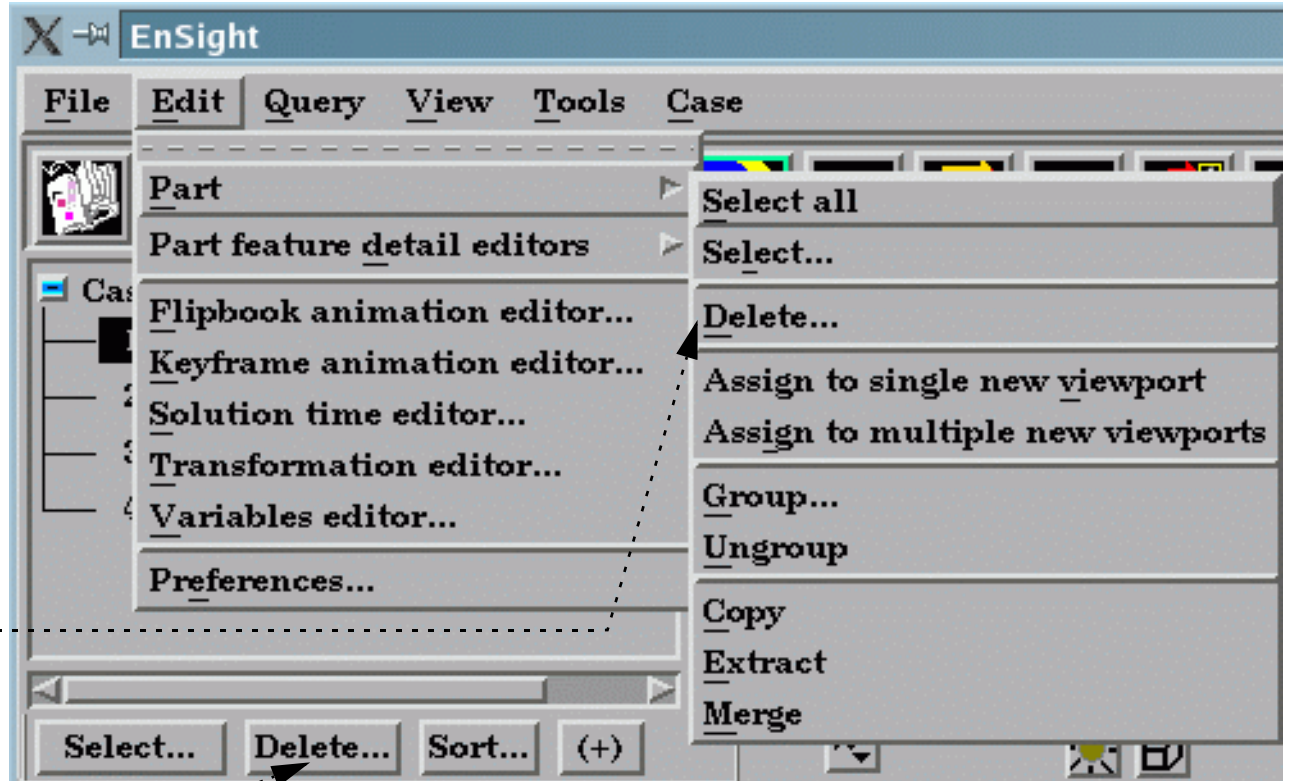

2. Select Edit > Part > Delete.

or click the Delete... button below the main parts list

or click the Delete key on your keyboard while the mouse is in the EnSight window

or right click and select Delete.

3. Confirm the deletion.

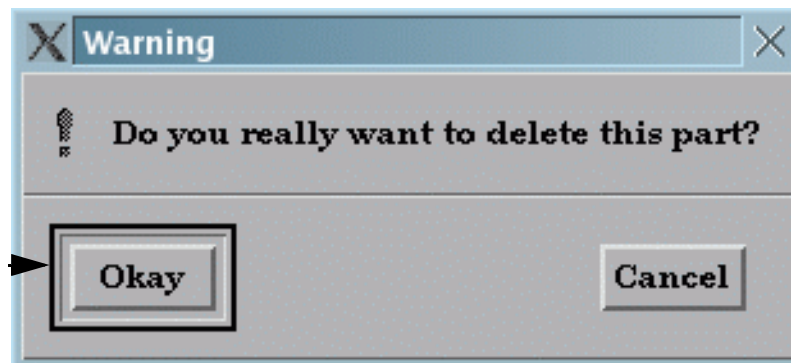

OTHER NOTES

In some cases, variables that depend on a deleted part may have to be updated. For example, if you have a variable such as Area calculated on a set of parts and one of the parts is deleted, the Area variable will automatically be recalculated.

If you delete a grouped part, all parts in the group will be deleted.

SEE ALSO

User Manual: [“Part Operations”](#)



Change the Visual Representation

INTRODUCTION

The ability to change part representations is a powerful management tool in EnSight. Not only can you select the visual representation that best meets your needs, you can also manage memory more effectively. Part representations exist on the client, the full part is maintained by the server. Using simpler representations both reduces your client memory consumption as well as improving graphics display speed.

EnSight provides five representation modes for parts (as well as three modes that are a combination of the five depending on the dimensional order of parts):

- Full* Every face and edge of every element is displayed.
- Border* Only unshared faces (for 3D parts) or unshared edges (for 2D parts) are displayed.
- 3D Border, 2D Full* Display 3D parts in Border representation; display 2D parts in Full representation. This is the default representation for all parts.
- 3D Feature, 2D Full* Display 3D parts in Feature representation; display 2D parts in Full representation.
- 3D nonvisual, 2D Full* Display 3D parts in Non Visual representation; display 2D parts in Full representation.
- Feature Angle* Only those edges joining faces in the Border representation for which the angle between the faces is less than some threshold are displayed. Feature Angle typically extracts the topological features of interest in a model.
- Bounding Box* Only a wireframe box representing the XYZ extents is displayed.
- Non Visual* No visual representation exists on the client. It is often useful to use Non Visual as the representation for 3D computational domain parts – provided you also have some sort of shell part to display the outer surface.

BASIC OPERATION

1. Select the desired part(s) in the Parts List.
2. Select Part in the Mode Selection area to enter Part mode.
3. Click the Element Representation icon to open the Part Element Settings dialog.
4. Select the desired visual representation.

Options are:



5. If desired, you can apply polygon reduction.

Polygon reduction is designed to speed up visualization processing by thinning out the number of polygons that are rendered. There is naturally a trade off in image quality and speed. Note that the original model is not modified, just its rendered image.

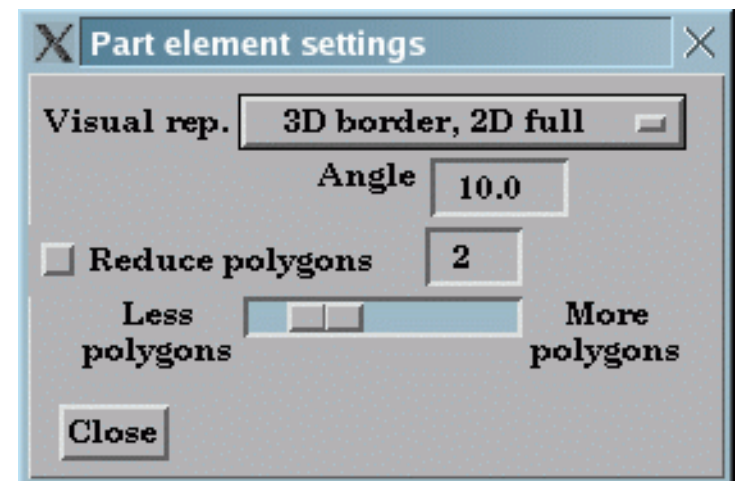

OTHER NOTES

Note that some derived parts (such as contours or vector arrows) are based on the client's representation of the parent part. If the parent's representation changes, the derived parts will change as well.

You cannot change the representation of a copied part. A copy always exhibits the current representation of the original part.

A part's representation can be made "permanent" by creating a new part based on the current representation. See [How to Extract Part Representations](#) for more information.

SEE ALSO

User Manual: [Element Representation](#)



INTRODUCTION

Part attributes control the appearance and behavior of parts. Much of the power of EnSight derives from the broad range of attributes available and the ease with which they can be changed. Attributes are grouped into several classes:

Creation	Creation attributes are unique for each (non-model) part type (e.g. the isovalue of an isosurface). Most (if not all) of the creation attributes for a part are accessible in the Quick Interaction area after double-clicking the part in the Main Parts List, or by the main menu structure Edit->Part Feature Detail Editors->Isosurfaces (for example).
General	<ul style="list-style-type: none"> Visibility Susceptibility to auxiliary clipping Reference Frame Response to change in time (active or frozen) Symmetry options Viewport visibility Coloration (by variable or constant color) Hidden surface toggle Hidden line toggle Shading type (flat, Gouraud, smooth) Transparency Lighting (diffuse, shininess, highlight intensity) Visual symmetry
Node, Element, and Line	<ul style="list-style-type: none"> Node, line, element visibility toggles Node type (dot, cross, sphere) Node scale (constant or variable) Node detail (for spheres) Node and element label toggle Element-line width Element-line style (solid, dotted, or dot-dash) Element representation on client (full, border, 3D border/2D full, 3D feature/2D full, 3D nonvisual/2d full, feature angle, bounding box, nonvisual) Element shrink factor Polygon reduction factor Failed element variable and rules
Displacement	<ul style="list-style-type: none"> Displacement variable Displacement scaling factor
IJK Axis Display	<ul style="list-style-type: none"> IJK Axis visibility IJK Axis scale value

Most (if not all) of the Creation attributes for non-model parts can be edited in the Quick Interaction area by double-clicking on the part in the Main Parts list. Most display attributes (such as color and visibility) can be controlled via the icons in Part mode. If required, the Feature Detail Editor can be opened for complete access to all attributes. See [How To Use the Feature Detail Editors](#) for more information.

Since Creation attributes are specific to each (non-model) part type, they are not covered here. Look in the How To article for the specific part type for details on those particular Creation attributes.

This article is divided into the following sections:

[Part Mode Attribute Icons](#)

[General Attributes](#)

[Node, Element, and Line Attributes](#)

[Displacement Attributes](#)

[IJK Axis Display Attributes](#)



BASIC OPERATION

Part Mode Attribute Icons

The Part mode icons can be used to quickly set attributes for parts. To use these controls:

1. Select the desired part(s) in the Main Parts list.
2. Click Part in the Mode Selection area.
3. Click appropriate icon to set the desired attribute:

P a r t		Part Visibility	
		Color, Lighting, & transparency	
	A n n o t		Line Width
			Visibility Per Viewport
		P l o t	
			Displacement
	V p o r t		Visual Symmetry
			Node and Element Labeling
	F r a m e		Node Representation
			Failed Elements
			Element Blanking
			Shading Type
			Hidden Line
			Auxiliary Clipping
			Fast Display Representation



General Attributes

The General Attributes section in the Feature Detail Editor duplicates many of the controls available in Part mode. To set attributes using the General Attributes section:

1. Select **Edit > Part Feature Detail Editors > part type**.

2. In the parts list at the top of the Feature Detail Editor dialog, select the desired part(s):

By default, any changes you make to attributes will take effect immediately. If you wish to “batch” a series of changes, select **Edit > Immediate Modification** (be sure to use the Edit menu in the Feature Detail Editor dialog) to toggle this setting off. When toggled off, a button at the bottom of the dialog becomes active: **Apply Changes**. Click it when you are ready to apply a set of changes.

3. Set the desired attribute(s):

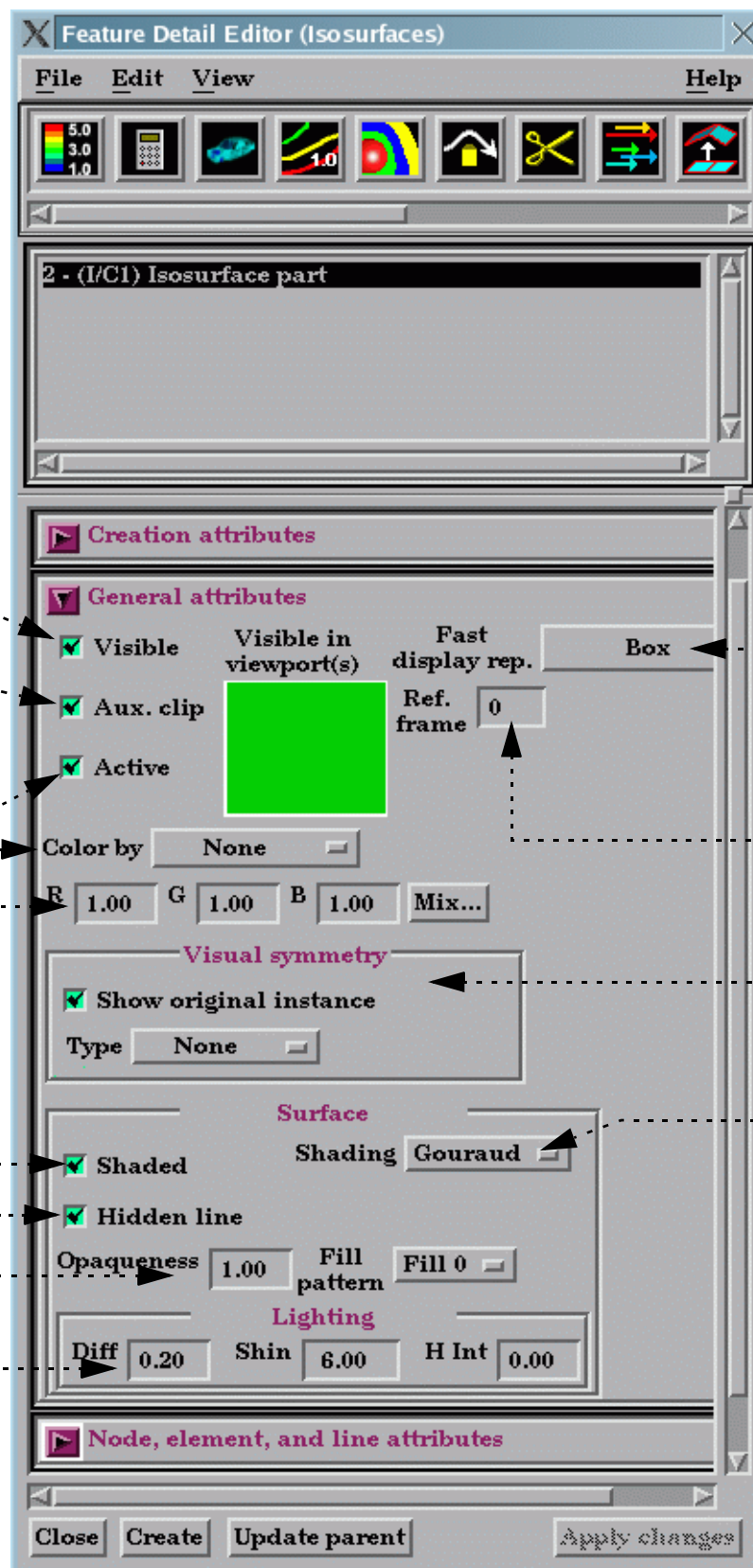

Toggle part visibility

Toggle **auxiliary clipping** on/off.

Toggle whether the client's portion of the part changes if the current time step changes

Set **color** by constant or color by variable

Set the part color if constant

Toggle part hidden surface

Toggle part hidden line

Set part **transparency** as “true” or with a fill pattern

Set part shading parameters:

- Diff: diffuse shading – the amount of light that a surface reflects. 0 is none and 1 is full.
- Shin: Degree of shininess – 0 is dull and 100 is very shiny.
- H Int: Degree of highlight intensity – 0 is none and 1 is full.

Set part detail representation (according to **Global Viewing Detail Mode**):

- Box: part is represented as bounding box.
- Elements: part is represented according to Element Representation
- Points: part is represented as a point cloud

Set part **reference frame**

Set part graphical **symmetry**

Set shading type:

- Flat: color and shading are constant across elements
- Gouraud: color and shading vary linearly across elements
- Smooth: color and shading calculated based on surface normal interpolated across elements to simulate a smooth surface.

SEE ALSO

[Set Global Viewing Parameters](#)



Node, Element, and Line Attributes

Node, element, and line attributes control how a part's nodes and elements are displayed. Nodes can be displayed as dots, crosses, or spheres. If displayed as crosses or spheres, the radius can be set by the value of a variable at that node. To set attributes using the Node, Element, and Line Attributes section:

1. Select **Edit > Part Feature Detail Editors > part type**.

2. In the parts list at the top of the Feature Detail Editor dialog, select the desired part(s).

By default, any changes you make to attributes will take effect immediately. If you wish to "batch" a series of changes, select **Edit > Immediate Modification** (be sure to use the Edit menu in the Feature Detail Editor dialog) to toggle this setting off. When toggled off, a button at the bottom of the dialog becomes active: **Apply Changes**. Click it when you are ready to apply a set of changes.

3. Set the desired attribute(s):

Set visibility of nodes, lines, elements

Set **node/element label** visibility

Set Line width and Style (Solid, Dotted, or Dot-dashed)

Set **element representation** (described below)

Set element shrink factor (shrink elements toward the centroid)

Set angle for Feature Angle representation

Set variable to use for failed element removal.

Set the values and rules for failed element variable values

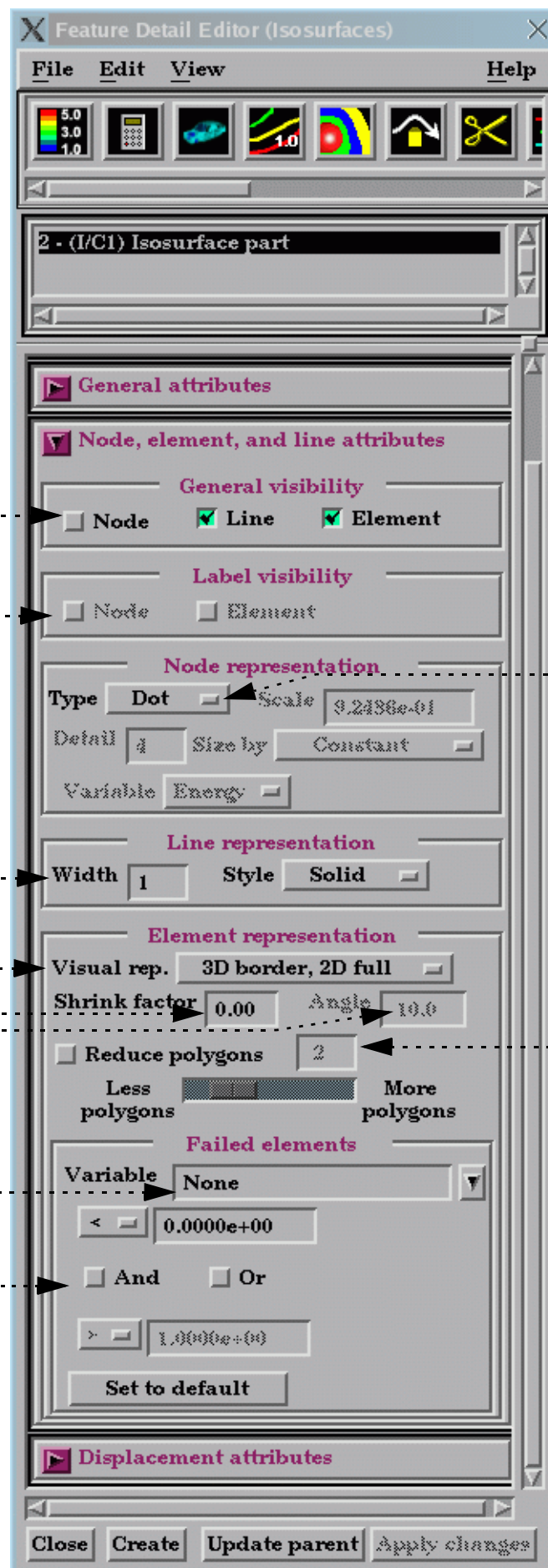

Set node representation

- Dot: nodes are displayed as points.

- Cross: nodes are displayed as crosses and can be fixed size (size set by the Scale value) or sized based on a variable (and scaled by the Scale value).

- Sphere: nodes are displayed as spheres and can be fixed size (size set by the Scale value) or sized based on a variable (and scaled by the Scale value). Sphere detail controlled by Detail value.

Set polygon reduction. Same model, but simpler representation. Trade-off of visual fidelity and rendering speed.



EnSight provides five representation modes (and three combination modes) for parts (see also [How To Change Visual Representation](#)):

<i>Full</i>	Every face and edge of every element is displayed.
<i>Border</i>	Only unshared faces (for 3D parts) or unshared edges (for 2D parts) are displayed.
<i>3D Border, 2D Full</i>	Display 3D parts in Border representation; display 2D parts in Full representation. This is the default representation for all parts.
<i>3D Feature, 2D Full</i>	Display 3D parts in Feature representation; display 2D parts in Full representation.
<i>3D nonvisual, 2D Full</i>	Display 3D parts in Non Visual representation; display 2D parts in Full representation.
<i>Feature Angle</i>	Only those edges joining faces in the Border representation for which the angle between the faces is less than some threshold are displayed. Feature Angle typically extracts the topological features of interest in a model.
<i>Non Visual</i>	No visual representation exists on the client. It is often useful to use Non Visual as the representation for 3D computational domain parts – provided you also have some sort of shell part to display the outer surface.
<i>Bounding Box</i>	Displays a bounding box surrounding (and in place of) the nodes and elements.

Displacement Attributes

In structural mechanics simulations, a common output variable is a set of vectors representing the movement or displacement of geometry. Each displacement vector specifies a translation of a node from its original position (an offset). EnSight can display and animate these displacements to help visualize the relative motion of geometry. To set Displacement attributes (see also [How To Display Displacements](#)):



Set Displace By to either None (no displacement) or the vector variable to use for displacement.

Set nodal displacement factor to reduce or exaggerate a displacement

IJK Axis Display Attributes

Model Parts and clips (because they can be structured parts) will have these attributes available. These attributes will only be applicable to structured parts.

Toggle IJK Axis Visible to display an IJK axis for the part:

The scale factor for the IJK Axis triad can be modified in this field.....



SEE ALSO

[Introduction to Part Creation](#)

User Manual: [Part Attributes](#)





Display Labels

INTRODUCTION

It is often useful to be able to identify specific nodes or elements within your model. EnSight can display node and element labels in the Graphics Window. If your data provides explicit node or element labels (or you are using EnSight data formats and have asked EnSight to assign ids), EnSight will be able to display those values. Only model parts can have labels.

Displaying labels on parts with thousands of nodes or elements can obscure both the geometry as well as the labels of interest (as well as degrading display performance). EnSight provides a filtering mechanism to display only selected ranges of labels.

BASIC OPERATION

Displaying Node and/or Element Labels

To display labels (and to control filtering and coloring):

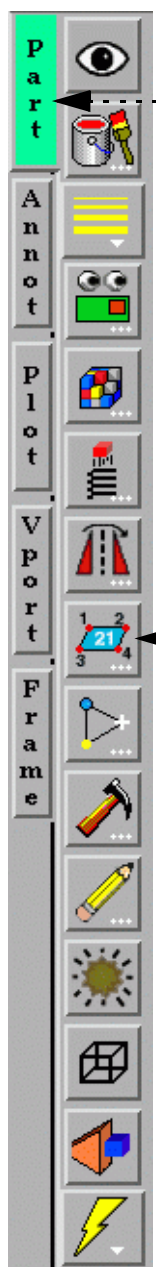

1. Select the desired part(s) in the Main Parts list.
2. Select Part mode in the Mode Selection area.
3. Click the Node/Element Label icon to display the Node/Element labeling attributes dialog.
4. Click the appropriate toggle(s) to turn on/off node and/or element labels.
5. To set filters for node/element labels, select the desired filter and enter the appropriate values in the Low and/or High fields.
6. Set the node/element label color.

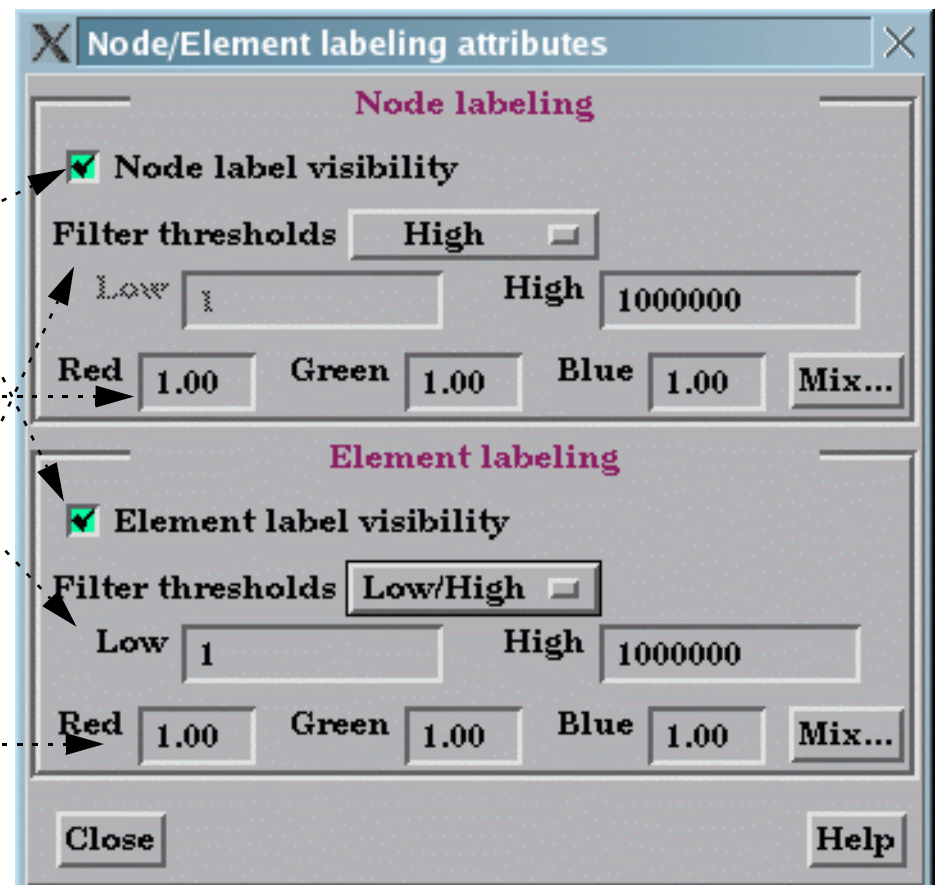

The label filters operate as follows:

None	Display all labels.
Low	Remove all labels < the Low value
Band	Remove all labels \geq Low and \leq High
High	Remove all labels > the High value
Low/High	Remove all labels < the Low value as well as those > the High value.



Note that the Node and Element Label toggles also have counterpart toggles in the View Menu. These act as global toggles that enable or disable any per-part node or element labels:

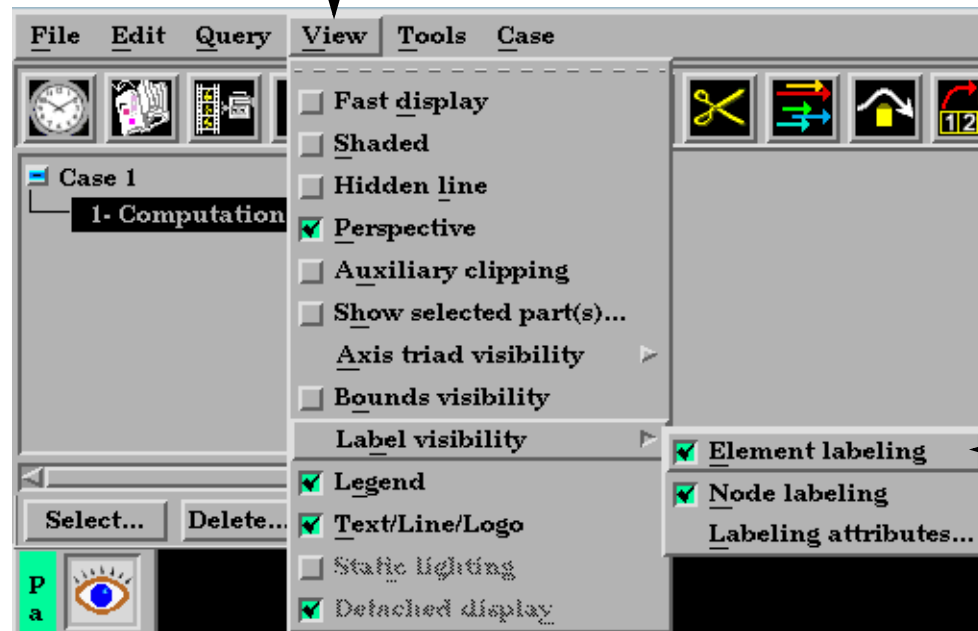

OTHER NOTES

Note that created parts do not have node or element labels.

Another useful technique for reducing label clutter is to use the front and back Z clipping planes to display only a thin slice of interest. See [How To Set Z Clipping](#) for more information.

SEE ALSO

User Manual: [Label Visibility](#)



Set Transparency

INTRODUCTION

EnSight can display parts as transparent using two different methods:

True (alpha) True transparency uses the hardware alpha planes. Although the resulting visual effect is superior to fill patterns, true transparency is much slower to draw (especially for large models) since all geometry must be sorted from back to front prior to *each* redraw.

Fill Pattern Fill pattern or screen-door transparency uses polygon fill patterns to control where polygons are drawn (typically a fine grid specifying on and off). EnSight provides three patterns that yield varying degrees of pseudo-transparency.

Transparency is not available on all platforms.

Note: Hidden line overlays cannot be displayed while using transparency

BASIC OPERATION

1. Select the desired part(s) in the Parts List.
2. Select Part in the Mode Selection area to enter Part mode.

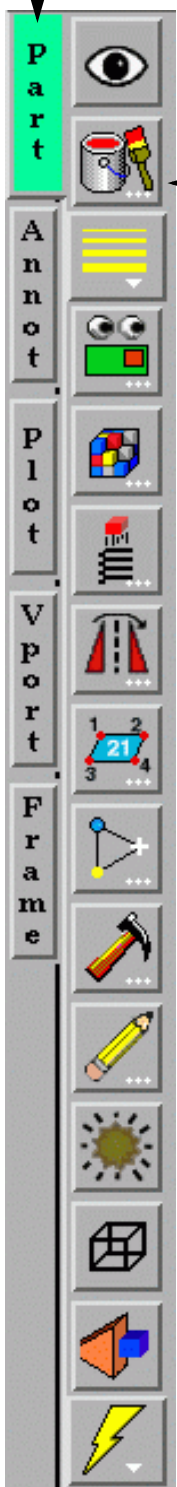

3. Click the Part color, lighting, & transparency icon to open corresponding dialog.

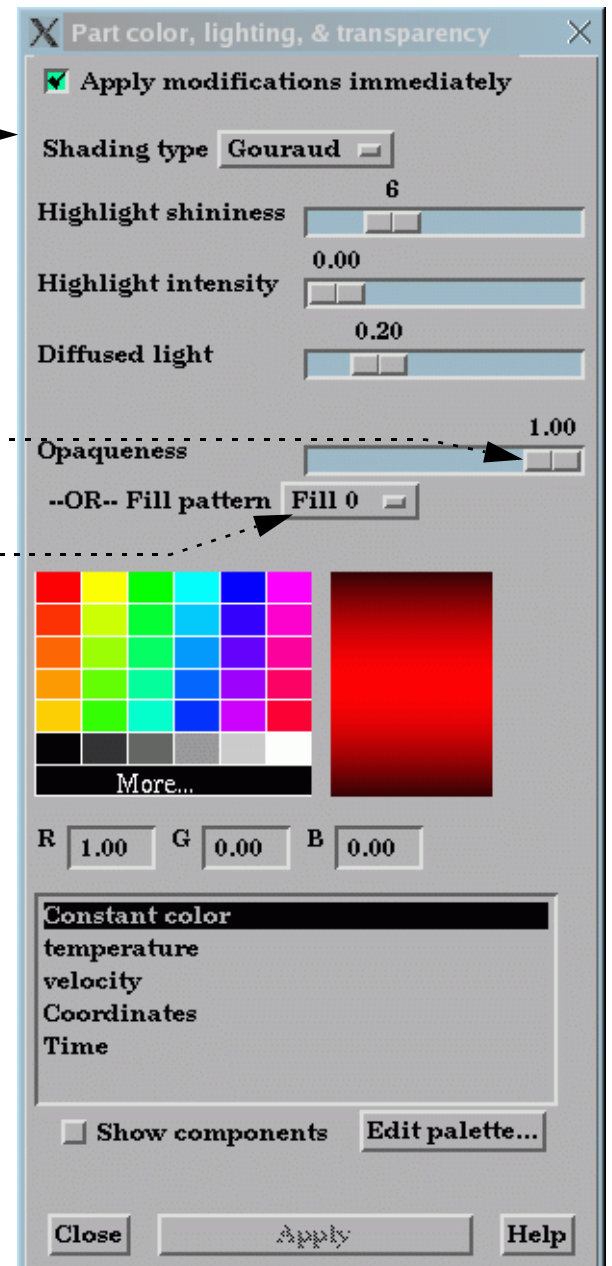

For true transparency:

4. Adjust the slider to the desired setting.

The Graphics Window will dynamically update as the slider is adjusted.

OR

For Fill Pattern transparency:

4. Select the desired pattern from the Fill Pattern pulldown.

Fill pattern 0 is solid.

SEE ALSO

User Manual: [Part Transparency](#)



Select Parts

INTRODUCTION

Manipulating parts is one of the fundamental operations in EnSight. Before you operate on parts, they must be selected in the Main Parts list. Parts can either be selected through standard mouse interaction with the items in the Main Parts list or selected by picking parts in the Graphics window.

BASIC OPERATION

Selecting Parts using the Main Parts List

Items in the Parts List itself are selected using standard Motif methods:

To ...	Do this ...	Details ...
Select an item	Select (or single-click)	Place the mouse pointer over the item and click the left mouse button. The item is highlighted to reflect the “selected” state.
Extend a contiguous selection	Select-drag	Place the mouse pointer over the first item. Click and hold the left mouse button as you drag over the remaining items to be selected. Only contiguous items may be selected in this fashion.
Extend a (possibly long) contiguous selection	Shift-click	Select the first item. Place the mouse pointer over the last item in the list to be selected. Press the shift key and click the left mouse button. This action will extend a selection to include all those items sequentially listed between the first selection and this one.
Extend a non-contiguous selection	Control-click	Place the mouse pointer over the item. Press the control key and click the left mouse button. This action will extend a selection by adding the new item, but not those in-between any previously selected items.
De-select an item	Control-click	Place the mouse pointer over the selected item. Press the control key and click the left mouse button. This action will de-select the item.
Open the Quick Interaction Area for a part	Double-click	Place the mouse pointer over the item and click the left mouse button twice in rapid succession.

Selecting Parts using the Select... Options

There are several other useful options for selecting parts:

1. Click the **Select...** button just below the main parts list.

2. Select the desired option.

All	Selects all parts in the list.
Invert	Inverts the selection. Namely, all parts currently selected become unselected and all unselected become selected.
Invisible	Selects all visible parts.
Visible	Selects all invisible parts
Region	Selects all parts that are within the selection tool. (Requires that the selection tool be on)
Showing	Selects all visible parts which are showing in the graphics window.
Keyword...	Opens a dialog which allows for selections using keywords and regular expressions.
Unselect	Unselects all parts in the list.

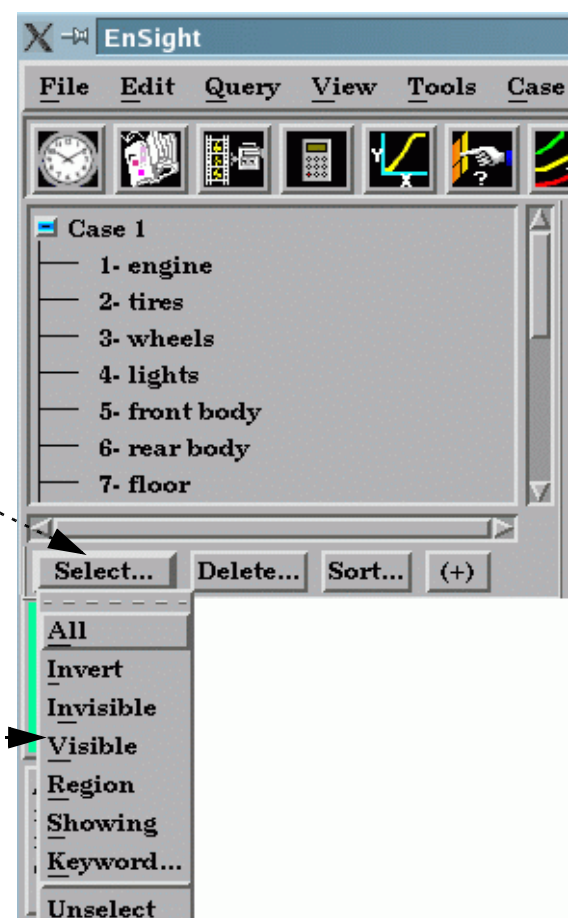



Selecting Parts by Picking

Parts can also be selected by “picking” them in the Graphics window. To select parts by picking:

1. From the Pick pulldown icon, select Pick Part.
(Note that this is the default, and this setting will be retained until explicitly changed.)
2. Position the mouse pointer over the desired part in the Graphics Window and press the ‘p’ key (or perform the mouse action which has been set to “Selected pick action” in Edit > Preferences > Mouse and Keyboard).
See below regarding how parts are identified.

Note that the picked part is now selected in the Main Parts list.

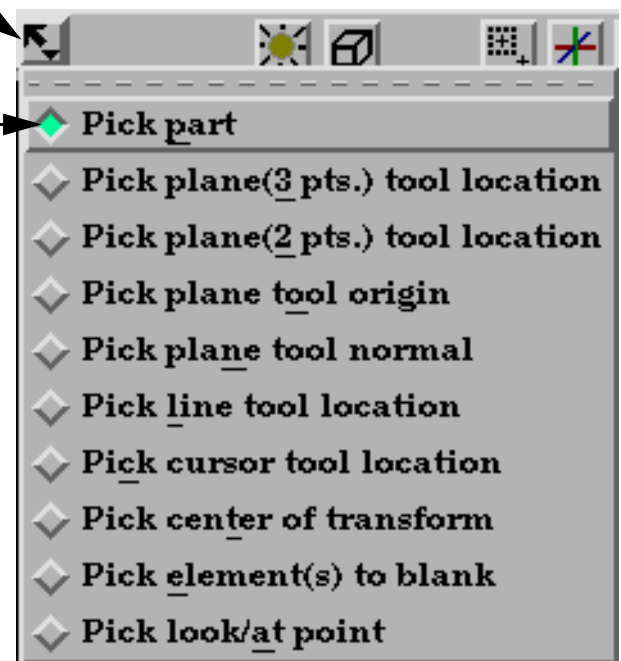

Parts are identified for picking as follows. If the part (as represented on the client) consists of surface (2D) elements, a pick will occur if the mouse cursor is over any portion of the surface – even if the part is drawn in line mode and the mouse was over the middle of the element (and not over one of the visible lines). If the part is drawn as 1D elements (e.g. the part is in feature angle representation), the mouse must be over one of the visible lines of the part.

By default, when you press the ‘p’ key any previously selected parts are de-selected. Holding down the Control key as you hit ‘p’ modifies this behavior: if the picked part is not currently selected, it will be *added* to the existing selection (so you can select multiple parts by picking), otherwise the picked part is de-selected.

OTHER NOTES

Selecting View > Show Selected Parts will open a small graphics window that will only display the parts currently selected in the Main Parts list. This can be helpful when trying to select multiple parts from a large list.

SEE ALSO

User Manual: [“Part Selection and Identification”](#)



INTRODUCTION

In many instances, a modeler can take advantage of symmetry present in a problem to reduce the computational complexity of a subsequent analysis. EnSight can impart visual realism to such models by mirroring parts around any or all axes of the part's reference frame or performing rotational symmetry about any of the axes. Although the mirrored or rotated portions appear identical to the source part (except for the reflection or rotation), they are only visual (client-based) and cannot be used for calculation. For example, you cannot start a particle trace in one half and expect the trace to cross the plane of symmetry into the other half (although you can make the particle trace part symmetric as well).

EnSight also provides "true" or "computational" symmetry operations (mirror, rotational, translational) as an attribute of the part's reference frame. With computational symmetry, you can trace particles across a periodic boundary.

Both types of symmetry (visual or computational) are based on the part's reference frame. Although you can use simple visual or computational symmetry without having to manipulate the frame, more advanced usage of symmetry could require a working knowledge of frames. See [How To Create and Manipulate Frames](#) for more information.

BASIC OPERATION

Visual Symmetry

Visual symmetry is an attribute of parts. You can enable display of a mirrored copy of a part into one or more of the seven octants (opposite of +,+,+) of the part's reference frame. You can also enable display of a number of rotational instances about the x,y, or z axes of the part's reference frame. To display visual symmetry:

1. Select the desired part(s) in the Main Parts list.
2. Click Part in the Mode Selection area to enter Part mode.
3. Click the Visual Symmetry icon.

Visual Mirror Symmetry:

4. Select Mirror from the Type pulldown menu.
5. Select the desired octant(s) from the menu.

Visual Rotational Symmetry:

4. Select Rotational from the Type pulldown menu.
5. Select rotational axis, instance angle, and number of instances.

Recall that symmetry is performed with respect to the reference frame of the part. The frame's axes define the partitioning of space into the octants that attached parts are mirrored into, or the rotational axis. If the symmetry operation did not produce the desired effect, it is probably due to the fact that the part's frame is not aligned with the plane of symmetry, or the rotational symmetry axis, as designed for the model. The solution is to create a new frame, assign the part(s) to the new frame, and position the frame such that two of its axes lie in the plane of symmetry, or one of its axes align with the rotational axis. These operations are discussed in [How To Create and Manipulate Frames](#).



Computational Symmetry

Computational symmetry can be used for unstructured and structured *model* parts with periodic boundary conditions. (*Note, it does not work for created parts.*) Computational symmetry can handle rotational, translational, and mirror symmetry. Unlike visual symmetry, computational symmetry actually produces the symmetric geometry and variables on the server - allowing for more than just visual symmetry.

You enable computational symmetry by selecting the frame, specifying the type (Mirror, Translational, Rotational), and setting type specific attributes (such as the rotation angle and the number of instances to create). Each part assigned to the frame will be updated on the server to reflect the specified symmetry.

Note that each new instance of a part created through computational symmetry creates a new part on the server.

To use computational symmetry, you will need to enable Frame Mode if it isn't already enabled. (Edit > Preferences... General User Interface - Frame Mode Allowed). Then:

1. Click **Frame** in the **Mode Selection** area to enter **Frame** mode.
2. If the default frame (frame 0) is not correctly positioned for the desired symmetry operation, create a new frame, position the frame in the proper location and orientation, and assign the part(s) to the new frame. (See [How To Create and Manipulate Frames](#) for details.)
3. Select the desired frame.
4. Click the **Computational Symmetry Attributes** Icon.

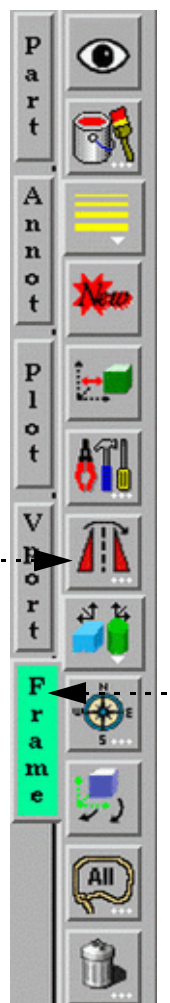

The remaining steps depend on the type of symmetry desired.

Mirror Symmetry is similar to graphical symmetry as described above.

5. Select **Mirror** from the **Type** pulldown.
6. Select the desired octant(s) from the **Mirror In** pulldown.
7. Click **Update**.

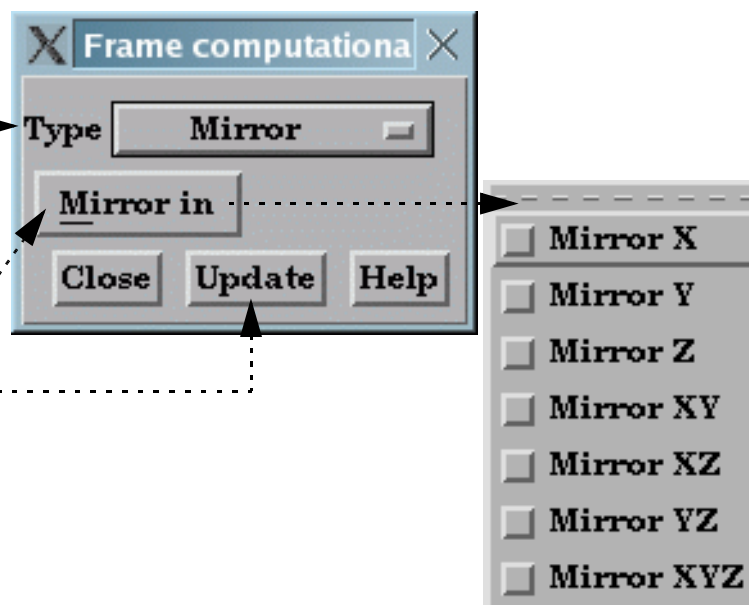

Rotational Symmetry creates instances by rotating, around the selected axis of the frame, the specified number of degrees. The selected frame's axis must be aligned with the desired symmetry axis.

5. Select **Rotational** from the **Type** pulldown.
6. Select the frame rotational axis.
7. Set the desired rotation angle (in degrees) in the **Angle** field.
8. Set the desired number of instances in the **Instances** field (number 1 is the original, set Instances to 2 to yield one copy).
9. If a periodic match file is available, toggle **Use Periodic File** and enter the file name.

Periodic match files are discussed below.

10. Click **Update**.

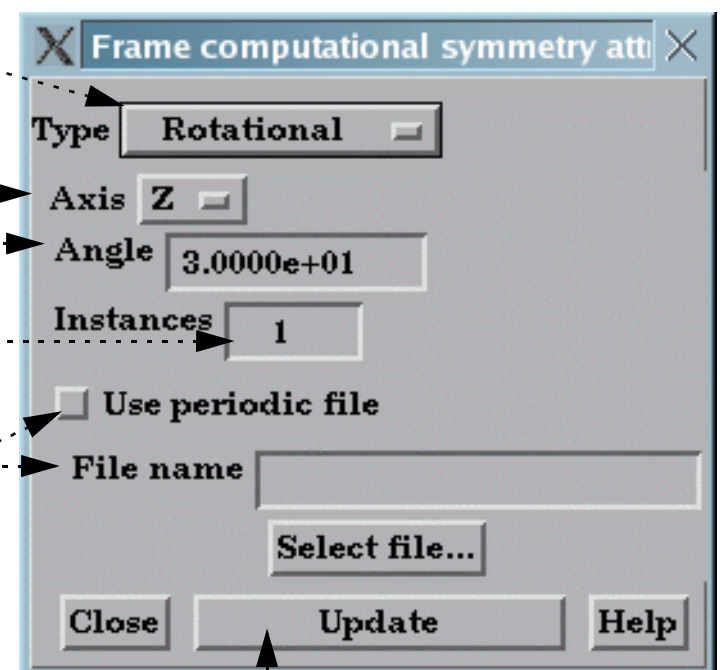



Translational Symmetry creates instances in the direction of the specified translation vector. The translation vector is first rotated by the frame's rotation, but is independent of the frame's origin location.

5. Select Translational from the Type pulldown.

6. Enter the desired translation vector in the XYZ fields and press return.

7. Set the desired number of instances in the Instances field (number 1 is the original, set Instances to 2 to yield one copy).

8. If a periodic match file is available, toggle Use Periodic File and enter the file name.

Periodic match files are discussed below.

9. Click Update.

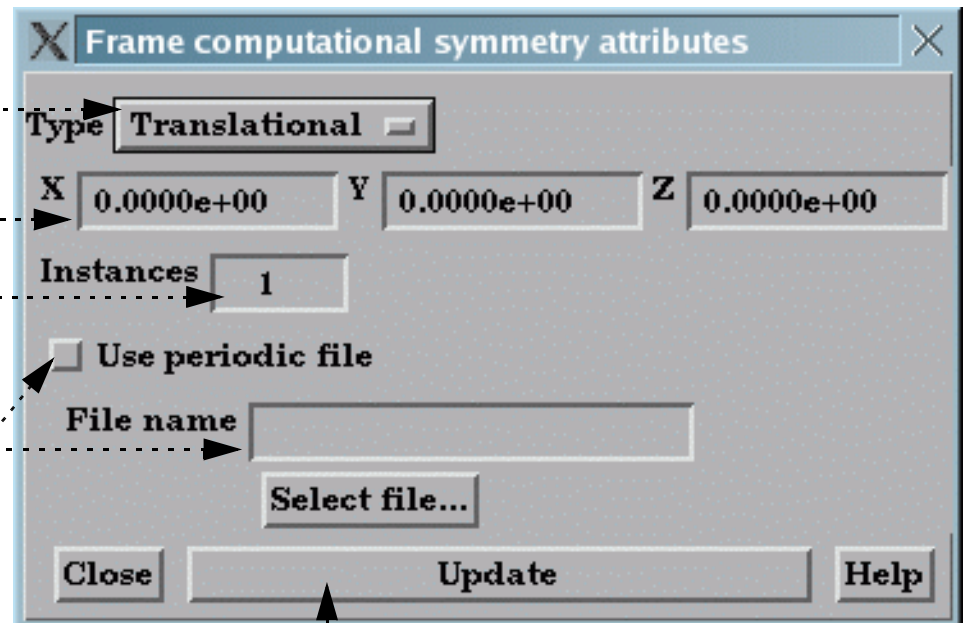

Periodic Matching for Computational Symmetry

When a model is created with periodic boundary conditions, there is typically a built-in correspondence or “match” between certain nodes and elements. For example:

The elements defined by nodes 1,2,3 and nodes 1,6,7 should match when rotated about an axis passing through node 1 (perpendicular to the screen). When another instance is created, node 2 matches with 6 and node 3 matches with 7.

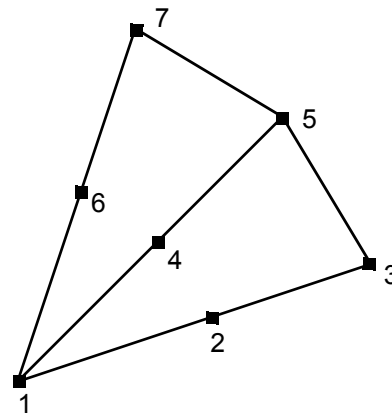

When instances are added to a part, it is desirable to eliminate these duplicate nodes. Without a match file, EnSight will attempt to find and remove them using a hashing scheme. This method works quite well, but may not find all duplicates. (Remaining duplicates are usually noticed when the part is in feature angle representation since EnSight treats elements with duplicate nodes as separate – even if they are coincident.)

Note that if you have a periodic match file you do not need to specify the rotation axis and angle in the Frame Computational Symmetry Attributes dialog – the value is provided in the file.

A user-supplied matching file can be used to quickly find and remove all duplicates. The match file is a simple ASCII text file. The file for the example above would be (the text in italics is not part of the file):

```
rotate_z           specifies rotational symmetry and the applicable axis
52.34             the angle of rotation (in degrees)
3                 the number of node pairs to follow
1 1               first node pair
2 6               second node pair ...
3 7
```

See [Periodic Match File](#) for more information on periodic match files.

SEE ALSO

[How To Create and Manipulate Frames](#)



Animate
Animate Transient Data

INTRODUCTION

Transient data can be animated through EnSight's flipbook capability. During the flipbook load process, all parts (both model and created) are automatically rebuilt (if necessary) using the data from each time step in sequence. At each step, a graphical "page" is created and stored in memory. When the flipbook is active, the pages are displayed in order as rapidly as the hardware allows (although you can slow it down). You can also step through pages manually.

The graphical pages can be one of two types: *object* or *image*. An object flipbook saves each page as 3D geometry so you can continue to manipulate the model (e.g. rotate or zoom) during playback. However, for very large models and/or long sequences, the memory requirements can be substantial. In this case, you can create image flipbooks that save only the image pixels for each page. Although the size of each page is now fixed, you cannot change the viewing parameters without reloading the flipbook.

This article covers using the flipbook capability for transient data (and assumes that you have successfully loaded your transient data). See [How To Create a Flipbook Animation](#) for more details on flipbooks. EnSight's keyframe animation capability also works with transient data and provides a flexible mechanism for synchronizing your available time steps with the output animation frames. See [How To Create a Keyframe Animation](#) for more information.

BASIC OPERATION

Prior to loading the flipbook, you should create all parts of interest (e.g. clips, contours, isosurfaces, etc.). These parts will automatically be recalculated for each time step. To load a transient flipbook:

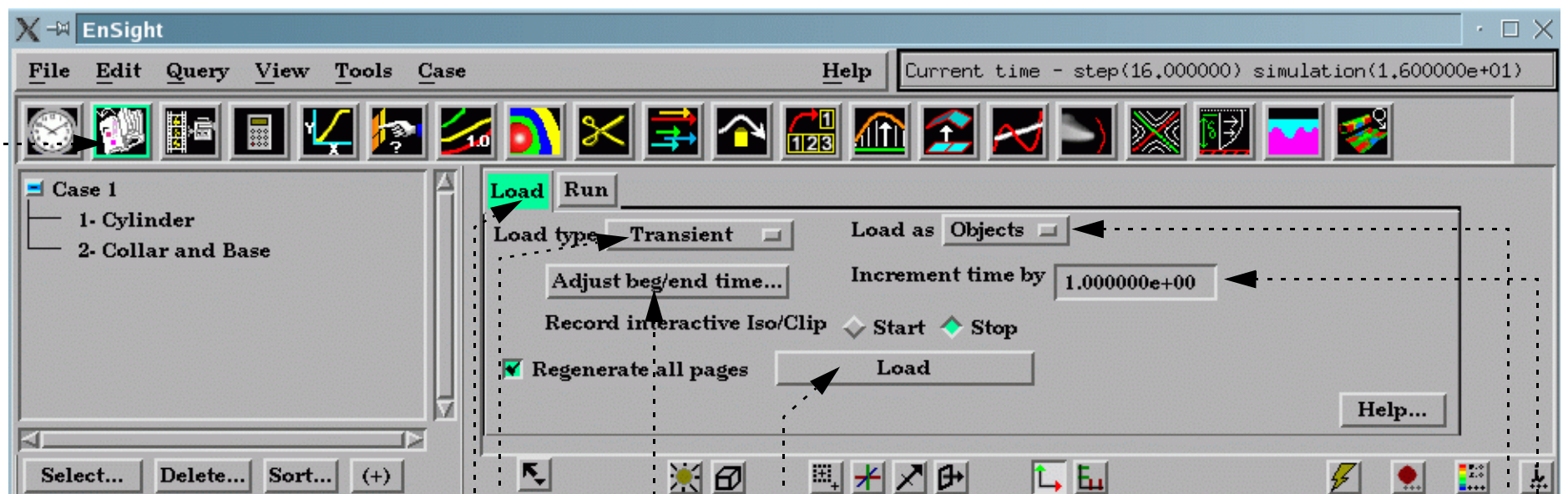

1. Click the Flipbook Animation icon in the Feature Icon Bar.

2. Be sure that the Load tab is selected.

3. Be sure the Load Type is set to Transient.

7. Click Load.

4. Select the desired page type (Object or Image).

5. If desired, reset the current beginning and ending time.

(Clicking this button will replace the Flipbook Quick Interaction area with the [Solution Time Quick Interaction](#) area. When you are done, click the Flipbook animation... button to return).

6. If desired, you can specify a time increment for the load.

For example, using 0.5 would create pages representing time steps 0, 0.5, 1, 1.5, 2, 2.5, etc. The in-between steps are calculated by linear interpolation.



The Load Flipbook Status dialog will open and show the progress of the load. You can cancel the load by clicking the Cancel button and retain all the pages loaded to that point. Once the load is complete, you can run the flipbook using VCR type controls:

After a flipbook load, the next 3 steps will generally be the default already.

1. Make sure the Run tab is selected.
2. Make sure the Display is set to flipbook pages.
3. Click the run forward or backward button.

The flipbook will begin to run.

OR

You can also step through the pages manually:

3. Click the forward/backward single step buttons (once for each page).

You can also enter values in the Current Page field (and press return) to jump to a specific page.

4. To change the range of displayed pages, enter new values in the Begin Page and/or End Page fields (and press return) or click and drag the left/right slider handles.
5. To change the display speed, enter a new value in the Display Speed field (and press return) or simply slide the slider.

A speed of 1.00 represents "full" hardware speed with no delays; a value of 0.5 is half of full speed.

6. To cycle the page display, click Cycle.

Cycle will replay the pages in reverse order when the last page is reached.

7. To stop the animation, click the stop button.

8. When done, set the Display to "original model" instead of "flipbook pages".

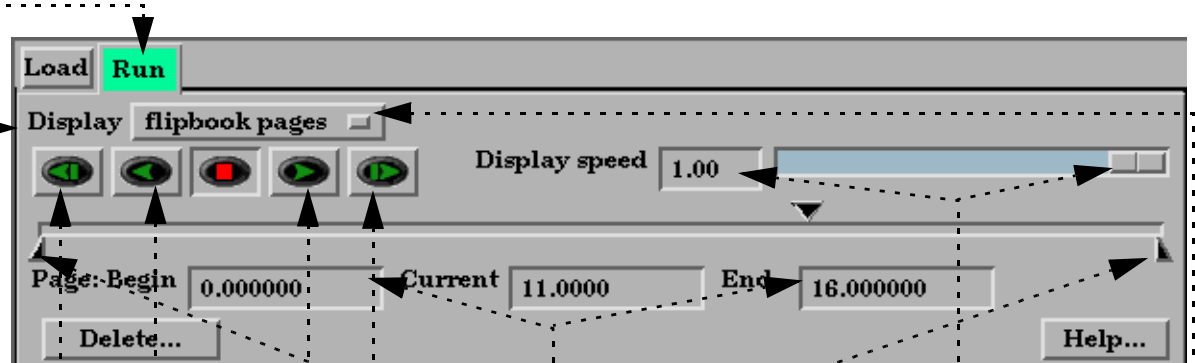



Record

Once a flipbook is playing, it can be recorded.

The “Record current graphics window animation” icon will be on.

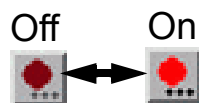

Click it to open the Save Animation dialog.

Set the recording format, and the window size under the Record and Advanced tabs.

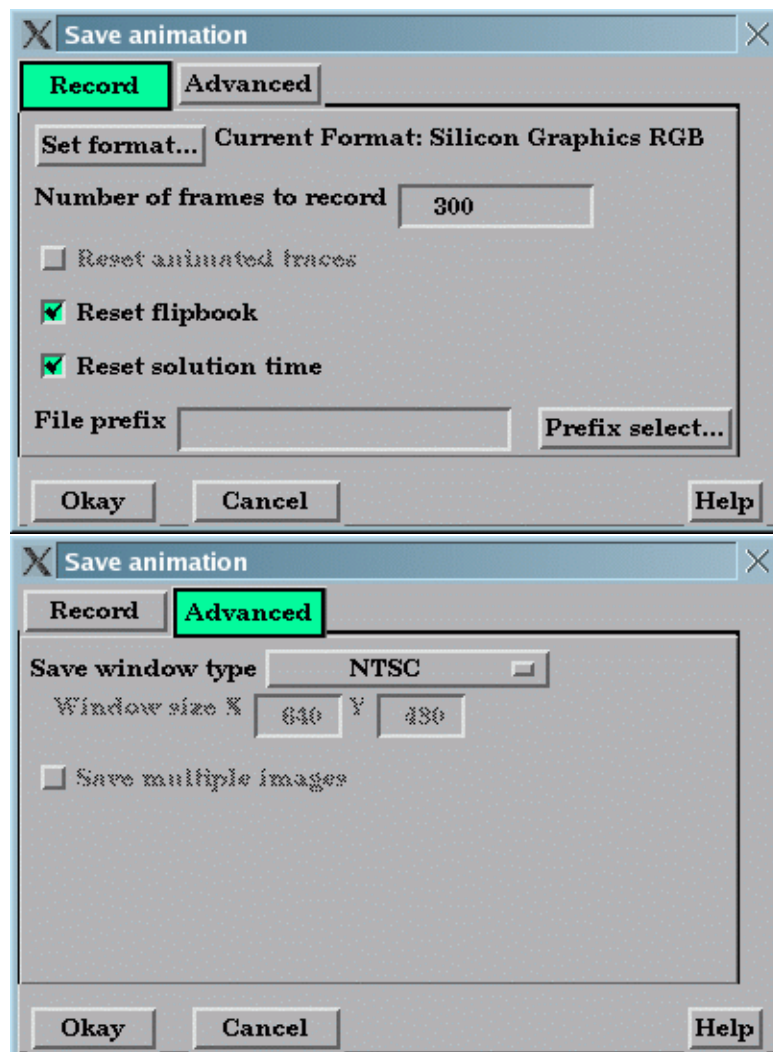

Available recording file formats:

Apple PICT	Flipbook files saved as sequence of Apple PICT files.
JPEG	Flipbook files saved as sequence of JPEG files.
TIFF	Flipbook files saved as sequence of TIFF files.
PCL	Flipbook files saved as sequence of Page Control Language files.
PostScript	Flipbook files saved as sequence of PostScript files.
Silicon Graphics RGB	Flipbook files saved as sequence of SGI RGB files.
TARGA	Flipbook files saved as sequence of TARGA files.
CEI RGB with depth	Flipbook files saved as sequence of RGB files with depth.
EnVideo	Flipbook files are saved to EnVideo file.
MPEG1 / MPEG2	Flipbook files are saved to an MPEG file.
AVI	Flipbook files are saved to an AVI file.

Delete

Any type of flipbook can be deleted:

1. Click **Delete...** in the **Flipbook Quick Interaction Editor**.
2. **Confirm the deletion.**

All memory associated with the flipbook is freed.

ADVANCED USAGE

If you have created transient particle traces (pathlines) and set up a particle trace animation, you can also load a flipbook and show the particle trace animation synchronized with the flipbook. The trace animation will automatically play through the time range of the flipbook and stay in sync with the flipbook pages. See [How To Create Particle Traces](#) and [How To Animate Particle Traces](#) for more information.



OTHER NOTES

Since both object and image flipbooks build pages from the current set of parts based on their current attributes, if you make a change (such as color a part by a different variable or create a new part), you must reload the flipbook. There are exceptions. With an object flipbook, you can make a part invisible while the flipbook is running.

SEE ALSO

[How To Load Transient Data](#)

[How To Create a Flipbook Animation](#)

User Manual: [Flipbook Animation](#), [Flipbook Animation](#)





INTRODUCTION

Various types of data can be animated through EnSight's flipbook capability. During the flipbook load process, selected parts are automatically rebuilt based on some criteria (such as a delta for a clipping plane). For each step, a graphical "page" is created and stored in memory. When the flipbook is active, the pages are displayed in order as rapidly as the hardware allows (although you can slow it down). You can also step through pages manually.

The graphical pages can be one of two types: *object* or *image*. An object flipbook saves each page as 3D geometry so you can continue to manipulate the model (e.g. rotate or zoom) during playback. However, for very large models and/or long sequences, the memory requirements can be substantial. In this case, you can create image flipbooks that save only the image pixels for each page. Although the size of each page is now fixed, you cannot change the viewing parameters without reloading the flipbook.

There are four distinct types of flipbooks:

Transient	Pages are constructed by stepping from the current beginning to ending time range and rebuilding all time-dependent parts based on each time step in sequence.
Mode Shapes	Pages are constructed by applying a cosine-driven scaling factor to a displacement variable.
Create Data	Pages are constructed by applying a delta to either a clip part or an isosurface.
Linear Load	Pages are constructed by applying linear interpolation ranging from zero to the maximum (displacement) vector field value.

This article covers only the "Create Data" type of flipbook. See [How To Animate Transient Data](#) for details on transient flipbooks. See [How To Display Displacements](#) for details on mode shape flipbooks.

For more sophisticated animations, use EnSight's [keyframe animation](#) capability.

BASIC OPERATION

For each page of the flipbook, a delta value will be applied to all active clip parts and isosurfaces. For clips, the delta represents a translation vector; for isosurfaces it is an increment to the isovalue. There are two ways to specify these delta values: either through interactive manipulation or via the applicable Feature Detail Editor for the part. The former method is discussed below, the latter in the [Other Notes](#) section at the end.

Prior to loading the flipbook, you should create all parts that you wish to animate ([clips](#) and/or [isosurfaces](#)) and

manipulate the part so that it is in the desired location for the start of the flipbook. To load the flipbook:

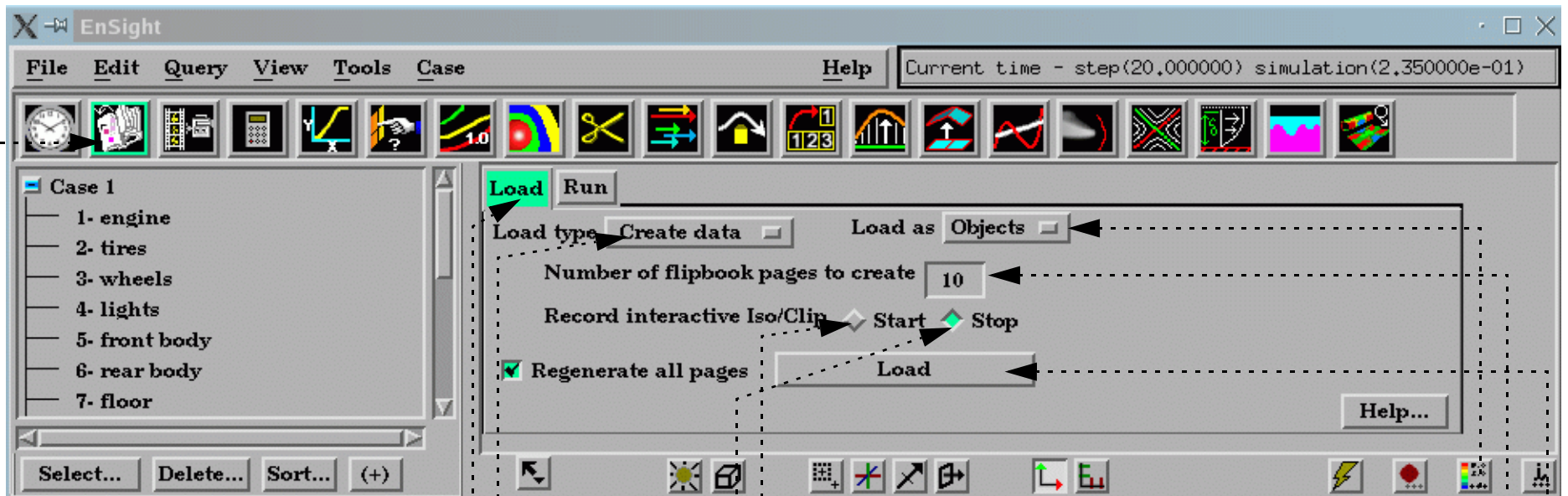

1. Click the Flipbook Animation icon in the Feature Icon Bar.

2. Be sure that the Load tab is selected.

3. Be sure the Load Type is set to Create data.

4. Select the desired page type (Object or Image).

5. Set the desired number of pages.

The delta value will be added to the appropriate entities for each page

6. Click Start to begin recording interactive part manipulations.

6a. For clipping plane parts, reopen the Quick Interaction area for the part (double-click on the part in the Main Parts list).

6b. Toggle on Interactive Tool, move the mouse into the Graphics Window and interactively position the tool to the desired location for the end of the flipbook.

6a. For isosurface parts, reopen the Quick Interaction area for the part (double-click on the part in the Main Parts list).

6b. Change the Interactive Pulldown to Manual and adjust the slider until the isovalue is as desired for the end of the flipbook.

7. Return to the Flipbook Quick Interaction area (*i.e.* perform step 1 again).

8. Click Stop to end recording interactive Iso/Clip.

9. Click Load.



The Load Flipbook Status dialog will open and show the progress of the load. You can cancel the load by clicking the Cancel button and retain all the pages loaded to that point. Once the load is complete, you can run the flipbook using VCR type controls:

After a flipbook load, the next 3 steps will generally be the default already.

1. Make sure the Run tab is selected.
2. Make sure the Display is set to flipbook pages.
3. Click the run forward or backward button.

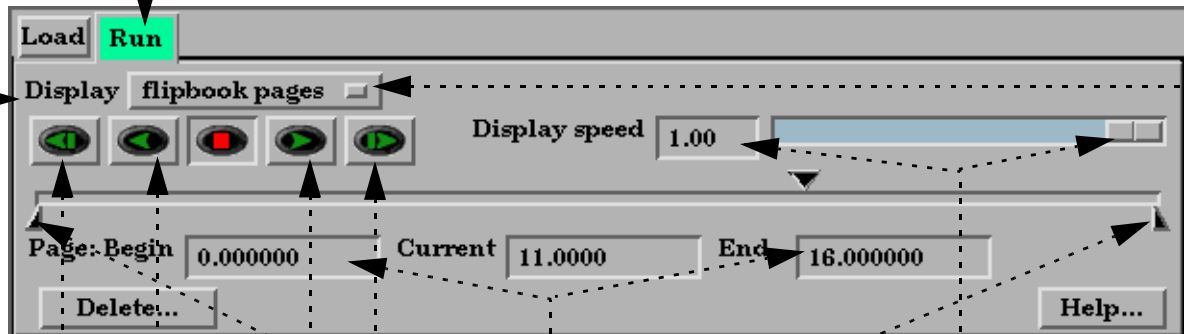

The flipbook will begin to run.

OR

You can also step through the pages manually:

3. Click the forward/backward single step buttons (once for each page).

You can also enter values in the Current Page field (and press return) to jump to a specific page.

4. To change the range of displayed pages, enter new values in the Begin Page and/or End Page fields (and press return) or move the slider range markers.
5. To change the display speed, enter a new value in the Display Speed field (and press return) or simply slide the slider.

A speed of 1.00 represents "full" hardware speed with no delays; a value of 0.5 is half of full speed.

6. To cycle the page display, click Cycle.

Cycle will replay the pages in reverse order when the last page is reached.



7. To stop the animation, click the stop button.
8. When done, set the Display to "original model" instead of "flipbook pages".



Record...

Once a flipbook is playing, it can be recorded.

The “Record current graphics window animation” icon will be on.

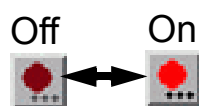

Click it to open the Save Animation dialog.

Set the recording format, and the window size under the Record and Advanced tabs.

Note: This same kind of recording can also be done for:

1. Streaming transient data from disk in the Solution Time dialog.
2. Animated particle traces.
3. Spin Mode using the F4 key.
4. Isosurface auto cycle.
5. Clip auto cycle.

Simply start the animation and click on the Record Animation icon when it is bright red.

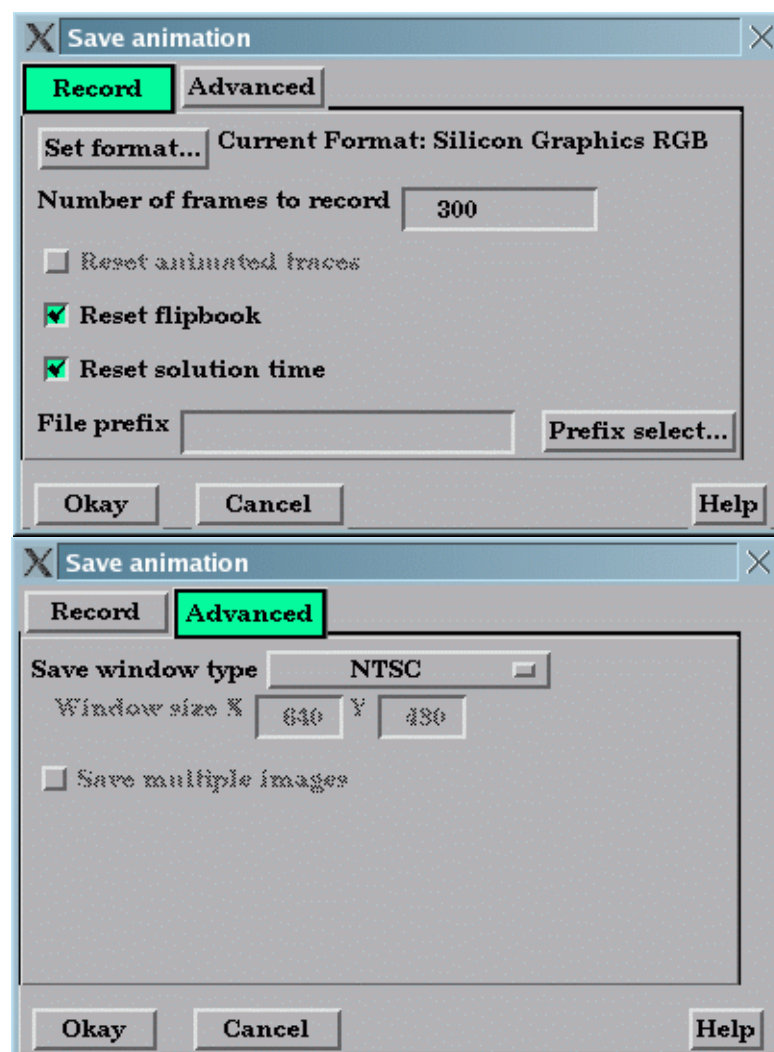

Available recording file formats:

Apple PICT	Flipbook files saved as sequence of Apple PICT files.
JPEG	Flipbook files saved as sequence of JPEG files.
TIFF	Flipbook files saved as sequence of TIFF files.
PCL	Flipbook files saved as sequence of Page Control Language files.
PostScript	Flipbook files saved as sequence of PostScript files.
Silicon Graphics RGB	Flipbook files saved as sequence of SGI RGB files.
TARGA	Flipbook files saved as sequence of TARGA files.
CEI RGB with depth	Flipbook files saved as sequence of RGB files with depth.
EnVideo	Flipbook files are saved to EnVideo file.
MPEG1 / MPEG2	Flipbook files are saved to an MPEG file.
AVI	Flipbook files are saved to an AVI file.

Delete

Any type of flipbook can be deleted:

1. Click **Delete...** in the **Flipbook Quick Interaction Editor**.
2. **Confirm the deletion.**

All memory associated with the flipbook is freed.



OTHER NOTES

Rather than specify the part delta values through interactive part manipulation as described above, you can set the values explicitly using the Feature Detail Editor for the part. For clip parts:

1. Select **Edit > Part Feature Detail Editors > Clips...** to open **Feature Detail Editor (Clips)**.
2. Select the desired part in the parts list of the **Feature Detail Editor (Clips)**.
3. In the **Animation Delta** section, enter the desired values in the X, Y, and Z fields and press return.

For isosurfaces:

1. Select **Edit > Part Feature Detail Editors > Isosurfaces...** to open **Feature Detail Editor (Isosurfaces)**.
2. Select the desired part in the parts list of the **Feature Detail Editor (Isosurfaces)**.
3. In the **Animation Delta** field, enter the desired isovalue delta value and press return.

When a flipbook is subsequently loaded, active clips and/or isosurfaces will update based on these animation delta values.

Since both object and image flipbooks build pages from the current set of parts based on their current attributes, if you make a change (such as color a part by a different variable or create a new part), you must reload the flipbook. There are exceptions. With an object flipbook, you can make a part invisible while the flipbook is running.

SEE ALSO

User Manual: [“Flipbook Animation” on page 6](#)



INTRODUCTION

EnSight's ability to handle large, transient datasets has led to its use in the production of many video animations of engineering and scientific data. EnSight uses a *keyframe animation* system. A keyframe is a set of viewing parameters that specify a particular view of the scene in the Graphics Window. The view may be notable because of what is visible, or because the view represents the transition point from one scene to another. Once a set of keyframes has been selected, EnSight can automatically generate frames to interpolate the viewing parameters between keyframes for a smooth animation.

The changes to viewing parameters between keyframes are not limited to simple rotations, translations, or zoom operations. You can also use EnSight's **frames** capability to move parts independently, e.g. to animate an exploded view of a complex assembly. You can also animate the **global look-from and look-at points** for "fly-by" style animations.

While refining your animation, you can display it directly in the Graphics Window. When complete, you can specify the output resolution (e.g. for NTSC or PAL video) and set the recording device (e.g. to a disk file).

Although the production of adequate animation is easy, good animation takes experience. A sequence that looks good on your high resolution workstation screen may look less than acceptable when transferred to VHS videotape. An object rotating in ten degree increments may be an appropriate speed for your workstation graphics. At thirty frames per second, however, the rotation will complete in just over a second – too fast for normal viewing. See the **Other Notes** section for some additional hints and tips.

BASIC OPERATION

All keyframe animation functions are controlled through the Keyframe Quick Interaction area. You can define the transformations between keyframes, or you can create standard animations

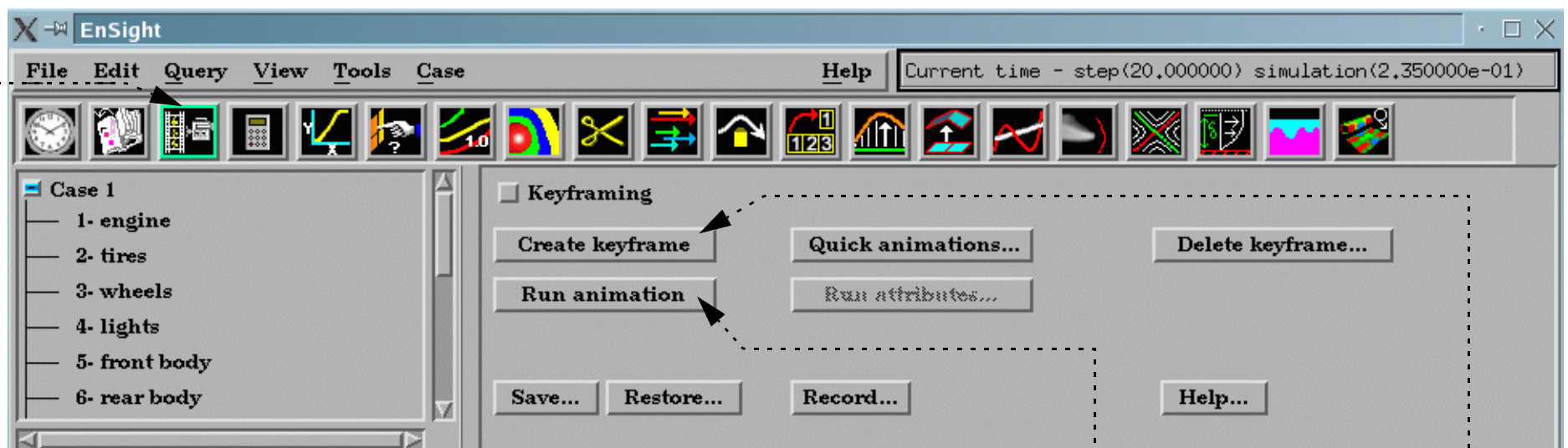

To define your own keyframes:

1. Click the Keyframe Animation icon in the Feature Icon bar.
2. Set all viewing parameters to the desired location for keyframe 1.
3. Click **Create Keyframe** to save the first keyframe.

Note that the Keyframing toggle is automatically switched on when you begin saving keyframes.

4. Change the viewing parameters to the desired location for keyframe 2.
5. Click **Create Keyframe** to save keyframe 2.

You can play your animation at any time to check your results. The animation will play the keyframe range specified in the Run From/To fields in Run Attributes...

6. Click **Run Animation** to play the animation.
7. Continue to change viewing parameters and click **Create Keyframe** until you have saved all desired keyframes.

Important Notes!

You can abort a running animation by moving the mouse into the animation display window and pressing the 'a' key.

If you toggle-off the Keyframing button, any keyframes currently defined will be deleted. If you wish to save a set of keyframes, click the Save... button.



There are many ways to specify the desired transformations between keyframes. See the following articles for more information:

- [How To Rotate, Zoom, Translate, Scale](#)
- [How To Create and Manipulate Frames](#)
- [How To Set LookFrom/LookAt](#)
- [How To Define and Change Viewports](#)

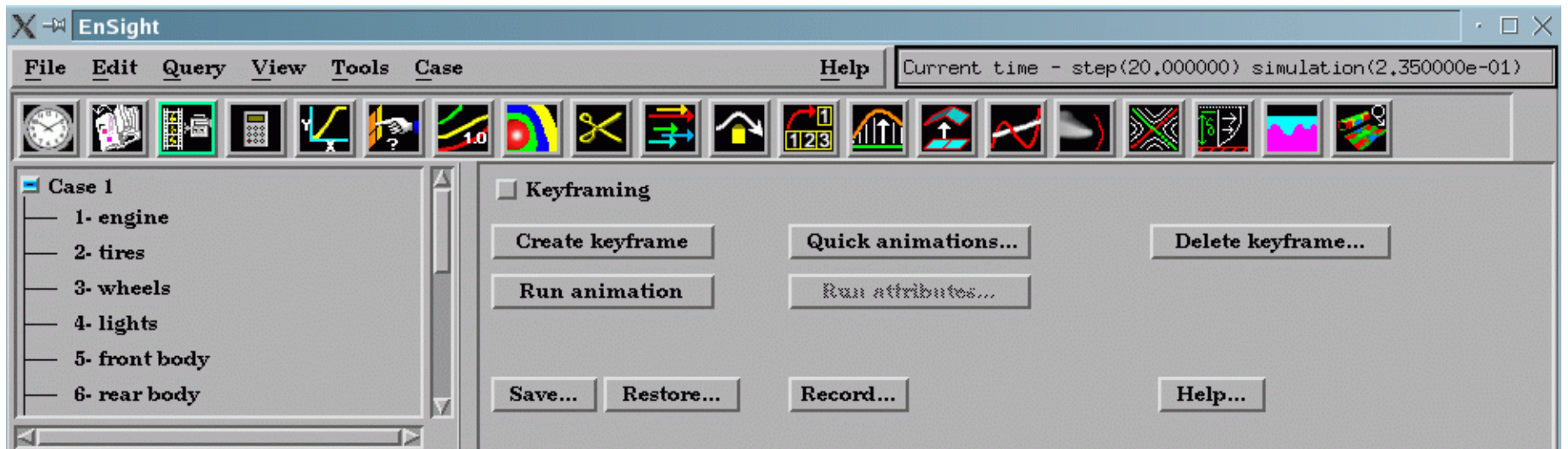

To Create Keyframes using Predefined Animations:

1. Click the Keyframe Animation icon in the Feature Icon bar.
2. Set all viewing parameters to the desired location for keyframe 1.
3. Click Quick Animations... to bring up the Keyframe Quick Animations Dialog.

In this dialog you will be able to create keyframes which define transformations which will (a) fly the viewer around your model, (b) rotate your model, or (c) create exploded views of your parts. Any one of these, or a combination may be used.

4. Set the number of frames which will be created
5. Acceleration at the first and last keyframes that will be created is on by default. If you do not want to accelerate/decelerate toggle these off.
6. Toggle Fly Around on if you wish to move the viewer (camera) in a circle.
 - (a) You can choose Right (start the viewer moving to the right) or Left.
 - (b) Specify the number of revolutions.
7. Toggle Rotate Objects if you wish to rotate the scene.

You can rotate positively or negatively about all three axis. For each axis you set the number of revolutions.
8. Toggle Explode View if you want your parts to be translated in reference to an origin.

You can specify the origin or set the origin to the transformation center.

Direction sets the explode direction and can be one of:

 - X,Y,Z - translate in the coordinate direction
 - XYZ - translate in the dominant coordinate direction
 - Radial - translate in the direction from the origin specified through the part centroid

The part that is farthest from the origin specified will be transformed Distance units

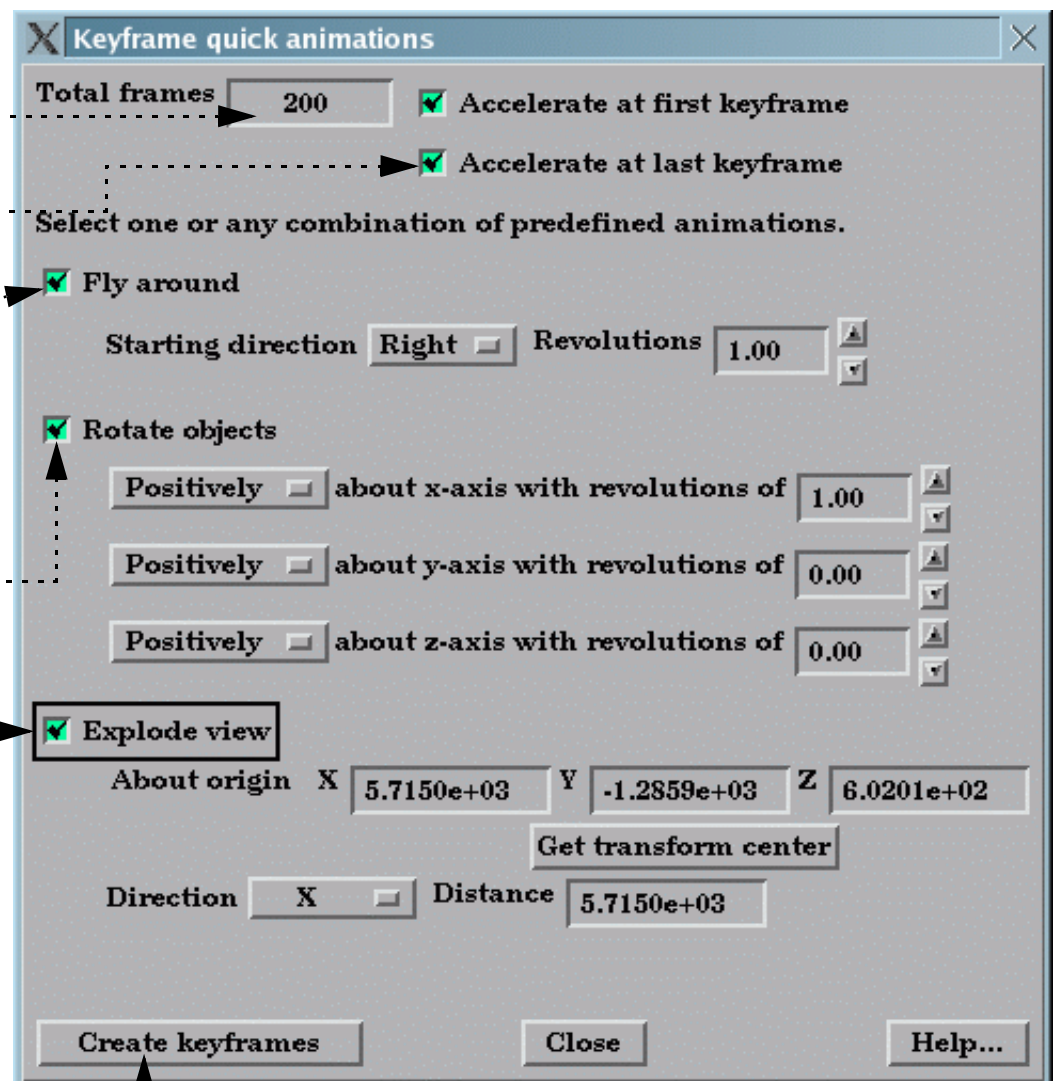

9. Click Create Keyframes to create the keyframes which will transform according to the selections made.



The following sections provide details on the animation control dialogs opened from Run Attributes... in the Keyframing Quick Interaction area.

Speed/Actions

The Speed/Actions tab allows you to set the number of sub-frames between each pair of consecutive keyframes as well as specify run attributes such as acceleration and commands to execute:

1. Click Run Attributes... in the Keyframing Quick Interaction area to bring up the Keyframe Run Attributes dialog.

2. Click the Set Speed/Actions tab.

3. Select the desired keyframe to edit: either enter the value or use the up/down buttons.

4. Enter the desired number of sub-frames between the keyframe selected in step 1 and the next (the default is 20).

5. If desired, set the number of frames to hold for the keyframe (default is 1).

6. If desired, enter EnSight commands to execute when the selected keyframe is reached. The command(s) will be executed before the frame is displayed.

7. If you added or changed the commands to be executed at a keyframe, click Update Commands.

8. If you want the transformation to accelerate out (or into) the keyframe, toggle Acceleration on.

9. Continue by selecting a new keyframe to edit and click Close when done.

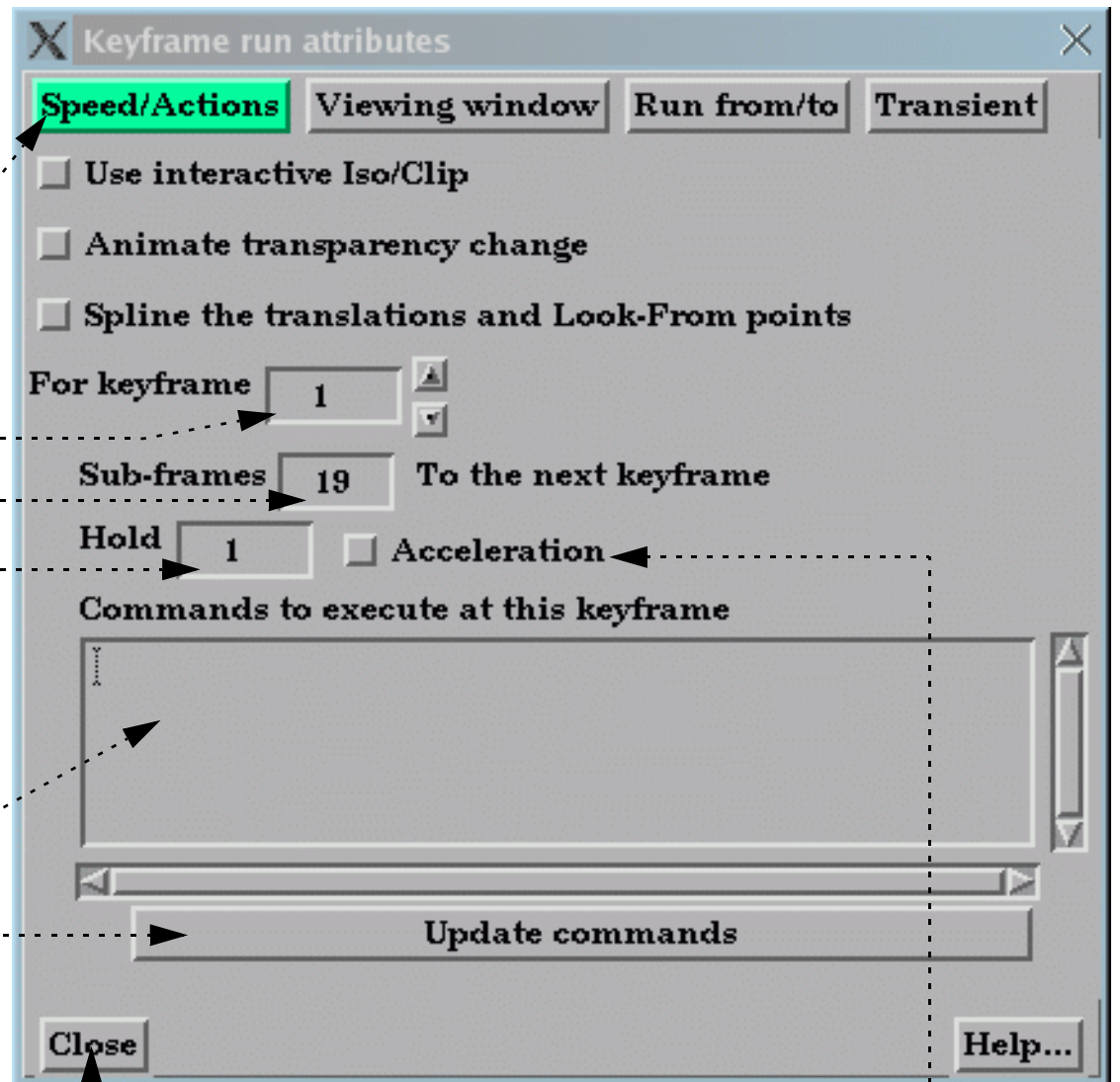

Use Interactive Iso/Clip

By turning this toggle on, any clip or isosurface interactively moved during the keyframe will animate.

Animate Transparency Change

By turning this toggle on, transparency changes to parts during the definition of the keyframes will be part of the animation.

The number of sub-frames controls the speed with which objects transform between keyframes. More sub-frames yields slower motion.

You can insert any valid EnSight command to be executed at a keyframe. If your command sequence is more than a few lines, it is best to save the sequence in a file and just enter the command `play: filename`. There is a special case of executing a command at a keyframe. If you insert the command `shell: filename`, The file `filename` (which is assumed to be a UNIX executable command) will be executed *after* each sub-frame and each surrounding keyframe. In addition, if you are saving animation frames to disk files, the name of the image file just written is passed to the executable as the first argument. This capability can be used to postprocess the image files, for example to resize and re-sample an image or copy it to a different location. If this capability is used, the `shell: filename` command must be the only command specified.



Viewing Window

The Keyframe Viewing Window tab allows you to set the size and location of the animation display window:

1. Click Run Attributes... in the Keyframing Quick Interaction area to bring up the Keyframe Run Attributes dialog.

2. Click the Viewing Window tab.

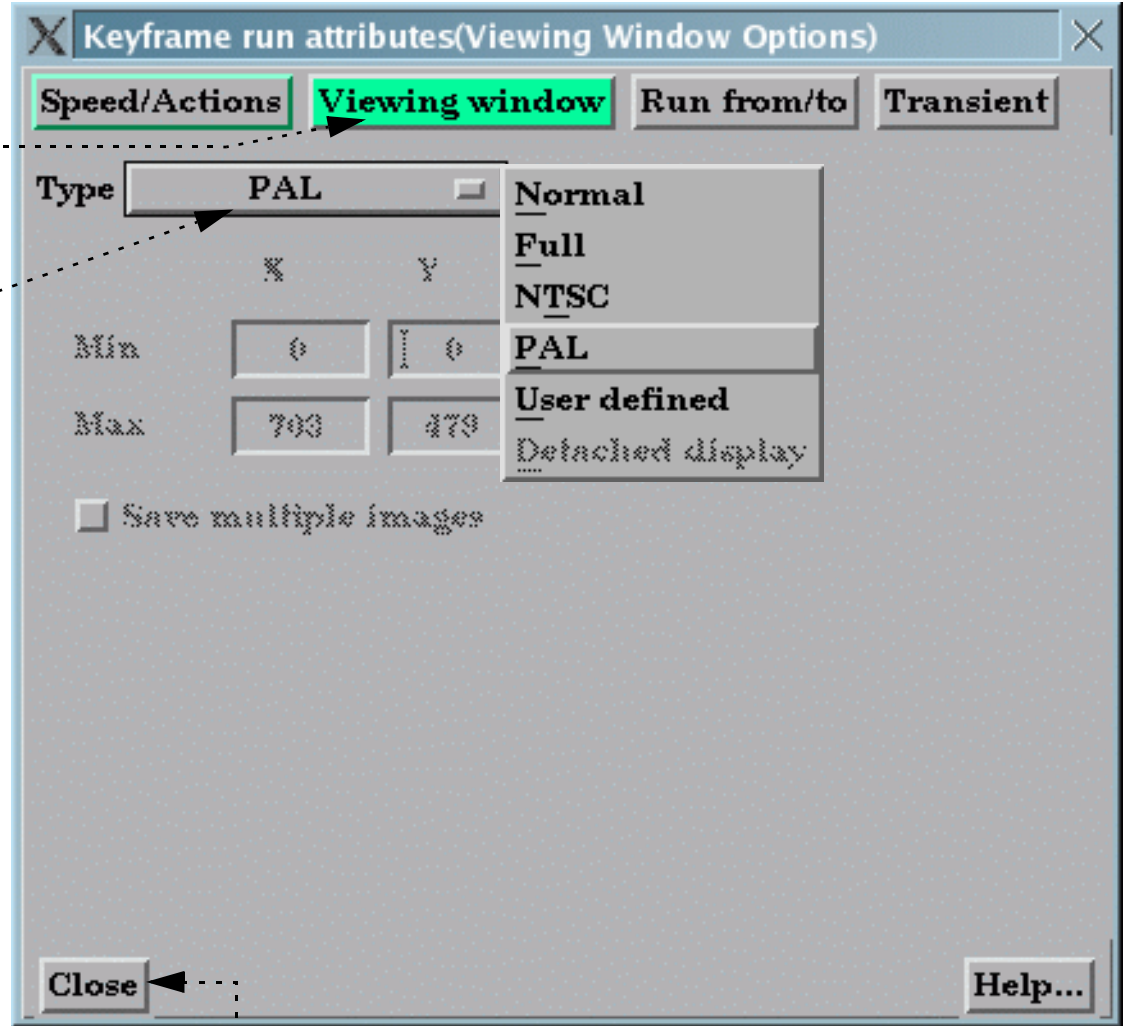

3. Select the desired window type:

4. Click Close.

Normal Use the current Graphics Window (initially 794 x 659)

Full Use the full screen with no window borders (typically 1280 x1024)

NTSC Use NTSC video resolution (640 x 480) and position at the lower-left corner

PAL Use PAL video resolution (720 x 576) and position at the lower-left corner

User Defined Use the Min/Max X and Y settings

Detached Display Use the detached display and set Min/Max settings

The Min setting for User Defined specifies the position of the lower-left corner of the animation window (as an offset from the lower-left corner of your monitor screen). The Max setting is the upper right corner of the animation window.

Run From/To

The Run From/To tab allows you to specify the range of keyframes to play.

1. Click Run Attributes... in the Keyframing Quick Interaction area to bring up the Keyframe Run Attributes dialog.
2. Click the Run From/To tab.
3. If you wish to limit the animation playback to certain keyframes set the Run From and To fields. By default they are set to cover all of the keyframes you have created.

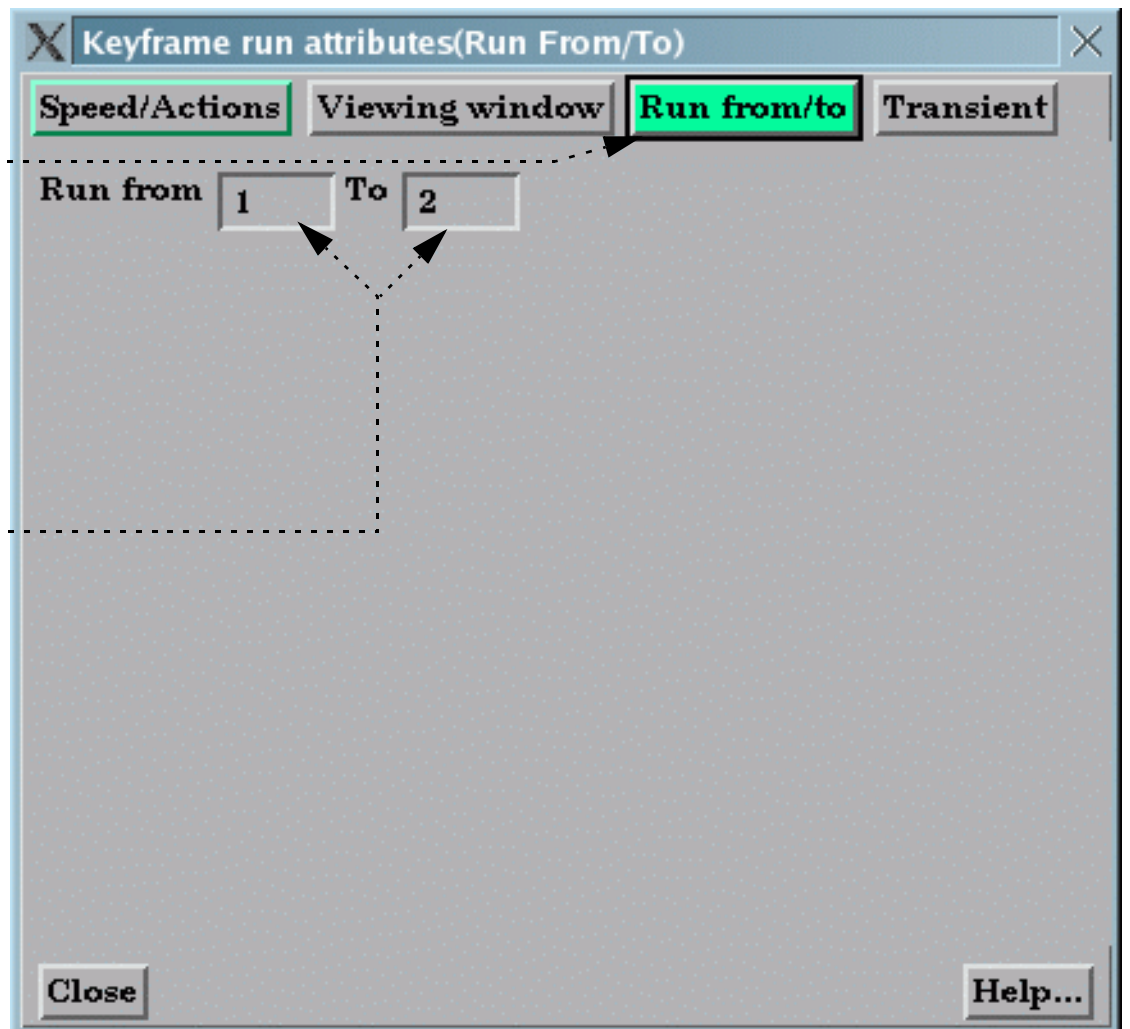



Transient

If you have transient data you can specify how it will be used during the keyframe animation.

1. Click Run Attributes... in the Keyframing Quick Interaction area to bring up the Keyframe Run Attributes dialog.

2. Click the Transient tab.

3. Toggle Use Transient Data on if you want to use transient data during the animation.

Transient data does NOT have to be on (and should not) to play back a flipbook animation during the keyframe animation.

4. Timelines allow you to use transient data during each defined timeline.

If the timelines do not cover all of the keyframes you will have a portion of your animation with no transient data.

By default a single timeline exists which covers all of the defined keyframes. To create more timelines click New

5. For each timeline you can specify the begin and ending time value (either step or simulation time - See Solution Time dialog).

6. Time will be interpolated such that the Start Time occurs at the Start At Keyframe and the End Time will occur at the End At Keyframe unless the Specify Time Increment is toggled on. If the Specify Time Increment is on each frame during the timeline is incremented by the time indicated.

If the Start Time or End Time is encountered before the Start At or End At Keyframes the transient data will either Loop (go back to the Start Time) or Swing (play in reverse).

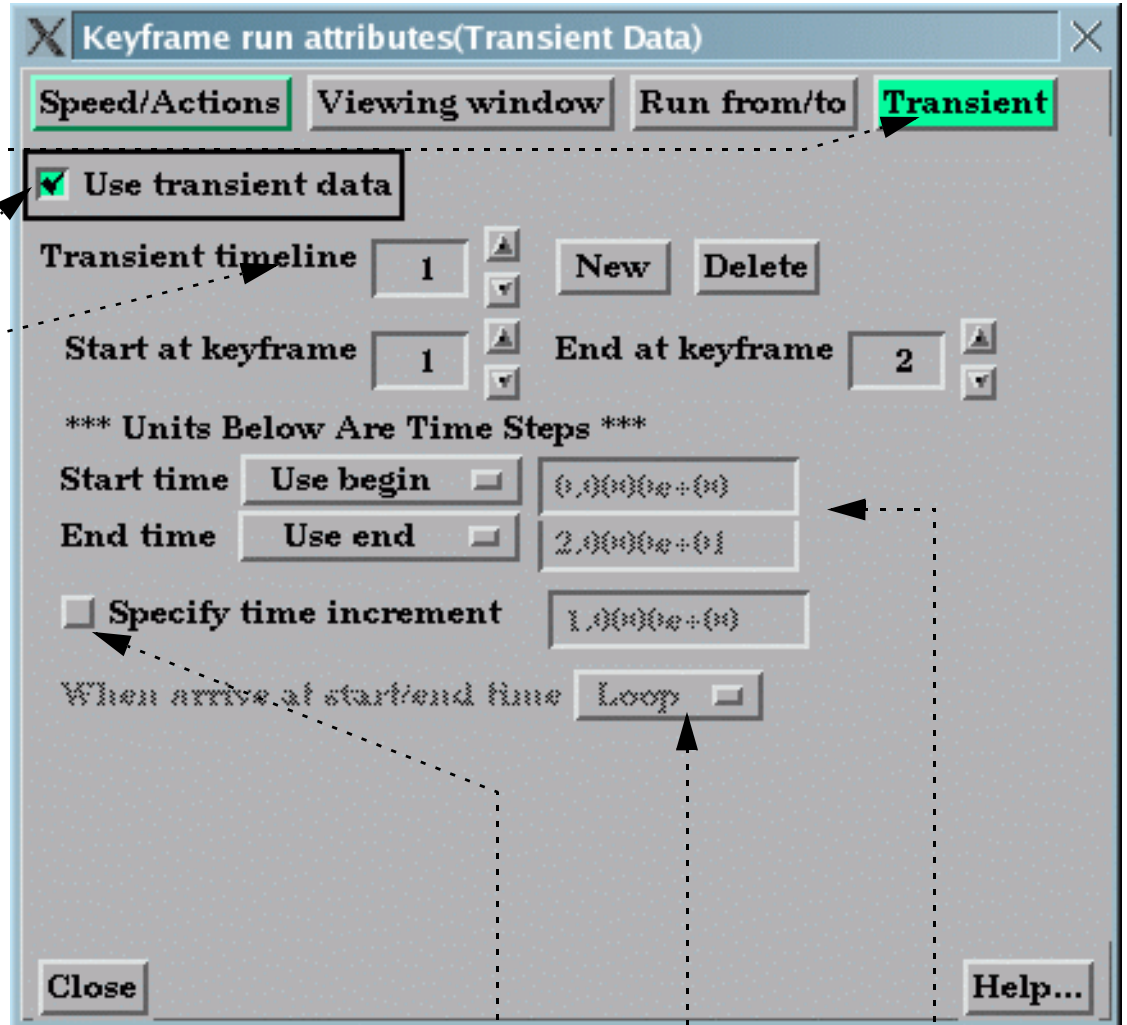

Record...

The Keyframe Animation Recorder dialog specifies the type of recording device:

1. Click Record... in the Keyframing Quick Interaction area.

2. Toggle on Record To File.

3. Select the desired file format and options.(see below).

4. Provide the File prefix.

5. Click Close.

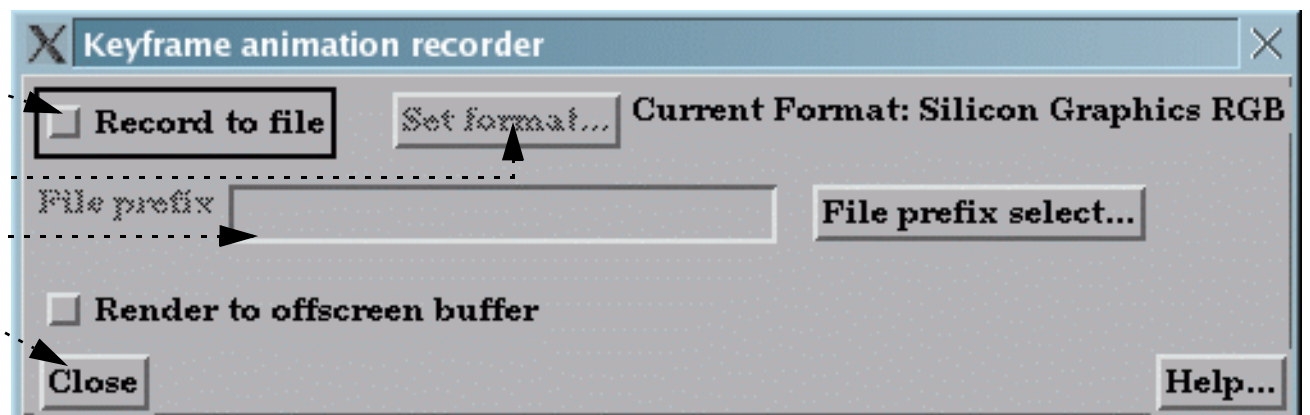



Available recording file formats:

Apple PICT	Flipbook files saved as sequence of Apple PICT files.
JPEG	Flipbook files saved as sequence of JPEG files.
TIFF	Flipbook files saved as sequence of TIFF files.
PCL	Flipbook files saved as sequence of Page Control Language files.
PostScript	Flipbook files saved as sequence of PostScript files.
Silicon Graphics RGB	Flipbook files saved as sequence of SGI RGB files.
TARGA	Flipbook files saved as sequence of TARGA files.
CEI RGB with depth	Flipbook files saved as sequence of RGB files with depth.
EnVideo	Flipbook files are saved to EnVideo file.
MPEG1 / MPEG2	Flipbook files are saved to an MPEG file.
AVI	Flipbook files are saved to an AVI file.
POVRAY Geometry	Flipbook files are saved as a sequence of POVray geometry files

Save and Restore

A set of keyframes and related information can be saved to disk and later restored. To save keyframes:

1. Click **Save...** in the **Keyframing Quick Interaction** area.
2. Enter the desired file name in the **File Selection** dialog and click **Okay**.

To restore previously saved keyframes:

1. Click **Restore...** in the **Keyframing Quick Interaction** area.
2. Enter the desired file name in the **File Selection** dialog and click **Okay**.

OTHER NOTES

As pointed out in the introduction to this article, high-quality animation takes time and experience. CEI has produced a great deal of animation over the years and has learned a variety of lessons. In the hope that EnSight users can avoid many of the pitfalls inherent in the process, many of these lessons and rules of thumb are presented here.

EnSight's keyframe animation methodology is borrowed from the animated film industry. In making animated films, the master animator defines how the scene will look at certain points in time (the keyframes) and then hands the work off to an "in-betweener", with instructions on how many frames to add between each pair of keyframes. The in-betweener then draws the missing frames. EnSight's approach is similar with the user as the master animator and EnSight as the in-betweener. Some of the strengths of this approach include:

1. When keyframing is on, EnSight is not only recording the viewing parameters when you click **Create Keyframe**, it also records the actions taken to get from the last keyframe to the current one. This approach permits certain operations to be performed without ambiguity (such as rotating by 180 degrees or more).
2. Each Viewport can be animated independently.
3. Flipbooks can be played during an animation.
4. Animated particle traces can be played during an animation.
5. Transient data is easily synchronized with the generated frames. When the animation is run, EnSight will automatically step through time and recalculate all time-dependent entities.
6. Output can go directly to disk files for later recording, manipulation, or conversion to other formats (e.g. MPEG or QuickTime).
7. Additional power and flexibility can be achieved since EnSight command language statements can be issued at keyframes.



The keyframe capability was designed to enable engineers and scientists to produce quality animation. As such, it lacks most of the more elaborate controls available in commercial animation packages (which typically cost 2-3 times more than EnSight). Some limitations:

1. Only transformation parameters (global, frame and camera transforms) are saved through the keyframing process. Other parameters and part attributes are not interpolated between keyframes.
2. Light sources are fixed in EnSight – they cannot move during the animation.
3. The shading and lighting model used by EnSight is fairly simplistic.

Tips for Video Recording

Animation Holds

Whenever an animation is started or stopped use a “hold” to allow your viewers to establish the visual context of the scene. A hold of 3 seconds at the beginning and 2 seconds at the end usually works well. For complex imagery, longer holds may be required. Note that a hold can typically be performed at the recording level – it is not necessary to have EnSight compute multiple frames for a hold.

Rate Control

The speed at which events occur during an animation is one of the most difficult aspects to master. Viewers become confused and disoriented if motion is too fast; too slow and your viewer may lose interest. The frame rate for NTSC (the video format used in North America) is 30 frames per second. Although there is a great deal of variation (depending on graphics hardware speed and model size), your workstation will typically have a much slower frame rate. Therefore, what appears to be good speed on your workstation may be much too fast when recorded to video at 30 frames per second.

Trial and error is one method to determine proper rates. Although you may end up doing some “line test” video recording to refine your rates, use the method described here to derive good starting values:

1. Define all the keyframes.
2. Set up the animation to play back at full screen.
3. Set up the animation to play only from the first to the second keyframe.
4. Set the number of sub-frames between keyframes 1 and 2 to be 300.
5. Select View > Bounding Box > Static Box.
6. Using a watch with a second hand, time how long it takes to play the animation. Call this time “T”. We know that it will take 10 seconds to play 300 frames on video. Compute the following:

$$\text{factor} = T/10.$$

For example, if you find T to be about 12 seconds, then factor is 1.2, which means that the rate you see on the screen is 1.2 times slower than what you will see on video.

7. Iteratively adjust the number of sub-frames between keyframe 1 and 2 (running the animation after each adjustment) until you like the rate you see on the screen.
8. Finally, adjust the number of sub-frames by the factor found in step 6. For example, if 150 sub-frames were required for a good rate of speed, then change the number of sub-frames to 150*factor to see the same rate on video.
9. Perform steps 3 through 8 for the next set of keyframes.

Transient Data

Animation is particularly useful for presenting transient data. However, since both viewing parameters and time can change simultaneously, the potential for confusing viewers is very high. In general, you should never change both viewing parameters and time simultaneously. It is typically much better to use transformations in an opening scene to present the model to the viewer. The transformations should end at a vantage point suitable for viewing the transient phenomena. At that point, the time-dependent data can be displayed. If you must alter the scene during transient display, do so with great care to avoid disorienting viewers.

Note that you can animate time-dependent information without transformations by merely creating two keyframes without performing any transformations between them.



In many instances, there will not be enough time steps in the simulation to produce an animation of adequate duration. If the simulation does not involve changing geometries, EnSight can interpolate between time steps (linearly) to yield additional frames. However, keep in mind that your simulated phenomena is almost certainly not linear in nature. If you have EnSight generate more than a few interpolating frames between each actual time step, the resulting discontinuity at keyframes (from the piece-wise linear interpolation) is quite visible in the resulting video.

Frame count

The total number of frames that EnSight will produce during the animation is the sum of all sub-frames plus the number of keyframes. This is especially important to keep in mind when synchronizing transient data with animation frames.

Animated Traces

If you display animating particle traces during keyframe animation, you may have noticed that the trace animation always resets at the beginning of the keyframe animation. However, in most cases it is desirable to have the trace animation fully in progress when the animation begins. This can be accomplished by creating an additional keyframe at the beginning of the animation. Set the number of sub-frames between keyframes 1 and 2 to a value high enough to yield the desired tracer saturation. When you run the animation, set the Run From field to 2 so that the animation begins generating frames with keyframe 2. At that point, the tracer animation process will have executed once for each sub-frame between keyframes 1 and 2.

Color

The color gamut (the range of colors a device is capable of displaying) of video (especially NTSC) is significantly less than that of your workstation monitor. The result is that certain colors that look fine on your workstation cannot be reproduced on video. Fully saturated colors (especially red and blue which “bleed” across the screen) are particularly troublesome. However, it is quite easy to de-saturate your images prior to recording. There are actually three ways to do this:

1. Modify all of the colors in use to de-saturate them. For example, if a color is pure red (1., 0., 0.), change it to be a more pastel red (.85, .1, .1).
2. Modify the saturation factor in the Image Format Options. A factor of 0.85 is usually good.
3. Create your animation, then de-saturate the images using an image tool such as the one available from the San Diego Supercomputing Center (it's free). This will only work, of course, if you are saving animation images to disk files.

Dark backgrounds work much better than light backgrounds. Black is often the best choice.

Lines

Moving single-width lines have a tendency to “crawl” on video. Use a minimum line width of 2.

Anti-aliasing

Without correction, computer-generated imagery exhibits aliasing artifacts that typically show up as jagged edges. For our purposes it is sufficient to say that aliasing results from sampling at a resolution too low to capture the “signal” represented by the underlying geometry. We can only sample our geometry at the available pixels. Since the effective number of pixels in the NTSC video signal is only one quarter the number of your workstation screen, what looks fine on your workstation may be less than acceptable on video. Although EnSight provides no direct anti-aliasing support, there are ways to mitigate this problem.

1. If you are recording images from EnSight directly to a video recorder, use a scan converter (a piece of hardware) to filter full screen images to NTSC resolution images.
2. If you are recording images to disk files, record them at full screen resolution and then use an image re-scaling tool (such as izoom on SGI hardware) to down-sample the images to the desired video resolution. This down-sampling averages several pixels to yield one output pixel, effectively preserving much of the resolution contained in the original full screen image.

Annotation

The smallest annotation text that can be clearly read on video has a font size of 40. For title sequences, use a size of about 65.





If you display parts colored by variables, you should always include the applicable color legend so viewers understand what the coloration represents. For color legends, it is often sufficient to display just one value at the top (the maximum) and one at the bottom (the minimum) in addition to the name of the variable. In fact, sometimes just using “High” and “Low” are sufficient if only the relative magnitudes of the variable are important.

Screen Space

The region of a video display that is “safe” for viewing is typically smaller than your animation display window. You should plan your scenes such that objects of interest (especially annotation entities) do not come “too close” to the edge. If you keep these objects within the range (in EnSight viewport coordinates) .06 to .94 for X (width) and .05 to .95 for Y (height) you should be safe.

Introductory Sequence

Your animation should begin with some title slides explaining the problem domain to your viewers. Try not to put too many words on any one slide and display each one for at least four seconds.

Next, before displaying your results, provide a sequence that introduces viewers to your model. This sequence should be long enough and complete enough to orient the average target viewer to your problem. It is difficult to overestimate the need for this sequence. Without it, viewers are often confused and disoriented for the entire animation.

Credits

You should always include proper credits on any animation you produce. Even animations initially intended only for internal consumption often end up shown to broader audiences.

Stretching an Animation

Ten minutes of video requires 18,000 frames. Only after you have created your first animation will you realize that this can represent a logistical nightmare. In many cases, you can reduce the number of generated frames required using each frame multiple times. If you record two video frames for each actual frame you have, in effect, slowed your animation by half since there are only 15 new frames per second. Although 15 frames per second produces less smooth motion than 30, it is still usually acceptable. Further reduction however, say to 10 unique frames per second, produces noticeable jerkiness.

The Recording Process

There are three basic ways to go about recording your animation:

1. The cheapest method (and the one that typically yields the poorest results) is to simply record the animation directly off the workstation. This can be done either by pointing a video camera at the screen or using the built-in video out signal available on some workstations.

Although this may be suitable for some simple steady-state problems, the resulting video is usually of very poor quality. Note also that the frame refresh rate is dependent on the complexity of your geometry (which can vary throughout the animation) and the speed of your hardware.
2. EnSight can also write each generated frame to a disk file. Given the current state-of-the-art in hardware and software for video production, this is the preferred method. The images can be further manipulated on disk (e.g. color de-saturation or pixel averaging) prior to recording. If a problem occurred, missing or bad frames can be regenerated. Tools also exist to convert sequences of image files to popular animation formats such as MPEG and QuickTime.
3. EnSight can directly output popular animation formats, including MPEG, AVI and its own format - EnVideo.

SEE ALSO

User Manual: [“Keyframe Animation” on page 12](#)



INTRODUCTION

EnSight's powerful particle tracing facility can trace particles (either steady-state or transient) through flow fields. Animating the resulting traces often promotes intuitive comprehension of the characteristics of the underlying flow field. Traces are animated by displaying one or more *tracers* on all traces of the trace part. A tracer moves along the path of a trace with length proportional to the local velocity. EnSight provides complete control over all aspects of the tracers including length, speed, and release interval for multiple pulses.

This article covers particle trace animation and assumes that you have already created one or more particle trace parts. See [How To Create Particle Traces](#) for more information.

BASIC OPERATION

To enable particle trace animation and adjust the animation parameters:

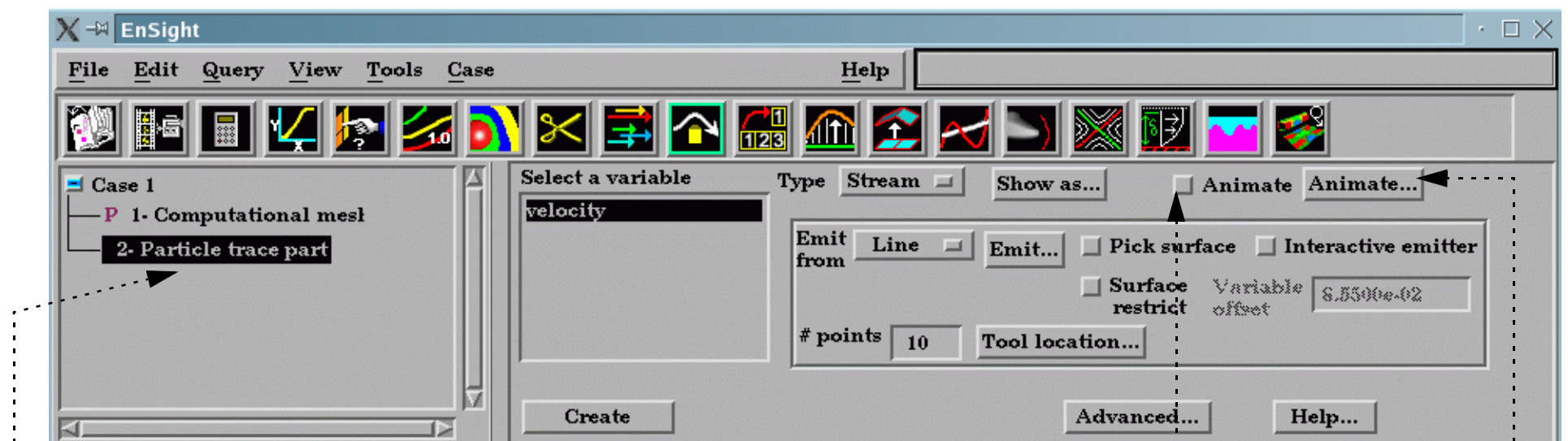

1. Double-click the desired particle trace part in the Main Parts list.
2. Toggle on Animate in the Quick Interaction area.
3. Click Animate to open the Trace Animation Settings dialog. Make changes as desired (remember to press return for changes to text fields).

Set the color of the tracers to either Trace Color (*i.e.* the same color as the parent trace part) or Constant (and set the desired color using the Mix... button or the RGB fields).

Set the line width of the tracers.

If transient traces (pathlines), set the Start Time and/or Max Time.

Set the tracers length factor (see below).

Set the tracers speed factor (see below).

Set tracers head representation. Either None or Spheres. If Spheres, the radius can be Constant (set by the Scale value) or sized by a variable and scaled by the Scale value. Sphere detail set via Detail field:

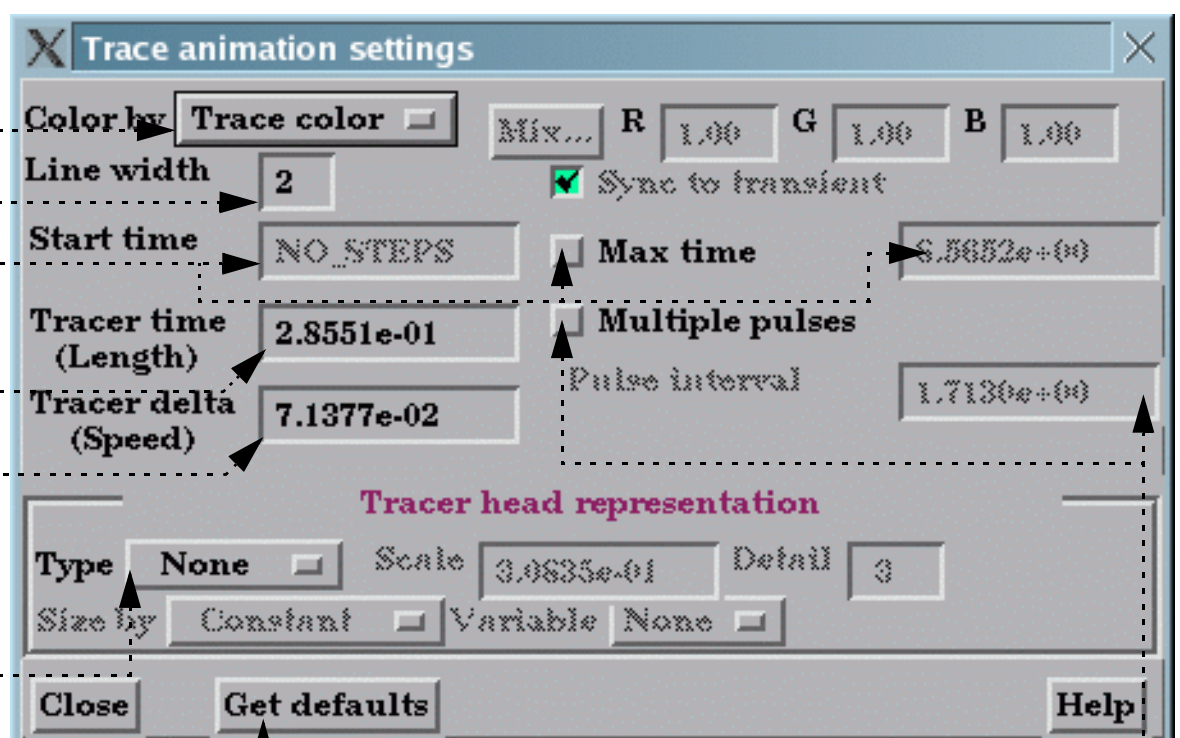

Click to load good default values to the Tracer Time, Tracer Delta, and Pulse Intervals fields.

Toggle on Multiple pulses and set the interval between pulses (see below).



Tracer Parameter Descriptions:

Tracer Time (Length)	The Tracer Time (Length) parameter acts as a scaling factor for all tracer lengths (the higher the value the longer the tracer). Tracer length varies as the local velocity changes along the trace. For example, the tracer will lengthen as the leading edge of the tracer moves into a higher velocity region.
Tracer Delta (Speed)	The Tracer Delta (Speed) parameter acts as a scaling factor for the tracer speed (the higher the value the faster the tracer). The speed of the leading and trailing tracer edges varies as the local velocity changes along the trace.
Pulse Interval	The interval between successive tracer emissions when in multiple pulse mode (the higher the value the longer the interval between pulses). Note that the distance between tracers will increase when the local velocity increases.

Record...

Once traces are animating, they can be recorded.

The “Record current graphics window animation” icon will be on.



Click it to open the Save Animation dialog.

Set the recording format, and the window size under the Record and Advanced tabs.

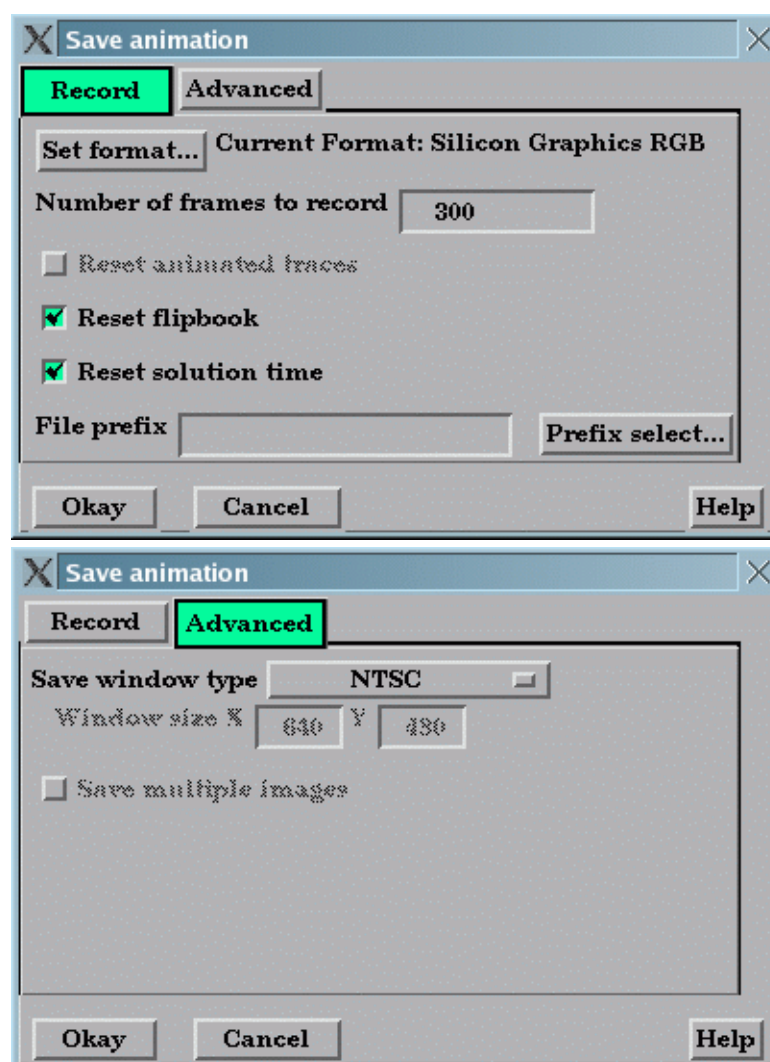

Available recording file formats:

Apple PICT	Flipbook files saved as sequence of Apple PICT files.
JPEG	Flipbook files saved as sequence of JPEG files.
TIFF	Flipbook files saved as sequence of TIFF files.
PCL	Flipbook files saved as sequence of Page Control Language files.
PostScript	Flipbook files saved as sequence of PostScript files.
Silicon Graphics RGB	Flipbook files saved as sequence of SGI RGB files.
TARGA	Flipbook files saved as sequence of TARGA files.
CEI RGB with depth	Flipbook files saved as sequence of RGB files with depth.
EnVideo	Flipbook files are saved to EnVideo file.
MPEG1 / MPEG2	Flipbook files are saved to an MPEG file.
AVI	Flipbook files are saved to an AVI file.



ADVANCED USAGE

If you have time-dependent data and have calculated transient particle traces (pathlines), you can enable trace animation, load a transient flipbook, and view the animating pathlines simultaneously with the dynamic flipbook. See [How To Create Particle Traces](#) and [How To Animate Transient Data](#) for more information.

OTHER NOTES

The parameters in the Trace Animation Settings dialog are *not* specific to the currently selected particle trace part – the settings apply to all currently animating particle trace parts.

SEE ALSO

User Manual: [Particle Trace Animation](#)



Annotate
Create Color Legends

INTRODUCTION

Every currently active variable has an associated color legend that can be displayed in the Graphics Window. Color legends provide essential information about images that use parts colored by variable values (color fringes). Legends are particularly important if the image is to be viewed by others.

Legends are drawn as a vertical or horizontal color bar with associated variable values. The size and position of the color legend can be changed. This article discusses changing the appearance of color legends using Annotation mode. To edit the color palette itself (change colors or change the mapping from variable values to colors) see [How To Edit Color Palettes](#).

BASIC OPERATION

To display a color legend:

1. On the desktop, click the Variable legend visibility button.



2. Click the variable legend(s) you wish to display (or not display).

The list contains legends for scalar variables and for magnitude of vector variables. The components of vector variables will become available in the list if Show Components is toggled on.

More than one legend can be selected concurrently.

A button is provided to allow you to easily turn them all off.

You can also easily get to the palette editor from here.

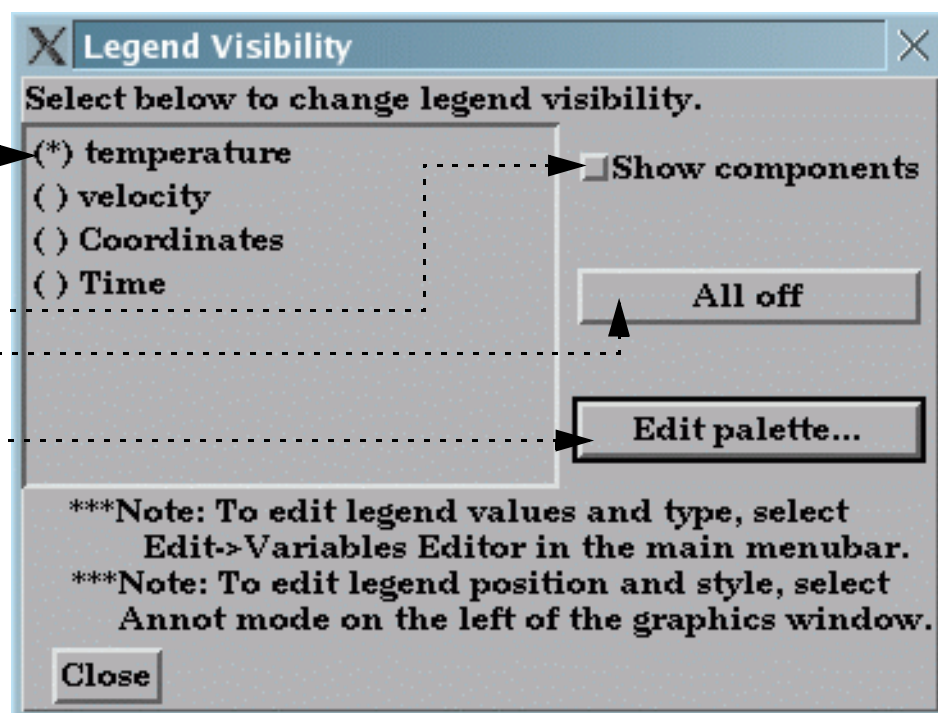

Note: () indicates legend not currently visible,
(*) indicates currently visible legend.



Resize or Reposition Color Legends in Graphics Window

In Annotation Mode, color legends can be selected in the graphics window and then scaled or moved:

1. Make a color legend visible as described above.

2. Click Annot in the Mode Selection area.

Like other annotation entities, color legends must be selected prior to performing an operation. A selected color legend has handles surrounding the color bar colored in the highlight color (typically green). Unselected color legends have white handles.

3. Select the desired color legend: move the mouse into the Graphics Window and click the left mouse button anywhere within the color bar.

4. To move the color legend, place the mouse pointer within the color bar, click the left mouse button, and drag to the desired location.

5. To resize the color legend, place the mouse pointer over one of the four corner handles, click the left mouse button, and drag to the desired size.

Handles (currently selected)

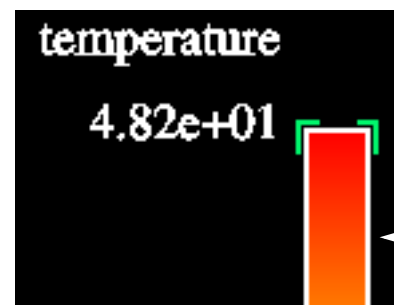

Manipulating Other Legend Attributes

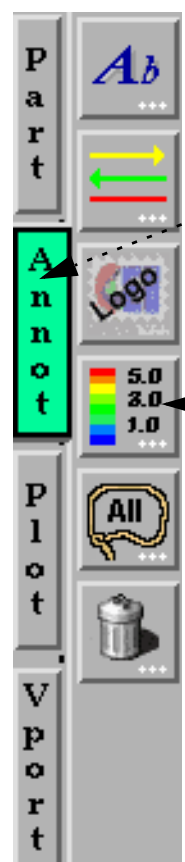

1. Click Annot in the Mode Selection Area.

2. Click Legend icon from the Mode Icon Bar to bring up the Annotation dialog.

3. Select the legend(s) of interest in the list (or in the graphics window), then:

To change visibility:

Toggle Visible on or off.

To change color of text and colorbar outline:

Select the desired color from the matrix, enter RGB values in the fields, or click More... to open the [Color Selector](#) dialog.

To change legend orientation:

Click the desired Layout (Vertical or Horizontal).

To change title position:

Click the Title Pulldown and select either Above (the default), Below, or None.

To change text position:

Click the Values Pulldown and select either Left/Bottom (the default), Right/Top, or None.

To change legend type:

Click the Type Pulldown and select either Continuous (the default) or Discrete.

To change text size:

Enter the desired text size and press return.

To change Value label format:

Either select a pre-defined format from the Value format List or enter a new format string in the Text Format field.

To change location:

Enter values for X & Y (lower left corner) and width and height, and press return.

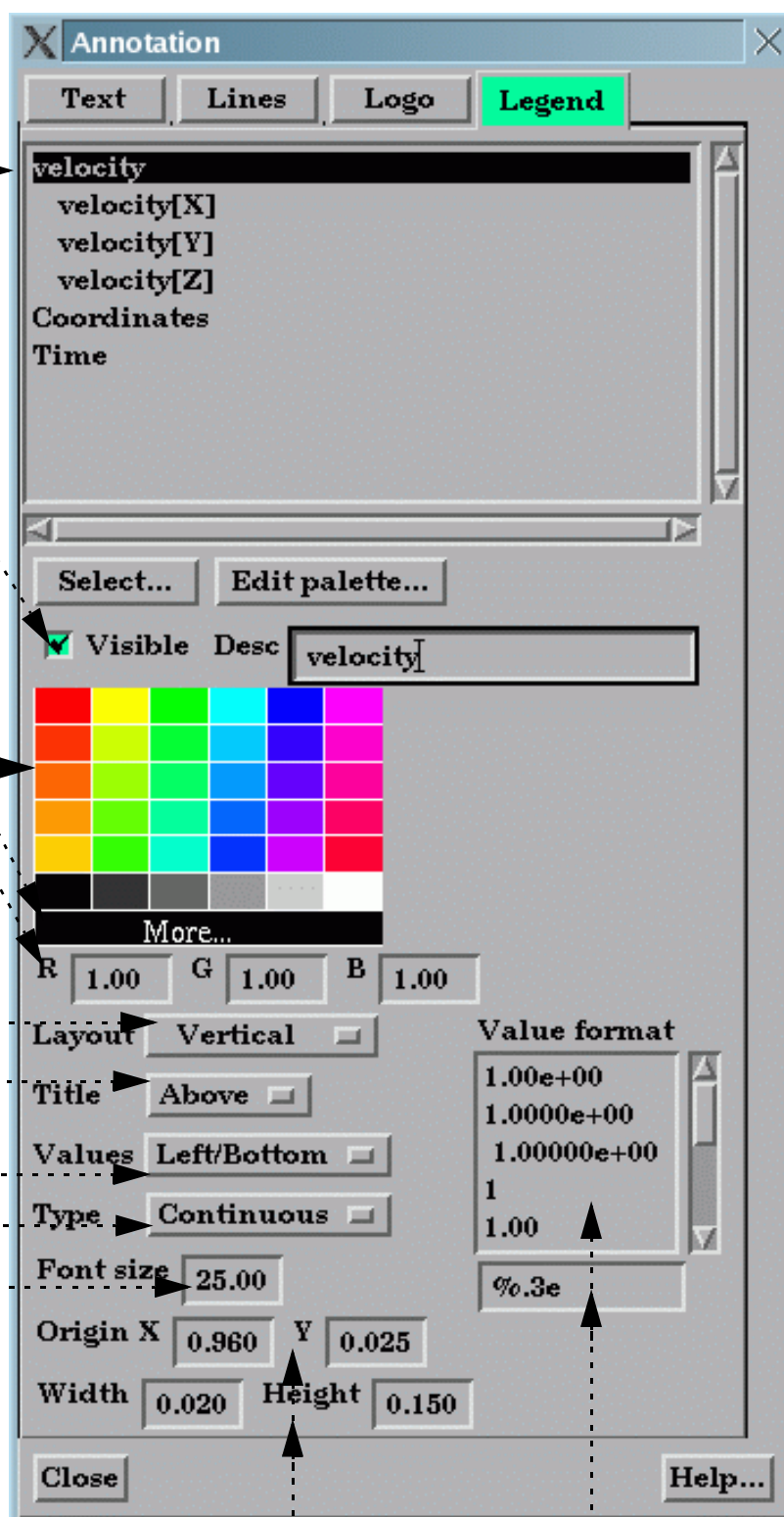



SEE ALSO

[How To Edit Color Palettes](#)

User Manual: [Annot Mode](#)





Create Lines and Arrows

INTRODUCTION

EnSight can display 2D lines with or without arrowheads. These annotations overlay the Graphics Window and are not associated with any viewport.

BASIC OPERATION

1. Click Annot in the Mode Selection Area.
2. Click Line icon from the Mode Icon Bar to bring up the Annotation dialog.
3. Create a new line in the Graphics Window by clicking the New button.

The Annotation dialog box has tabs for Text, Lines, Logo, and Legend. The Lines tab is active. It contains a list of lines: (0) Line and (1) Line. Below the list are buttons for Select..., New..., and Delete. A checkbox for Visible is checked. A color selection matrix is shown with a 'More...' button below it. RGB input fields are set to R: 1.00, G: 0.00, B: 0.00. A Width pulldown menu is set to '1 pixel'. An Arrows pulldown menu is set to 'On first end'. Origin X1, Y1, X2, and Y2 input fields are present. Buttons for Close and Help... are at the bottom.

To manipulate a line attributes, first select the line(s) of interest in the list (or while in Annot Mode, pick them in the graphics window), then:

To change visibility:

Toggle Visible on or off. Note that in Annot Mode invisible lines are drawn in a subdued color.

To change color:

Select the desired color from the matrix, enter RGB values in the fields, or click More... to open the [Color Selector](#) dialog

To change location:

Either select the center of the line and drag it to the desired location, or type appropriate coordinates in the X1, Y1, X2, and Y2 endpoint fields.

To change orientation and length:

Either select and drag the endpoints of the line to the desired location, or type appropriate coordinates in the X1, Y1, X2, and Y2 endpoint fields.

To change line width:

Click the Width Pulldown and select the desired line width.

To change Arrowhead status:

Click the Arrows Pulldown and select the desired state.

To delete a line, click the Delete button.

1 pixel
2 pixels
3 pixels
4 pixels

None
On first end
On second end
On both ends



SEE ALSO

User Manual: [Annot Mode](#)





Create Text Annotation

INTRODUCTION

EnSight has comprehensive features for text annotation. Not only can you display and position user-specified text, you can also display text contained in the description lines of some data formats as well as dynamic text that changes over time.

BASIC OPERATION

1. Click Annot in the Mode Selection Area.
2. Click Text icon from the Mode Icon Bar to open the Annotation dialog.
3. Click the New button, which will open the Text annotation creation dialog. Make sure it is in Create mode.

The **Annotation** dialog has tabs for Text, Lines, Logo, and Legend. The Text tab is active, showing a list of annotations: (0) Testing 1, 2, 3 and (1) Another String. Below the list are buttons for Select..., New..., Edit..., and Delete. A **Visible** checkbox is checked. A color selection grid is shown with RGB values (R: 1.00, G: 1.00, B: 1.00). Justify is set to Center, Size is 50, Rotation(Degrees) is 0, Origin X is 0.250, Y is 0.250, and Relative to viewport is 0.

The **Text annotation creation/editing** dialog shows the **Operating mode** set to Create. The **Text** field contains "Testing 1, 2, 3". Below the text field are radio buttons for Normal (selected), Superscript, and Subscript. A **Special coded items** list includes: Symbols, Constant Variable, Date, Geometry Header, Measured Header, Variable Header, Part Value, and Part Description. An **Insert special item** button is to the right. The dialog has Close and Help... buttons at the bottom.

4. Enter the desired text, and hit a return in the field. The text should now show up in the graphics window.

While entering text, you can change the script to super, sub, or normal by clicking the Superscript, Subscript, or Normal buttons which will insert <sup>, <sub>, or <no> into the string.

The **Special Coded Items**, which can be inserted into a string are discussed below.



To manipulate text string attributes, first select the string(s) of interest in the list (or while in Annot mode, pick them in the graphics window), then:

To change visibility:

Toggle Visible off or on. Note that in Annot Mode, the text will not be completely invisible but will be displayed in a subdued color.

To change color:

Select the desired color from the matrix, enter RGB values in the fields, or click More... to open the [Color Selector](#) dialog.

To change justification:

Select the desired Left, Right, or Center justification from the Justify pulldown.

To change text size:

Either resize the text interactively by grabbing the Resize Point of the text string (bottom right) and dragging, or by precisely specifying the font size in the Size field of the dialog (or using the slider to change the font size).

Important Note! The text size specified is relative to the size of the Graphics Window. If you increase the size of the Graphics Window, all text will also rescale to maintain the same relative size.

To change text rotation:

The orientation of text about the text justification point may be specified interactively by grabbing the Rotation Point of the text string (cross shape at upper right) and rotating the text to the desired orientation, or by precisely specifying the rotation angle (in degrees) in the Rotation field (or using the slider to change rotation angle).

To change location of the justification point in the graphics window:

Either interactively drag the text to the desired location, or precisely specify the location in the Origin XY fields.

You can also specify the viewport that the text is to be positioned relative to. If 0, the position is relative to the graphics window.

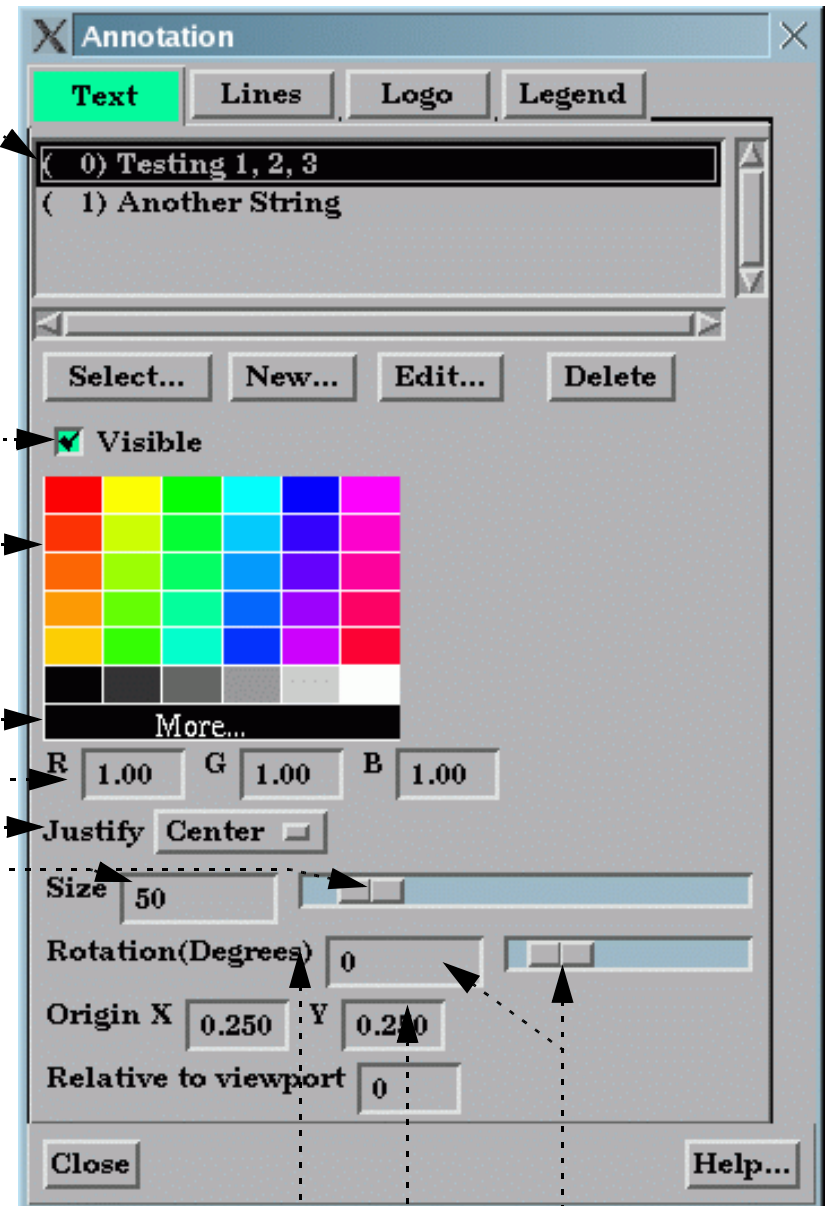



Special Coded Items

EnSight can automatically build text strings based on information from various sources. To use one of these special strings, select the desired item from the Special String list, select any required options, and click Insert Special String. A code will be inserted into the Text field. Hit return in the Text field to create the text entity and display it.

The following special strings are available. If multiple cases are loaded, any reference to parts or variables applies to the currently selected case (select Case > *casename* to changes cases)

Symbols	Brings up a symbol dialog. Click on any symbol to insert it at the current character insertion point of the string. The symbol will be inserted in to the string via a <sy>xxx, where xxx is the ASCII number for the selected symbol.
Constant Variable	The value of a constant variable (such as Time or Length). Select the variable from the Constant Variables list and select the desired numeric display format from the Number Format list. If the constant variable changes, the corresponding text will automatically update. This is very useful for displaying the current solution time during a transient animation.
Date	Current date. Example: Wed Jan 1 12:34:56 1997
Geometry Header	The first or second text line of the geometry file of the current case. Select Line 1 or Line 2.
Measured Header	The first line of the measured (discrete) data file of the current case.
Variable Header	The first line (typically the description line) from a variable file. Select the desired variable from the Variable(s) list.
Part Value	The "value" of a part. Currently only works for isosurface parts where the value is the corresponding isovalue. Select the isosurface part in the Part(s) list and select the desired numeric display format from the Number Format list.
Part Description	The description of the part as displayed in the Main Parts list. (Note that you can change this text by editing the Desc field in the applicable Feature Detail Editor for the part.)
Version	The name and current version number. Example: EnSight Version 6.0.

Delete Annotations

Existing annotations can be deleted in the Annotation dialog or can be selected and the Delete icon can be clicked:



Select All

You can select all of the current annotation type by clicking:---



SEE ALSO

User Manual: [Annot Mode](#)



INTRODUCTION

EnSight can display bit mapped graphics loaded from disk files. A bitmap can be any image, however, the most common use is to include a logo or other signature graphic to identify the source of images or animations. Bitmaps are drawn over all geometric objects in the Graphics Window (at least where the bitmap is opaque), but under all other annotation entities.

Bitmaps are stored in X Pixmap(.xpm) or (.bmp) format. See the **Other Notes** section for more information.

BASIC OPERATION

To load a logo:

1. Select Annot in the Mode Selection Area
2. Click the Logo icon from the Mode Icon Bar to open the Annotation dialog.
3. Click New button and select the desired .xpm or .bmp file using the File selection dialog which comes up, and click Okay.

The Annotation dialog box shows the 'Logo' tab selected. It contains a list of logos, with '(0) cei_logo.xpm' visible. Below the list are buttons for 'Select...', 'New...', and 'Delete'. A 'Visible' checkbox is checked. Below that are input fields for 'Origin X' (0.018), 'Y' (0.851), 'Scale X' (1.000000), and 'Y' (1.000000). At the bottom are 'Close' and 'Help...' buttons.

To manipulate logo attributes, first select the logo(s) of interest in the list (or in the graphics window), then:

To change visibility:

Toggle Visible off or on. Note that in Annot Mode, the logo will not be completely invisible but will be displayed in a subdued color.

To change location in the graphics window:

Either position the logo interactively by selecting the desired logo in the Graphics Window (while in Annot Mode) and dragging it to the desired location, or specify the precise coordinates in the X and Y fields:

To change size:

Typing the desired scaling factors into the X & Y fields and press return.

Note that the size of a logo cannot be adjusted interactively.

OTHER NOTES

The X Pixmap format is a widely used format for storing pixel maps for use in X Windows environments. For more information on the format, visit <http://koala.ilog.fr/lehors/xpm.html>. In the Windows world, .bmp files are widely used and understood.

Please note that EnSight requires that the color values in the .xpm files be hex numbers. Color names cannot be used. The program "xv" seems to convert them such that EnSight can read them if your application uses color names.



SEE ALSO

User Manual: [Annot Mode](#)

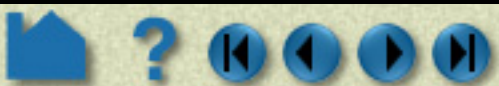



Configure EnSight
Customize Icon Bars

INTRODUCTION

EnSight uses several sets of icons to group functionality. To suit personal preferences or simplify the interface, the order of the icons within each set can be changed or icons can be removed altogether (typically eliminating access to that portion of functionality).

The icon sets correspond to the seven major groupings of function within EnSight: Main Feature (the icons in the Feature Icon bar) and the six Modes: View, Part, Annot, Plot, VPort, and Frame. By default, EnSight displays informative text labels underneath each icon in the Mode icon bars. Once the icon functions have been learned, these can be removed to save space in the icon bar.

BASIC OPERATION

To customize an icon bar:

1. Select **Edit > Preferences...**, select **General User_Interface** and click the **Modify and Save Icon Layout...** button.

2. Select the desired icon bar from the **Which Icon Bar** pulldown.

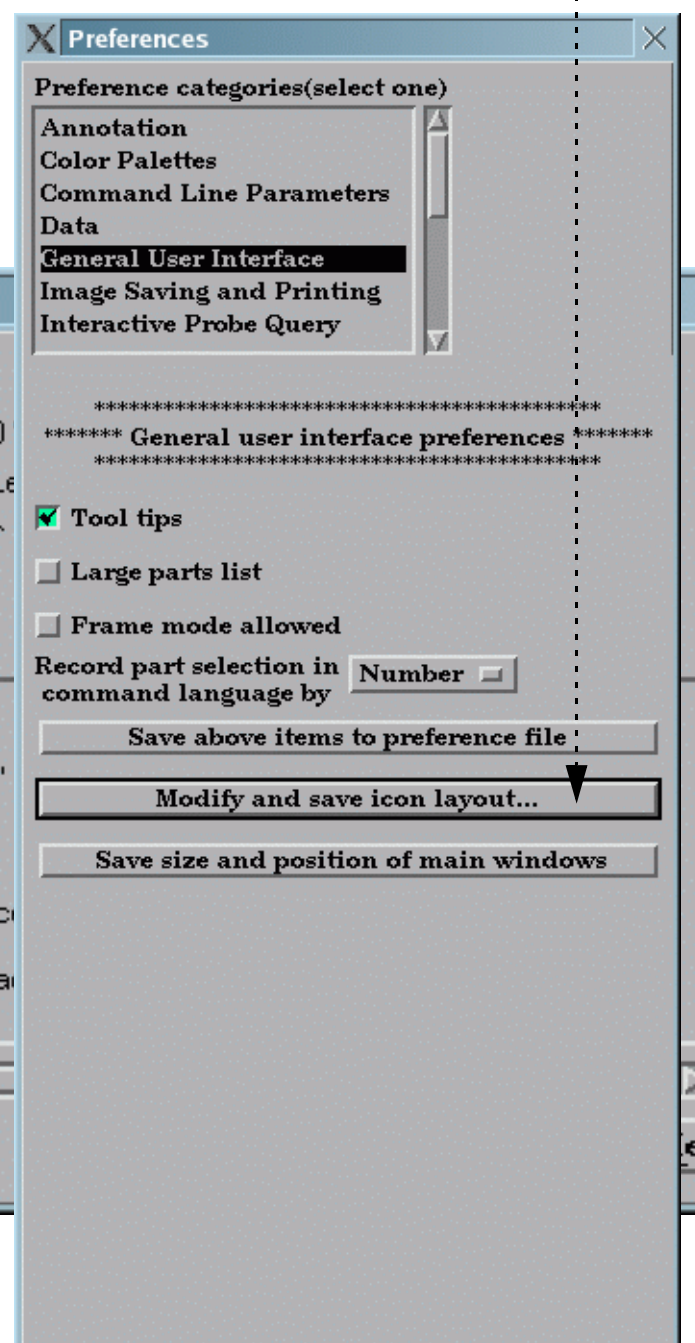
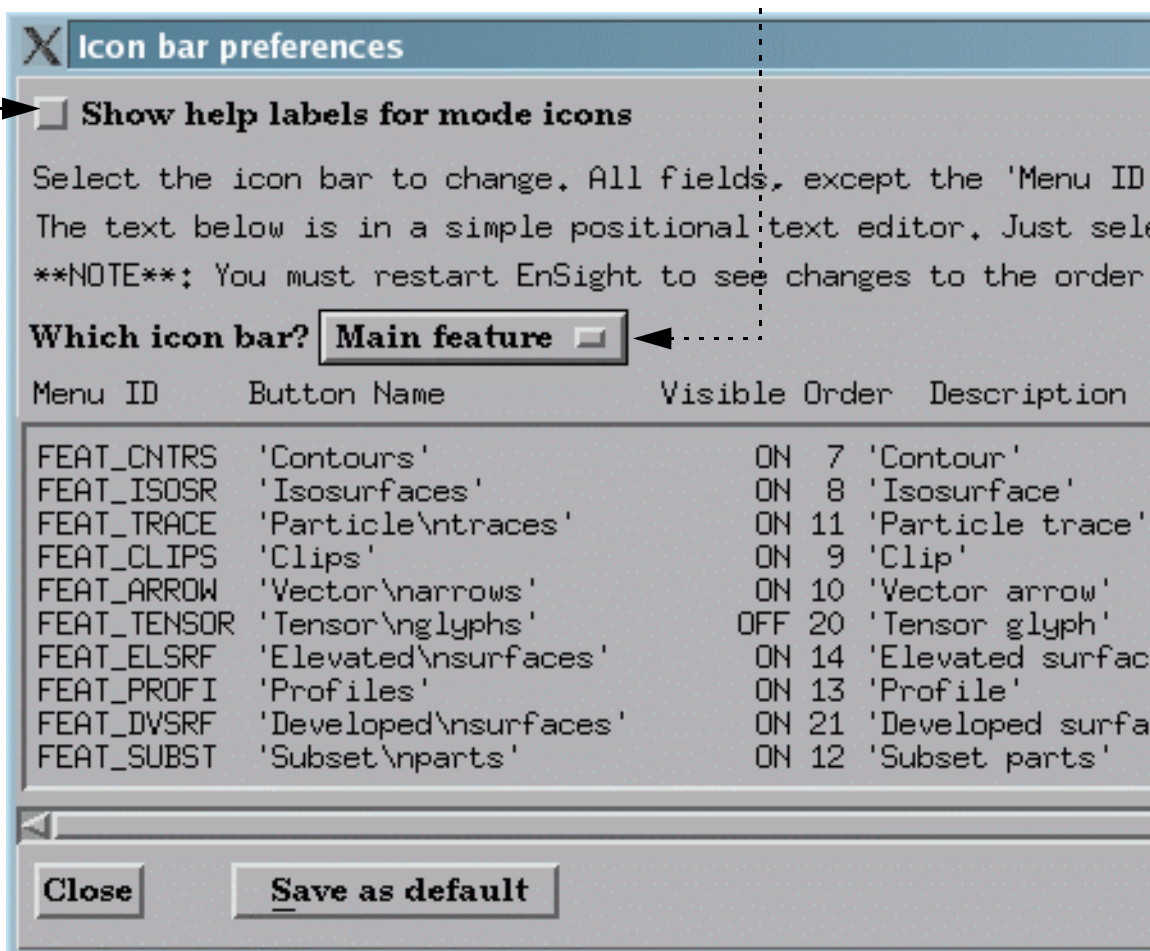

3. To disable display of the icon help labels, toggle off the **Show Help Labels For Mode Icons** button. (Off by default)

To edit, click the left mouse button at the desired location and change the text. Each entry in the list controls one icon and has the following components:

Menu ID	Internal ID. (Included for potential future usage – do not change).
Button Name	The name of the icon. (Included for potential future usage – do not change)
Visible status	Either ON or OFF.
Order	Icon order within the bar.
Description	Description printed in the Message Area when the left mouse button is clicked and held on the icon.

Note that changes will not take effect until the next time you run EnSight. To save your changes, click the **Save As Default** button and then click **Close**. To exit the dialog without saving your changes, just click **Close**.





ADVANCED USAGE

The lists presented in the Icon Bar Preferences dialog are stored on disk as text files in the `.ensight8/` directory (which is located in your home directory). If you prefer, you can edit these files directly with any text editor and the changes will take effect during your next EnSight session. The files are named as follows:

Main Feature	<code>ensight_feat_panel.def</code>
View	<code>ensight_view_panel.def</code>
Part	<code>ensight_part_panel.def</code>
Annot	<code>ensight_annot_panel.def</code>
Plot	<code>ensight_plot_panel.def</code>
VPort	<code>ensight_viewp_panel.def</code>
Frame	<code>ensight_frame_panel.def</code>

SEE ALSO

User Manual: [Icon Bars](#)

INTRODUCTION

When the mouse pointer is in the Graphics Window, clicking and holding the left mouse button as you drag will perform the current transformation (e.g. rotate or zoom) as selected in the Transformation Control area. To perform a different transformation, you have to move the mouse to the Transformation Control area, select the new operation, and move back to the Graphics Window. To avoid this, you can redefine how the left mouse works as well as map additional transformation operations onto the middle and right mouse buttons, combinations of mouse buttons, and double-clicking of mouse buttons.

This customization only effects the mouse usage while in the Graphics Window. The left button is still used for other user-interface actions.

BASIC OPERATION

To change the behavior of mouse buttons in the Graphics Window:

1. Select **Edit > Preferences...**, then click on **Mouse and Keyboard**

2. Set each mouse button pulldown (Left, Middle, Right and combinations of such) as desired (see below).

3. Set the double-click action for each mouse (see below).

4. Set the action for the keyboard 'P' key (see below).

5. Set desired Zoom Style.

Automatic slide will zoom based on the direction and distance the mouse is moved. To the right or up zooms away, while to the left or down zooms towards. The distance the mouse is dragged determines the rate of continuous zoom.

Manual drag zooms in the same directions, but only a distance relative to the distance the mouse is dragged.

6. Click **Save To Preference File** to save your changes (if you want these changes to be the default for future sessions of EnSight) and **Close** to exit the dialog.

The new settings will take effect as soon as you hit the close button. If you clicked Save To Preference Files, your changes are also written to a file and automatically loaded during future EnSight sessions.

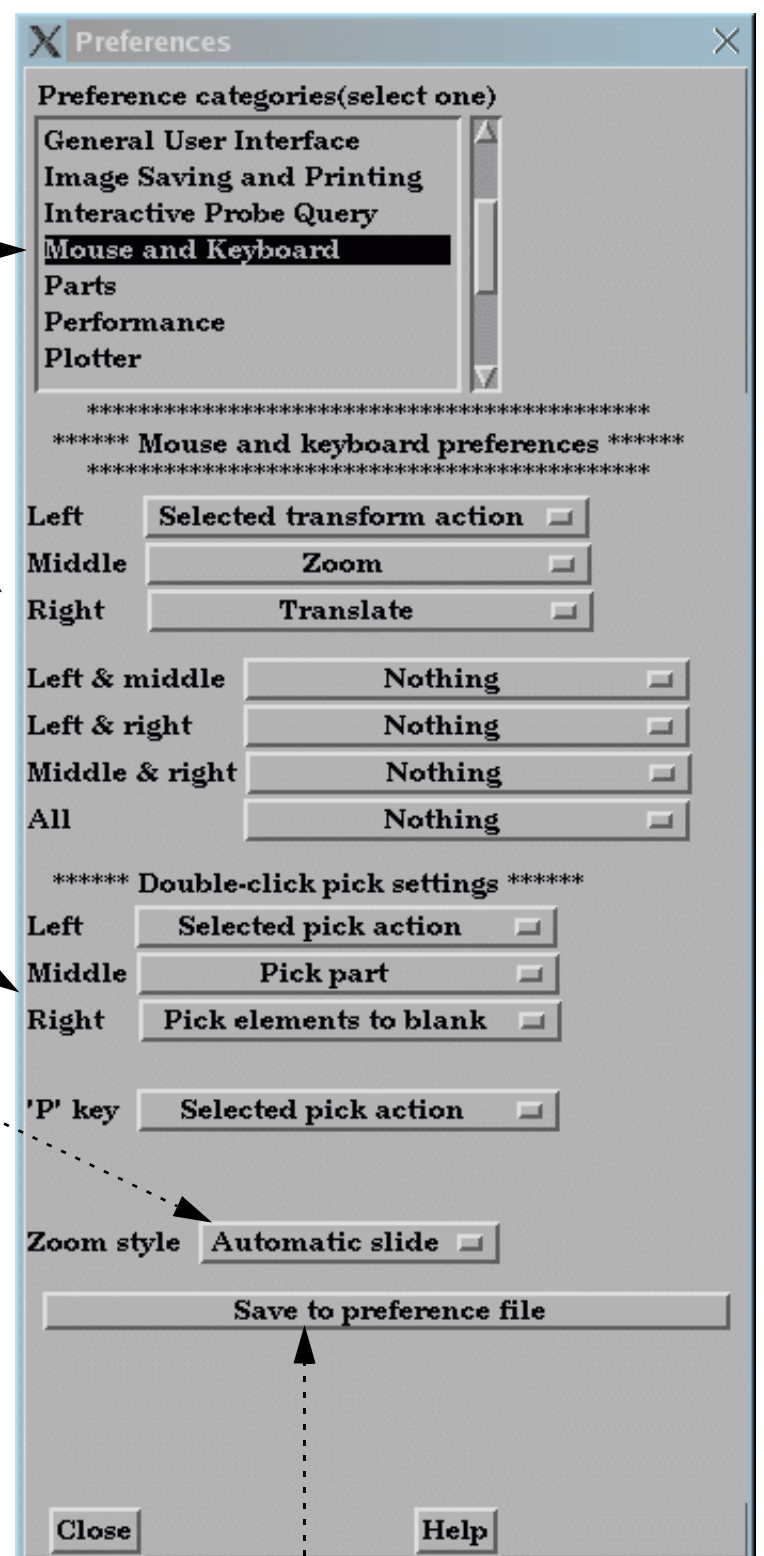



Each mouse button (or combination of mouse buttons) can have one of the following associated behaviors:

<i>Selected transform action</i>	When this mouse button is clicked and dragged, the operation performed will be the currently selected function in the Transformation Control area.
<i>Rotate</i>	When this mouse button is clicked and dragged, the operation performed will be rotate.
<i>Translate</i>	When this mouse button is clicked and dragged, the operation performed will be translate.
<i>Zoom</i>	When this mouse button is clicked and dragged, if Zoom Style is Manual Drag then a zoom displacement will occur, and if Zoom Style is Automatic Slide then a zoom velocity will occur
<i>Rubberband zoom</i>	When this mouse button is clicked and dragged, the operation performed will be a rubberband zoom.
<i>Rubberband selection tool</i>	When this mouse button is clicked and dragged, the operation performed will be a rubberband selection tool manipulation.
<i>Selected pick action</i>	When this mouse button is clicked, the currently selected pick action (as previously selected under the pick icon) will be performed.
<i>Pick part</i>	When this mouse button is clicked, the pick part action will be performed - causing the part under the mouse to be selected in the main parts list.
<i>Pick cursor tool location</i>	When this mouse button is clicked, the pick cursor tool action will be performed - causing the cursor tool to move to the picked location.
<i>Pick transf. center</i>	When this mouse button is clicked, the pick transformation center action will be performed - causing the center of transformation to move to the picked location.
<i>Pick elements to blank</i>	When this mouse button is clicked, the element blanking action will be performed - causing the element under the mouse to be removed.
<i>Nothing</i>	When this mouse button is clicked, no action will be performed.

Note that at least one of the mouse buttons(or combinations) must be set to “Selected transform action”!

Each double-click mouse action or the keyboard ‘P’ key can be set to the following:

<i>Selected pick action</i>	When this mouse button is clicked, the currently selected pick action (as previously selected under the pick icon) will be performed.
<i>Pick part</i>	When this mouse button is clicked, the pick part action will be performed - causing the part under the mouse to be selected in the main parts list.
<i>Pick cursor tool location</i>	When this mouse button is clicked, the pick cursor tool action will be performed - causing the cursor tool to move to the picked location.
<i>Pick transf. center</i>	When this mouse button is clicked, the pick transformation center action will be performed - causing the center of transformation to move to the picked location.
<i>Pick elements to blank</i>	When this mouse button is clicked, the element blanking action will be performed - causing the element under the mouse to be removed.
<i>Nothing</i>	When this mouse button is clicked, no action will be performed.

Note that at least one of the mouse buttons, double-click options or the “P” key must be set to “Selected pick action”!

SEE ALSO

User Manual: [Mouse and Keyboard Preferences](#)



Save GUI Settings

INTRODUCTION

The default size and position of the EnSight user interface windows was chosen to try to minimize window overlap. Since some users may have different criteria for window placement, EnSight provides a method for saving this information.

BASIC OPERATION

You can move and resize windows using the standard window manager operations. Once you have positioned your windows as desired:

1. Select **Edit > Preferences...**, select **General User Interface** and click **Save Size and Position of Main Windows**.

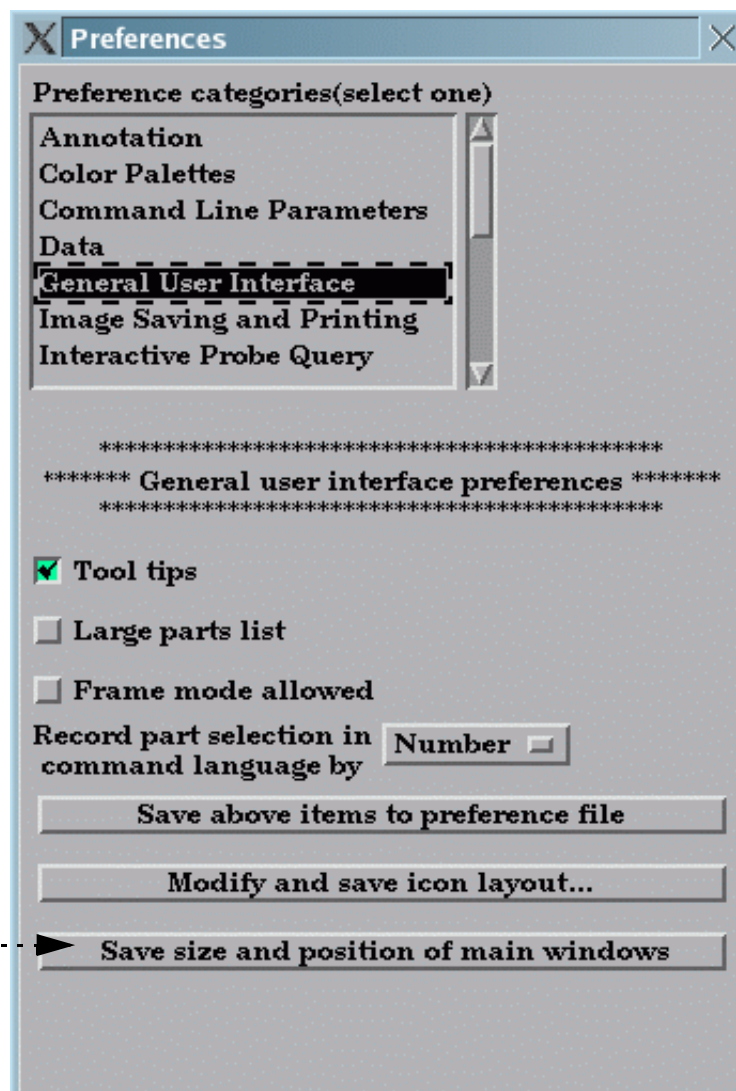

The information is saved in your `.ensight8/` directory (which is located in your home directory) in the file `ensight.winpos.default`.

This and many other preference settings can be set and saved, see [How To Set and Modify Preferences](#).

SEE ALSO

User Manual: [Save Window Positions](#) under the General User Interface of Prefs.



INTRODUCTION

Advanced users of EnSight often find themselves performing repetitive tasks. EnSight's macro facility lets you save a sequence of commands and then assign a keyboard key or mouse button to those commands such that they are executed when the key or button is pressed.

Pressing a key/button assigned to a macro causes the associated command file to be read and executed. Depending on how it is set up, a macro can execute it's file in one of three ways:

1. The command file is executed once for each key/button press. This mode is useful for one-time operations such as cutting flipbook animation on/off or saving an image.
2. The command file repeatedly executes as long as the key/button is held down. This is useful for operations that are continuous in nature, such as rotating around the Y axis by 5 degrees.
3. Multiple command files execute in a cycle for each keystroke or mouse button click.

Note: In the 8.0 release, EnSight uses a separate utility program (macromake) to create macros. In a subsequent release, this facility may be integrated into the user interface.

BASIC OPERATION

The first step in creating macros is to save the various command sequences that perform the desired actions. See [How To Record and Play Command Files](#) for more information. Be careful as you perform the operations that are saved to the command files. Superfluous or errant commands will slow down macro operation or cause errors. You may wish to view the resulting command files with a text editor and possibly make changes.

Once created, you should move the command files to your `~/ensight8/macros` directory. Although not required, it is useful to be able to distinguish these files from others – a common suffix such as `.mac` is often used.

Once the command files are ready, run the macro utility program, `macromake`. The executable is located in the `$CEI_HOME/bin` directory so it should already be in your command search path.

1. From a UNIX shell window, run macromake:

```
% macromake
```

The utility will print requests for action to the UNIX shell window. It also opens a graphics window (titled "Macromake") that is used to capture keyboard and mouse event codes. The basic macro definition process is as follows:

2. Specify the keyboard/mouse action by moving the mouse pointer into the Macromake window and pressing the desired keyboard key or mouse button. The Macromake window will close.

3. Respond to the questions in the UNIX shell window:

```
How many command files are
tied to this key?
```

Enter the number of command files that will execute (in turn) when the macro is executed.

```
Enter command file 1 to be
tied to this key:
```

Enter the name of the first command file to execute. If the response to the first question was greater than one, then enter each subsequent command file name (in the desired order of execution) when prompted.

```
Is this a repeatable macro?
```

Answer `y` for a repeatable macro (executes continuously as long as the key/button is depressed) or `n` for single execution.

```
Do you wish to define
another macro?
```

Answer `y` to define another macro or `n` to quit.

If EnSight is still running, you can click Reload Macros in the Command dialog (File > Command) to make your new macros active. Otherwise, they will be available during your next session of EnSight.



OTHER NOTES

The mapping from keys/buttons to command files is saved in the `macro.define` file. This file and associated macro command files are saved in your `~/.ensight8/macros` directory. Your local EnSight administrator can also define a common set of macros that are located in the `$CEI_HOME/ensight80/site_preferences/macros/` directory. These macros (if present) will be read first, followed by user-specific macros. User-specific key/button assignments therefore take precedence over site macros.

A common use of tying more than one command file to the same key is to create a toggle. Make the first command file turn the option on, and the second command file turn the option off. Then tie both of these to the same key. You will now cycle through the two command files, effectively creating a toggle situation.

SEE ALSO

[How To Record and Play Command Files](#)

User Manual: [Keyboard Macro Maker \(macromake\)](#)



INTRODUCTION

Nearly every operation and function in EnSight is initially set to a default value. Preferences allow you to set these initial values as well as set some default behaviors such as which time step to initially load for transient data, how the mouse buttons are defined, etc. When EnSight starts, the preference settings are read from the \$CEI_HOME/ensight80/site_preferences directory and then overlaid by the preference settings found in your .ensight8 directory.

BASIC OPERATION

1. Bring up the Preferences dialog by selecting Preferences from the Edit pull-down menu.

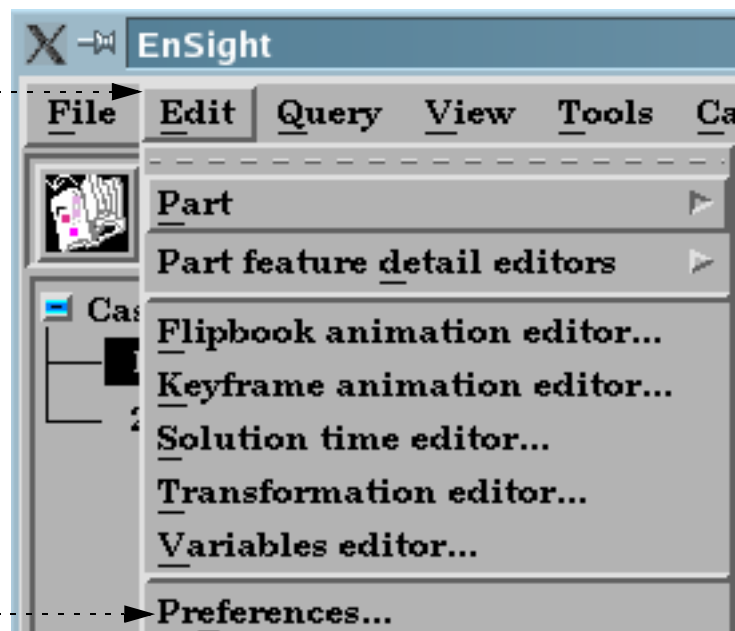

The following preference categories are available in the Preferences dialog (and will be explained below):

- To Set Annotation Preferences:
- To Set Color Palette Defaults:
- To Set Command Line Preferences:
- To Set Data Preferences:
- To Set General User Interface Preferences:
- To Set Image Saving and Printing Preferences:
- To Set Interactive Probe Query Preferences:
- To Set Mouse and Keyboard Preferences:
- To Set Part Preferences:
- To Set Performance Preferences:
- To Set Plotter Preferences:
- To Set Query Preferences:
- To Set User Defined Input Preferences:
- To Set Variable Preferences:
- To Set View Preferences:
- To Set Viewports Preferences:



To Set Annotation Preferences:

1. Select Annotation from the Preference Categories list.
2. Click the "Click Here To Start" button.
3. Click the Select button in the Annot mode icons and click Deselect All Annotations.
4. Set any attribute, for example line widths to 2 Pixels, text to left justification, etc.
5. You can also define any annotation (text, line, and logo) and have it be part of your preferences. Legends can also be part of the preferences, but these preferences are independent of the variable tied to the legend, i.e., the preference file keeps attributes for the first, second, third, etc. visible legends.
5. Click Save to Preference File to save the default annotation attributes. If you have defined any annotations, a pop-up will ask you if you want to save this annotation as part of your default or if your intent is to save the default attributes only.

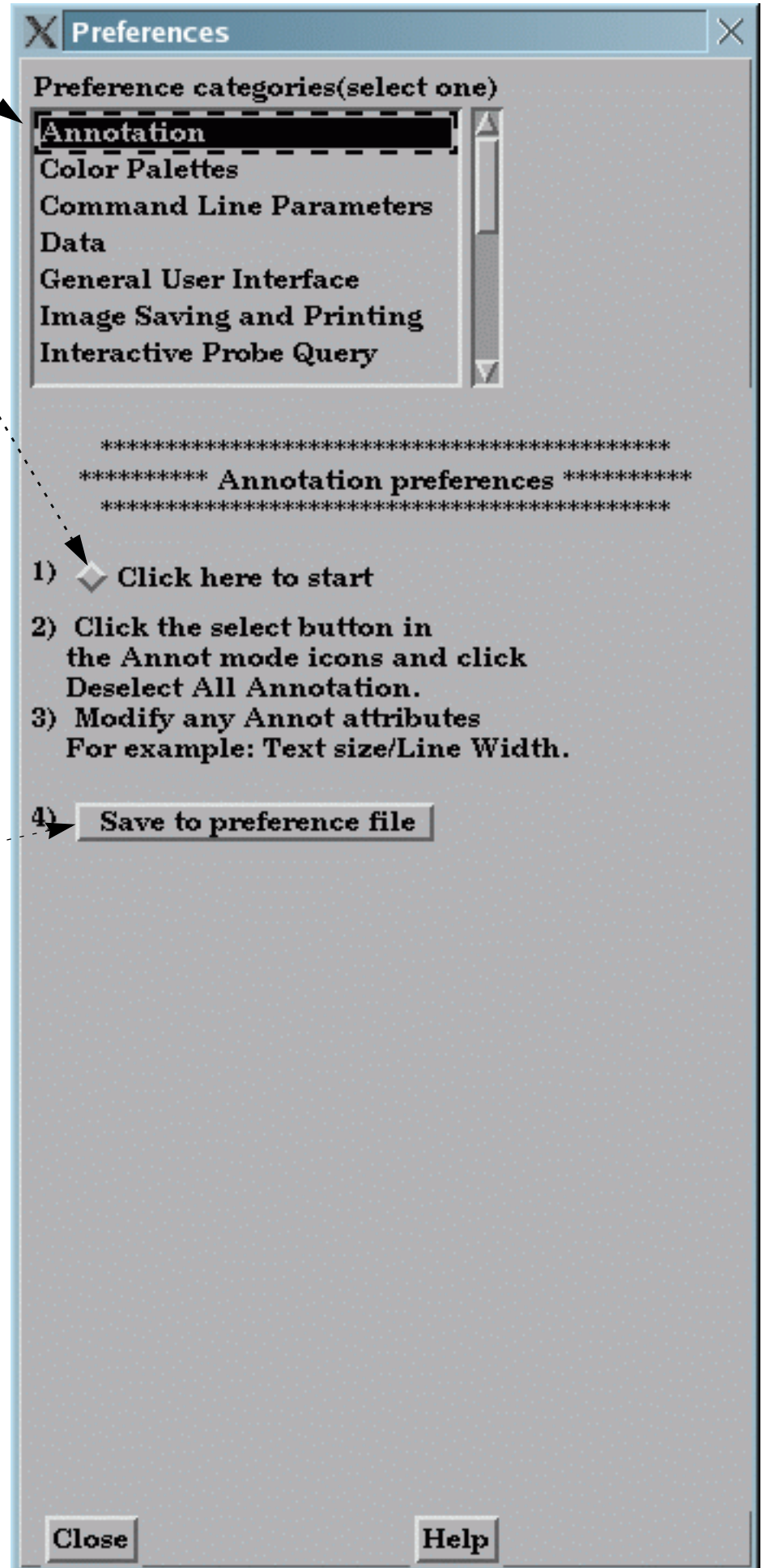



To Set Color Palette Defaults:

1. Select Color Palettes from the Preference Categories list.

2. Choose to color by RGB or Textures.

3. Toggle on if you want the color legend to automatically appear when you color a part by a variable.

4. Toggle on if you want color legends to be replaced when the current legend is no longer in use (i.e., no parts are colored by the variable) and a new variable is in use.

5. Toggle on if you wish the legend ranges to be updated when time is changed, thus based on values of variable at the current time.

6. Set the default legend for per element variables to be constant over the element or to vary continuously over the element (averages with neighbors).

7. Set the default legend editing interface to simple or advanced

8. If you have predefined color palettes, you can set one of them to be the default by entering the name or picking one from the list of defined palettes.

9. To set default legend attributes, click here. This will bring up the detail editor for color legends with no legends selected. In the feature detail editor, set the desired attributes such as linear/logarithmic scale, and continuous or banded type.

10. Click here to save the preferences.

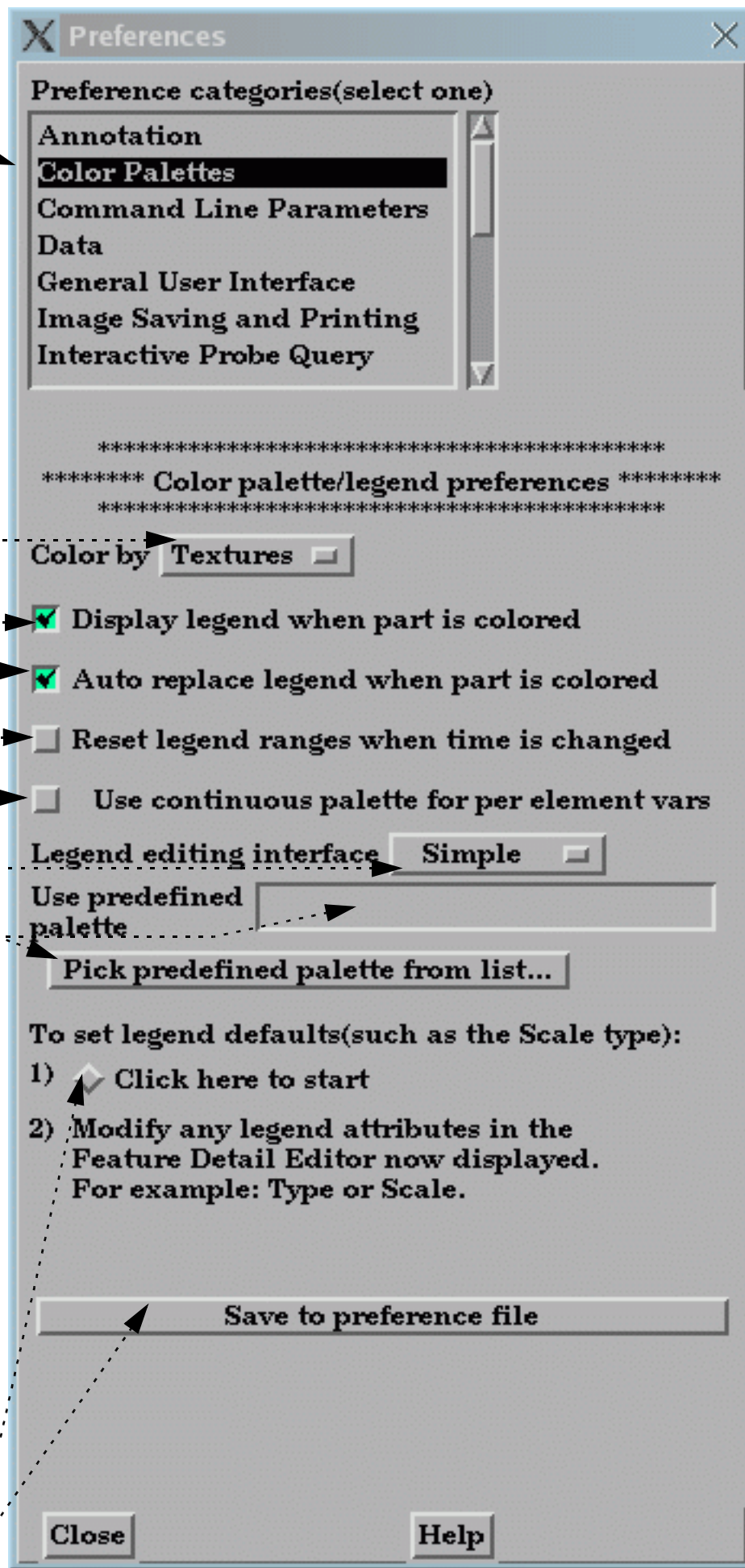



To Set Command Line Preferences:

A number of command line parameters exist for EnSight. These parameters can be set in your preference file so you do not have to specify them on the start line each time you use EnSight.

1. Select Command Line Parameters from the Preference Categories list.

2. Select a command line argument.

An explanation of the selected argument will appear in the dialog.

3. Click here to add the parameter.

It will be placed in the edit area.

If you make a mistake and add an unwanted parameter, simply highlight it in the feedback area and delete it.

If additional information is required, a note will be posted here to help you.

4. If you need to add additional information, add any text needed into the edit area.

5. Click here to save the preferences.

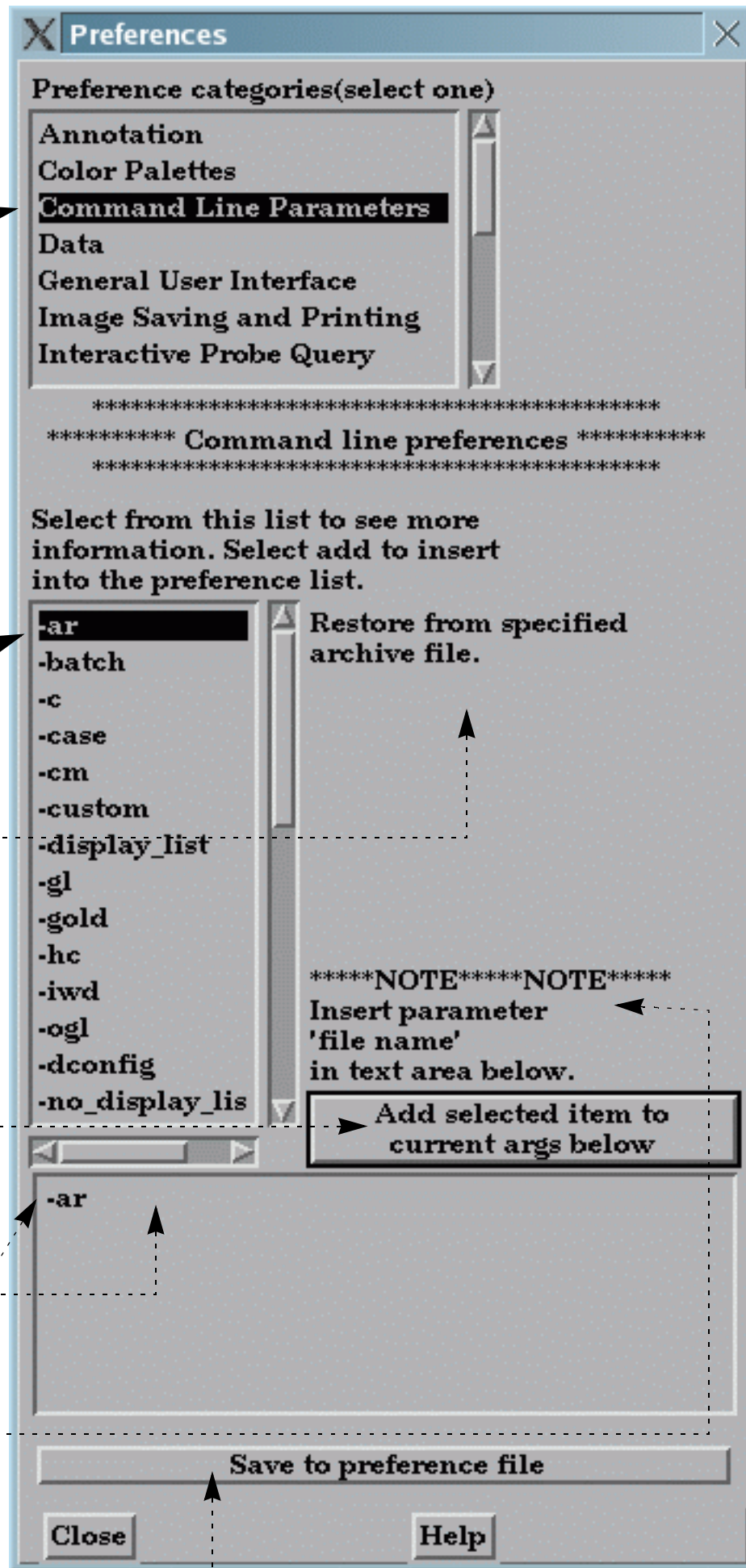



To Set Data Preferences:

1. Select Data from the Preference Categories list.

2. If you want to specify a path to look for data, specify it here.

3. You can specify the default binary file type here.

4. When transient data is loaded into EnSight you can choose to specify a beginning time step. If you do not specify a beginning time step, either the first or the last time step will be loaded depending on this preference.

5. After successfully reading data into EnSight you are presented (for most data formats) with a part loader if this attribute is set to No Parts. If set to any other attribute the parts specified will be loaded and displayed without intervention from the part loader.

Concerns periodic model updating while EnSight is running - Please Contact CEI Support regarding this option.

6. The readers shown with a * will show up in the pull-down for data format in the EnSight data reader dialog. You can take readers off of the pull-down list if you toggle the * off (select the reader in the list).

7. You can specify the default data type by typing in the exact name of the reader.

8. Click here to save the preferences.

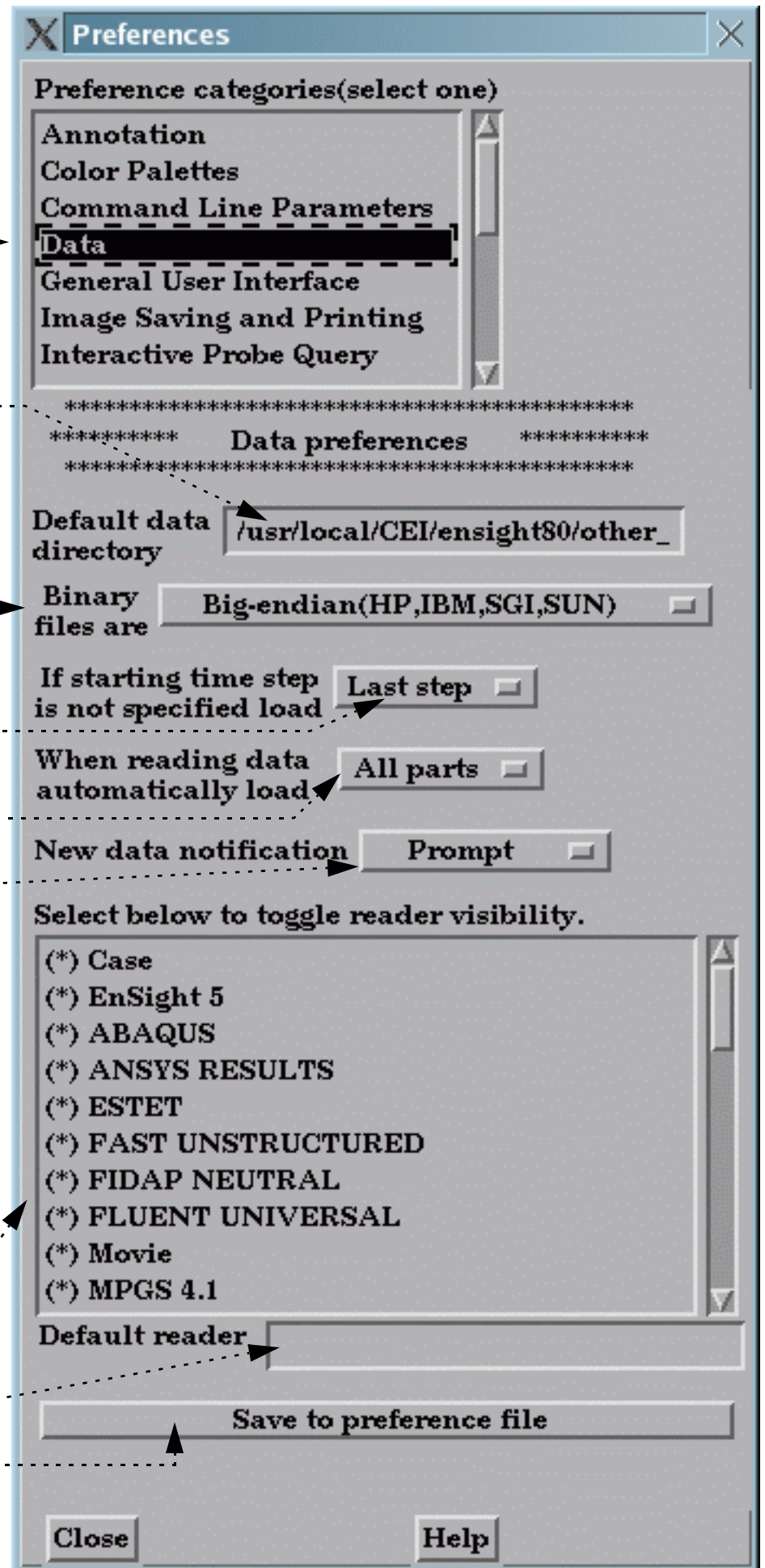



To Set General User Interface Preferences:

1. Select General User Interface from the Preference Categories list.

2. Toggle to show tool tips (balloon help).

3. Toggle to show long part list.

4. Toggle to show Frame mode as an available mode.

6. EnSight's command language records part names or numbers according to this choice. Recording by name is more portable for using the command language with a different dataset since the part numbers do not need to match up. However, recording by name produces slightly larger command files.

7. Click Save Above Items To Preference File to save the GUI items to your preference file.

8. To Modify EnSight's Icon Layout, click here.

9. To save as a preference the location and size of EnSight's windows, click here.

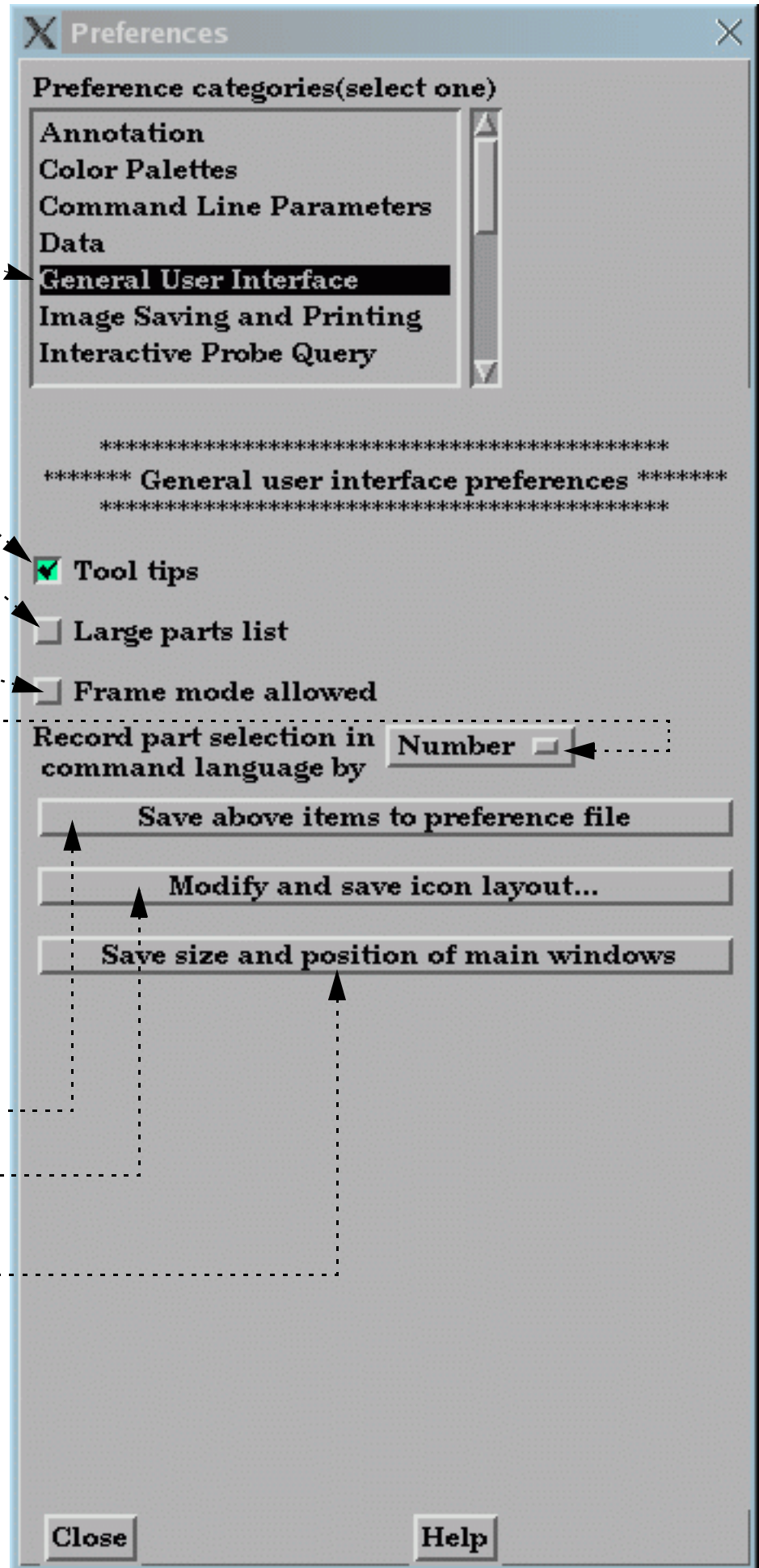

How To ... Set or Modify Preferences



To Set Image Saving and Printing Preferences:

1. Select Image Saving and Printing from the Preference Categories list.

2. Click the "Click Here To Start" button. This will bring up the Print/Save Image dialog.

3. Modify the attributes you want for your preference such as the image format.

4. Click here to save the preferences.

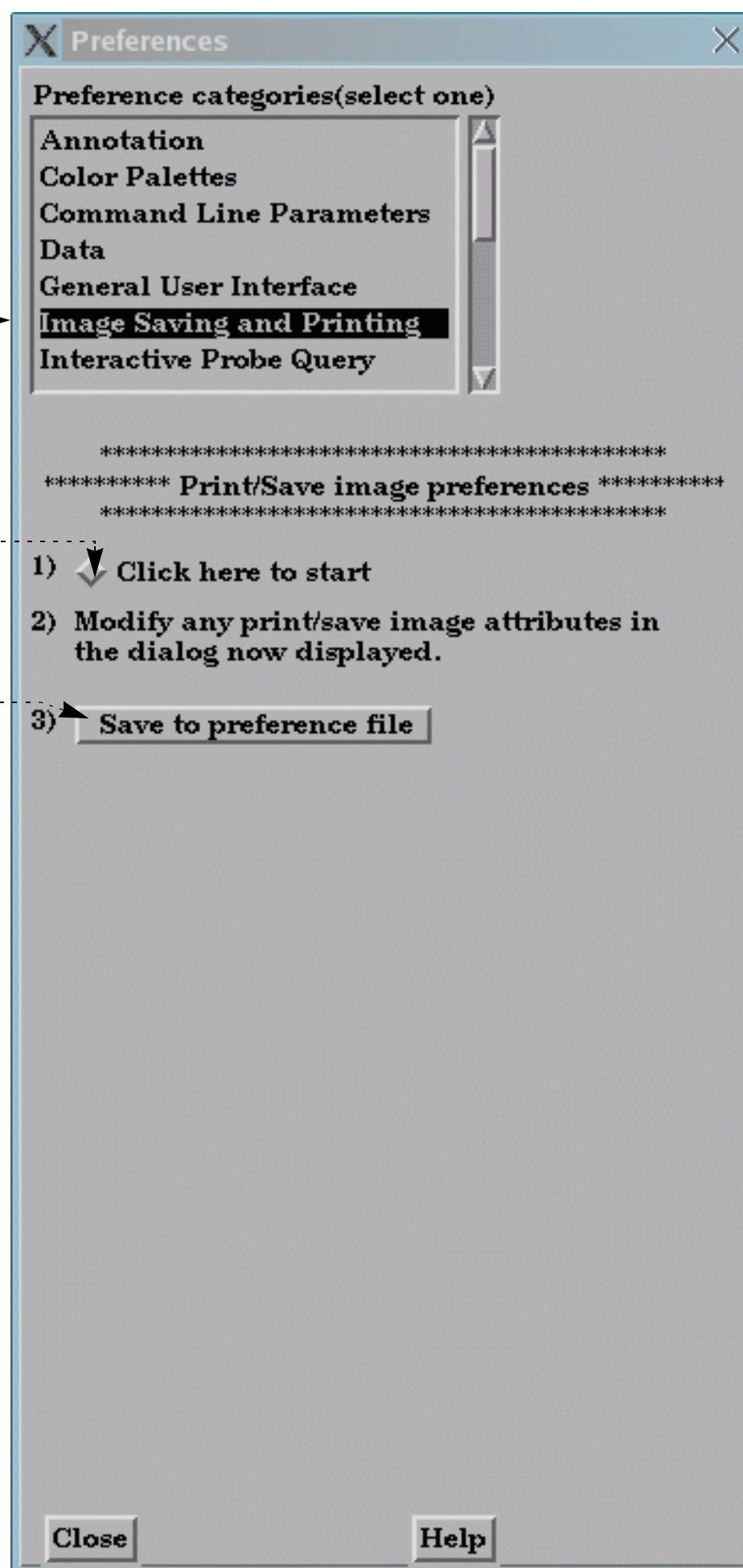



To Set Interactive Probe Query Preferences:

1. Select Interactive Probe Query from the Preference Categories list.

2. Click the "Click Here To Start" button. This will bring up Interactive Probe quick interaction area.

3. Modify the attributes you want for your preference such as Report By, and # Items Displayed.

4. Click here to save the preferences.

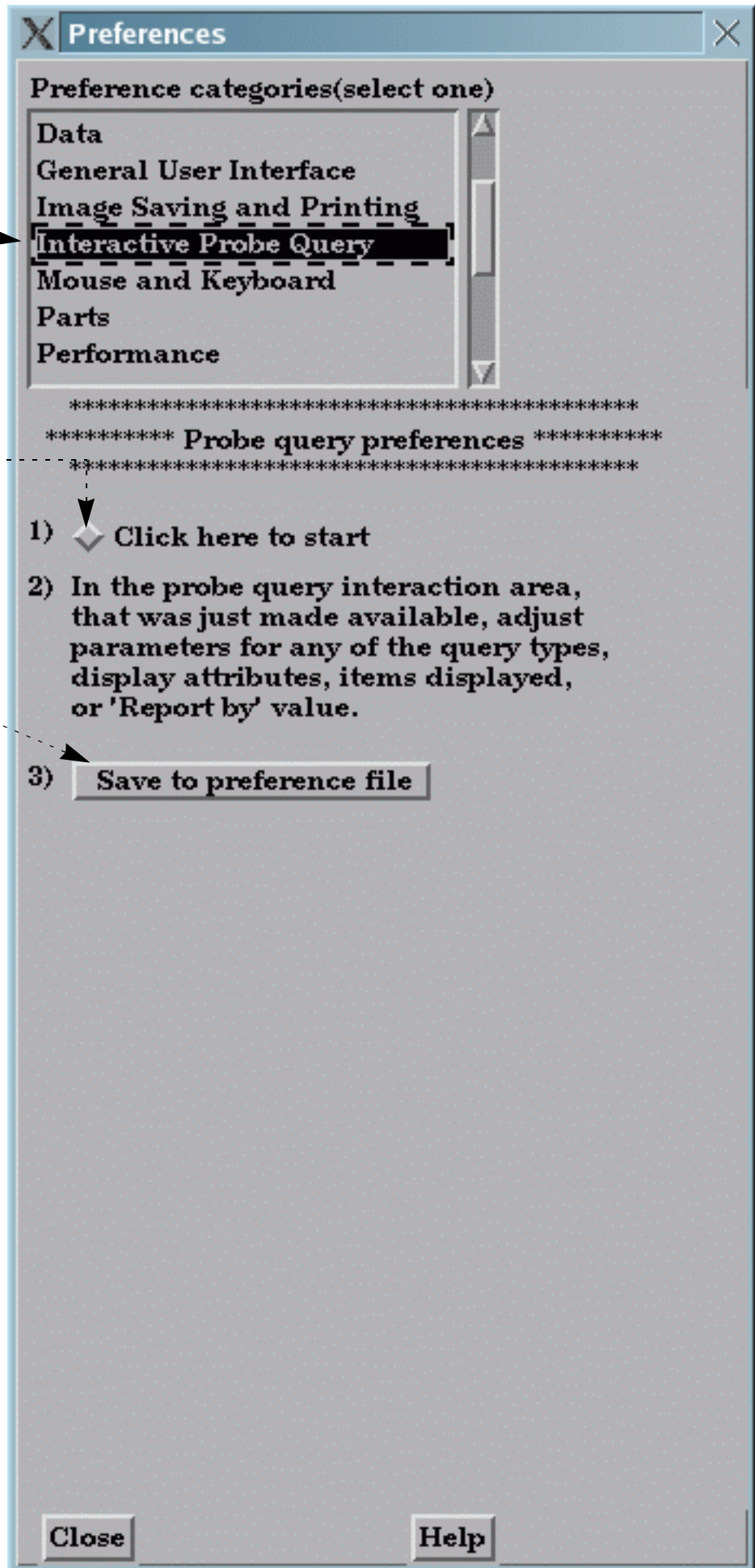



To Set Mouse and Keyboard Preferences:

This preference allows you to modify the behavior of the mouse buttons used during EnSight transformations. Several different actions are available for the various single click, multiple-button single click, and double click options. Note, it is required to set at least one button to "Selected transform action" (which means that the button is set to the action as shown in transformation icons at the bottom of the EnSight dialog - set to rotate by default). Also, one mouse or the "p" keyboard key must be set to "Selected pick action".

1. Select Mouse and Keyboard from the Preference Categories list.
2. Modify the preference for each of the mouse buttons (and keyboard 'P' key).

Single click actions available are:

- Selected transform action
- Rotate
- Translate
- Zoom
- Rubberband zoom
- Rubberband selection tool
- Selected pick action
- Pick part
- Pick cursor tool location
- Pick transf. center
- Pick elements to blank
- Nothing

Double-click picking options are:

- Selected pick action
- Pick part
- Pick cursor tool location
- Pick transf. center
- Pick elements to blank
- Nothing

And the possible zoom styles are:

- Automatic slide
- Manual drag

3. Click here to save the preferences.

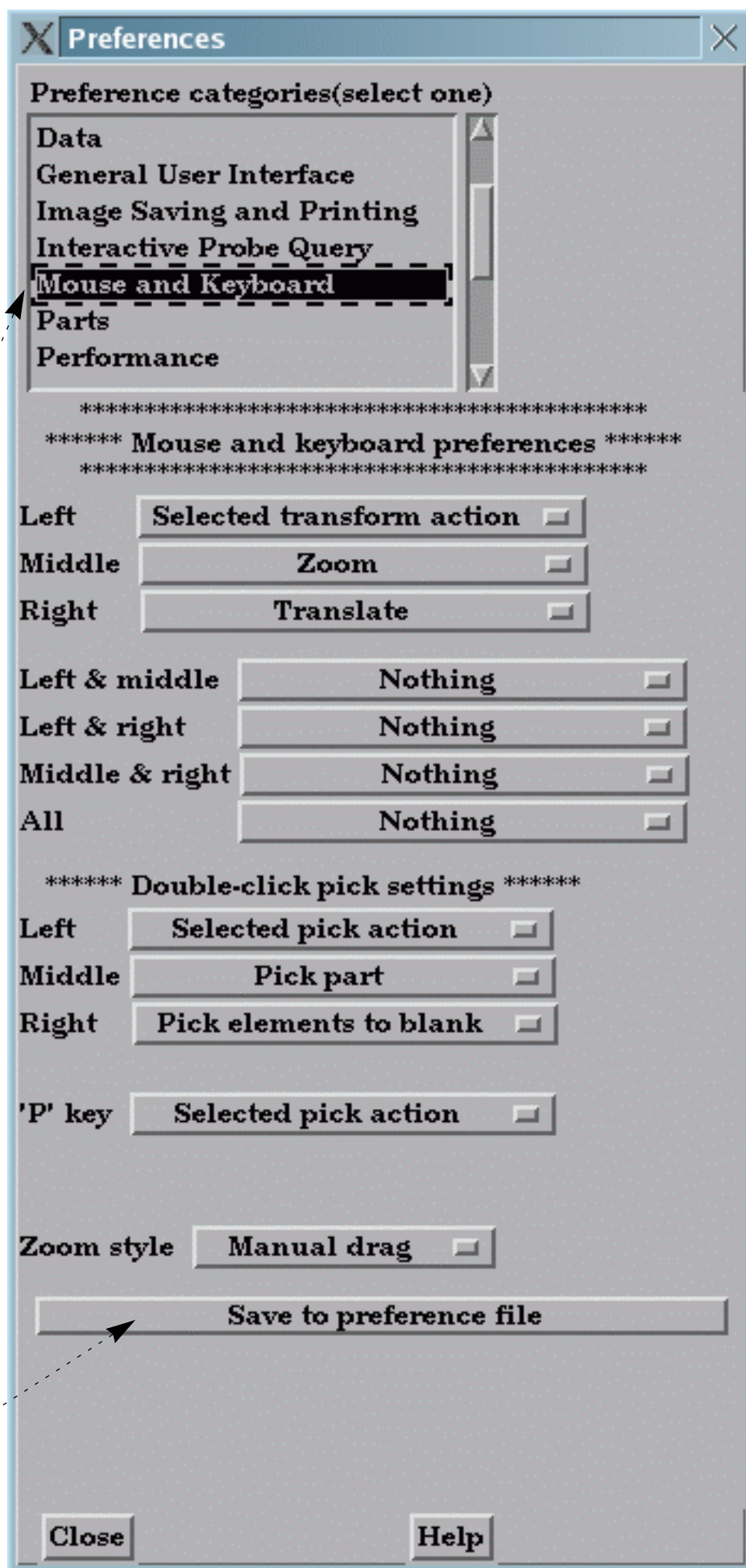



To Set Part Preferences:

1. Select Parts from the Preferences Categories list.
2. Click Allow editing part defaults if you want to be able to edit part defaults when no parts are selected.
3. Click the "Click Here To Start" button. This will bring up Part mode in EnSight and deselect any parts (so you can edit defaults).
4. Modify any part attribute such as line thickness.
5. Click Save General Part Preferences To File to save the default visual attributes for parts.
6. If you want to modify creation attributes for created parts, specify which dialog you want to use.
7. Set the part type.
8. Modify the attribute. For example, set subcontours to 3 for contour parts.
9. Click Save Preferences For Part Type Chosen To File to save the attributes for the part type edited.

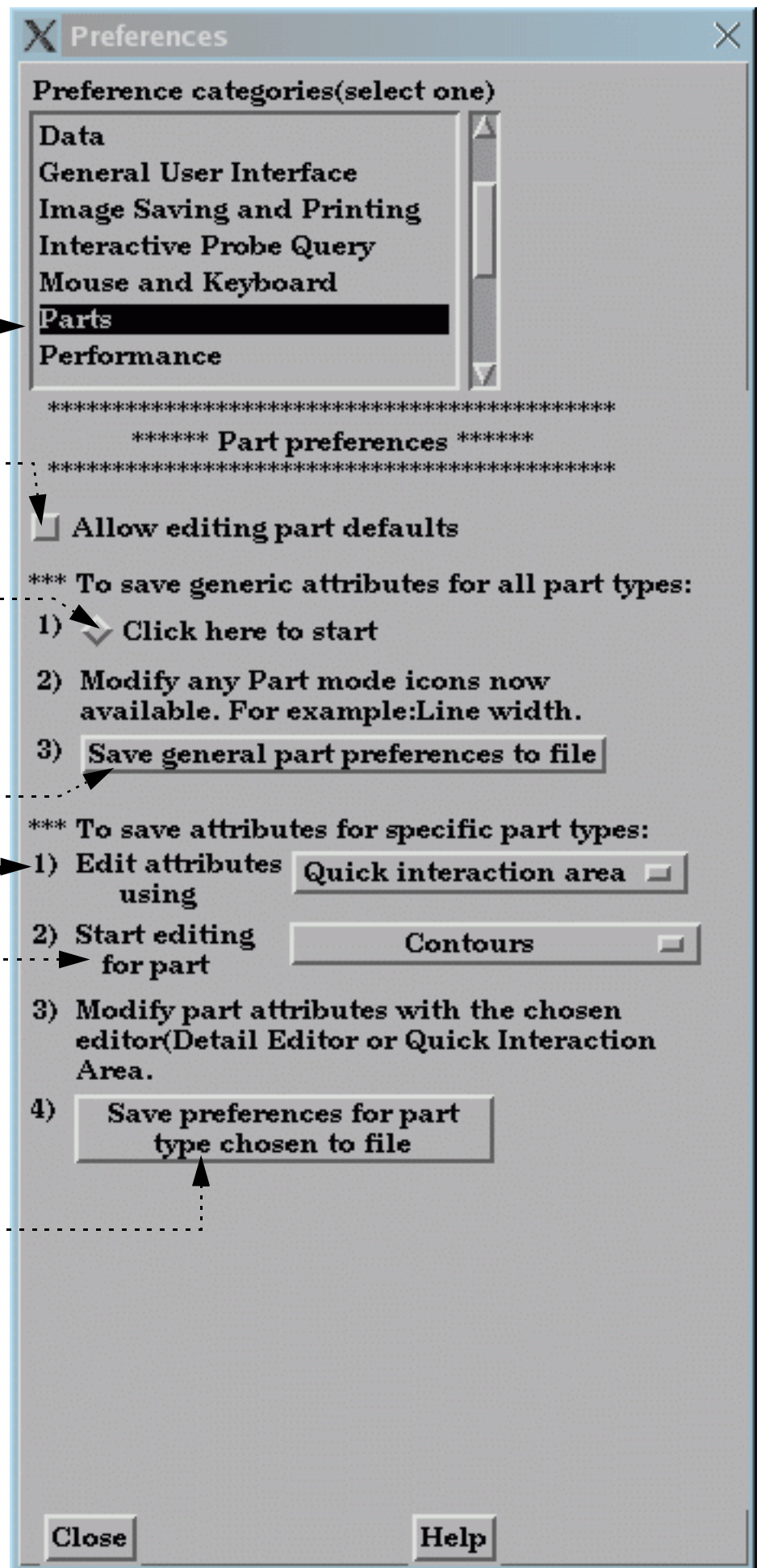



To Set Performance Preferences:

1. Select Performance from the Preferences Categories list.

2. To take advantage of pixel saving when redrawing a window movement, set this toggle. (Graphics card speed for reading/writing of pixels needs to be reasonable to use.)

2. To cull duplicate lines in-line drawing mode, set this toggle.

3. To set fast mode to static, toggle on. The default is off meaning that the fast display (i.e., bounding box) is only active during transformations such that the image returns back to full graphics display when the mouse buttons are not depressed. In static mode the fast representation is continuously displayed.

4. To sort the geometry during transformations, thereby creating correct transparent image at all times (but at a performance cost), set this toggle on. To delay the re-sort until the mouse is released, set this toggle off (better performance with often acceptable enough image)

4. If using point display for fast display mode, set the point resolution here.

5. If using sparse geometry display for fast display mode, set the percent of the model to show here.

(Only used if immediate mode is being used.)

6. Click here to save the preferences.

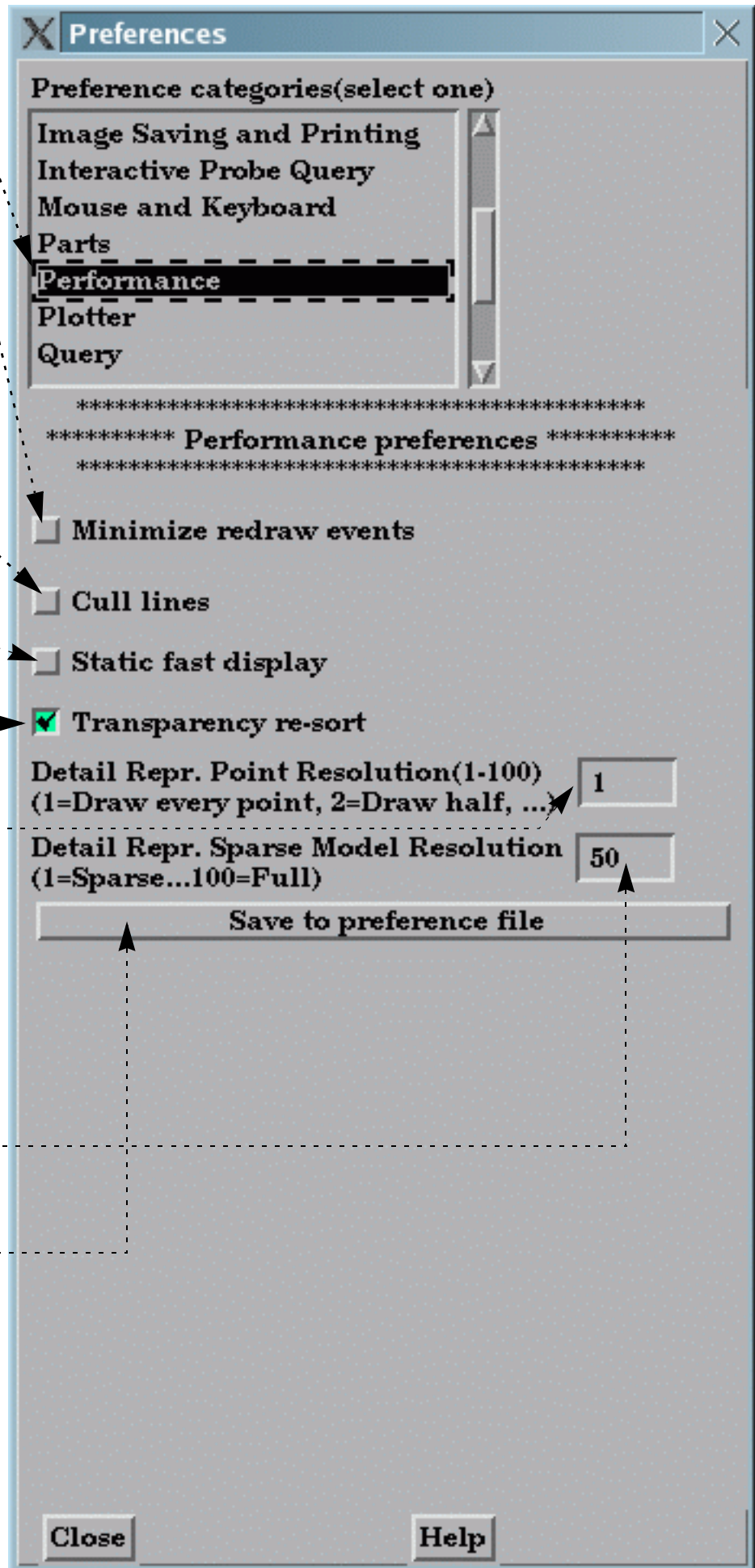



To Set Plotter Preferences:

1. Select Plotter from the Preferences Categories list.

2. Click the "Click Here To Start" button. This will bring up Plotter mode in EnSight and deselect any plots and curves.

3. Set any attribute, for example line width for curves, tick marks for axis, etc.

4. Click here to save the preferences.

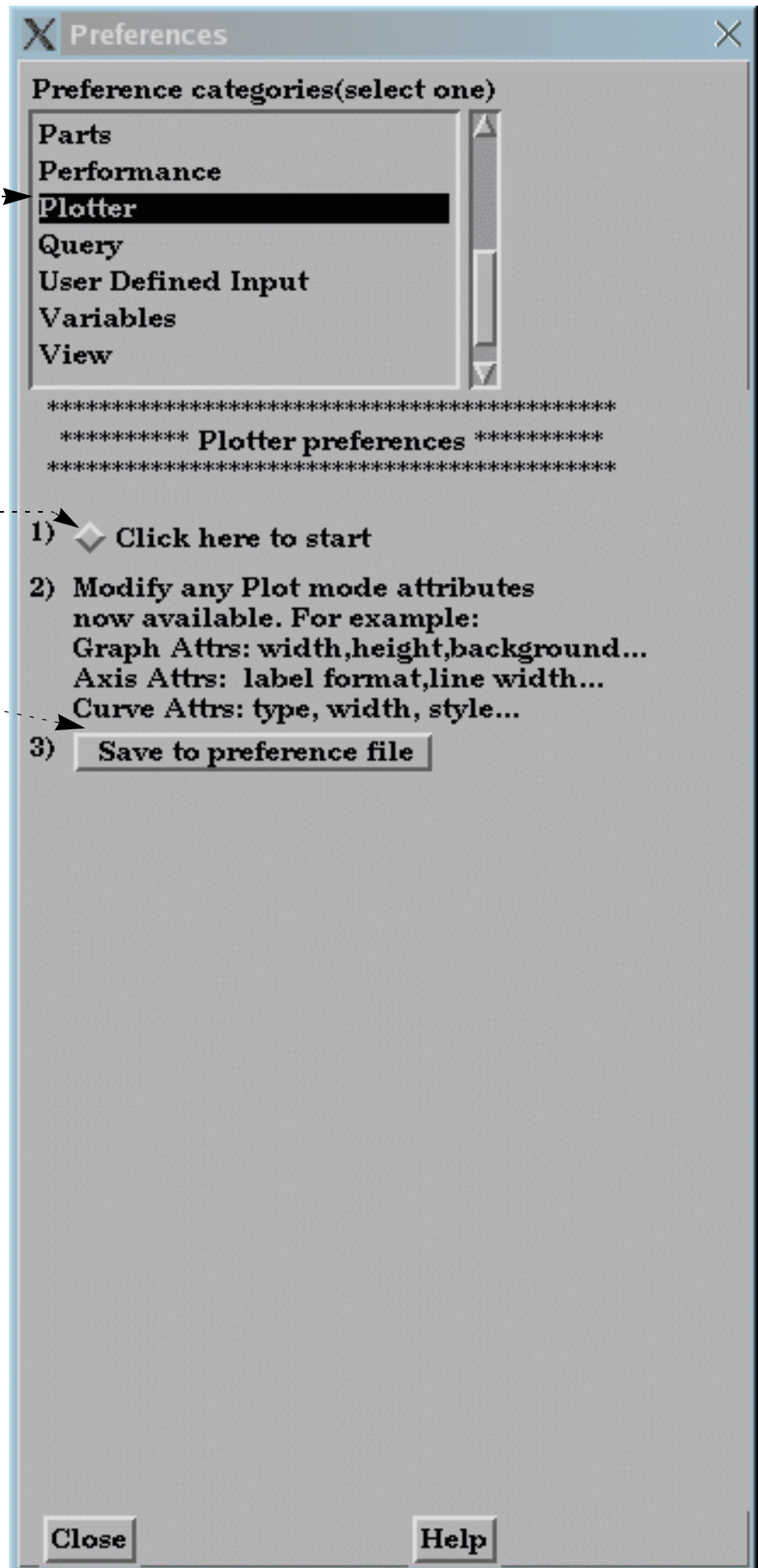



To Set Query Preferences:

1. Select Query from the Preferences Categories list.
2. Click this toggle on so that once you create a query it will be automatically plotted.
3. If Auto Plot Queries is toggled on, then you have the option to check this toggle. If on and an existing plot uses the same variables, you query will be added to this existing plot. Otherwise an new plot will be created.
4. Click the "Click Here To Start" button. This will bring up the Query quick interaction area with all query items deselected.
5. Set any attribute, for example Distance Type and 30 Samples for the Line tool constraint.
6. Click here to save the preferences.

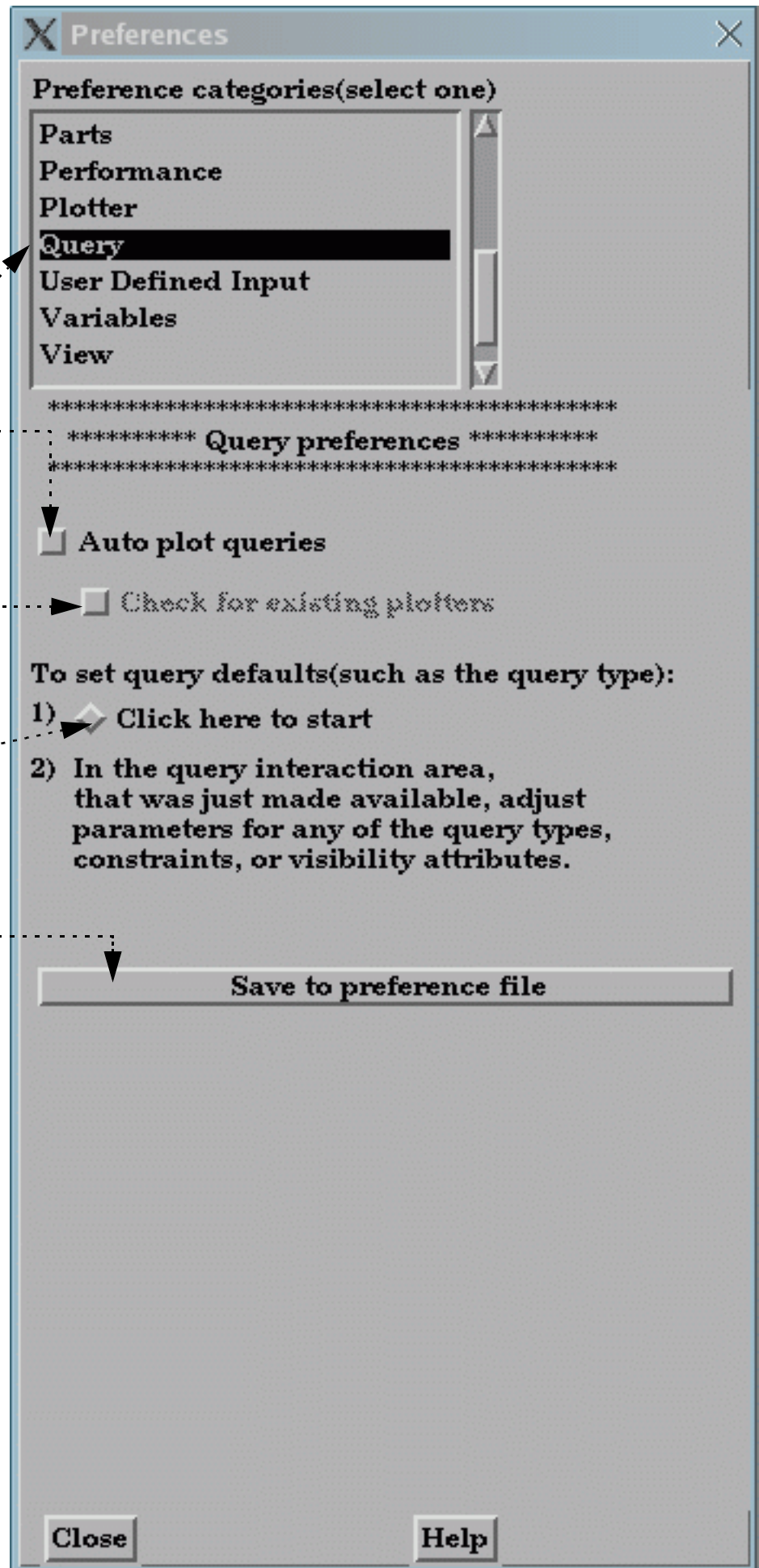



To Set User Defined Input Preferences:

1. Select User Defined Input from the Preferences Categories list.
2. Turn this on to show the macro panel display
3. Toggle to select the default to display a part list in the graphics window. This is especially helpful in full screen mode or a VR environment.
4. Turn this on to activate the user defined input device (ensight8_INPUT must be set to the proper device).
5. A Valuator can be used for zoom operations (like a virtual joy stick), or Position which simply means to delta movement in the Z direction will be used.
6. Sets the sensitivity for the zoom operation. The values for zoom are scaled by this setting, so values larger than 1.0 will make the inputs larger while less than 1.0 will make them smaller.
7. Mixed mode will use the input devices z rotate directly but use x and y translation values for x/y rotations. Direct mode will use the rotation angles from the input device directly for all three axis.
8. Sensitivity will set a scaling factor for the rotation values.
9. Click here to save the preferences.

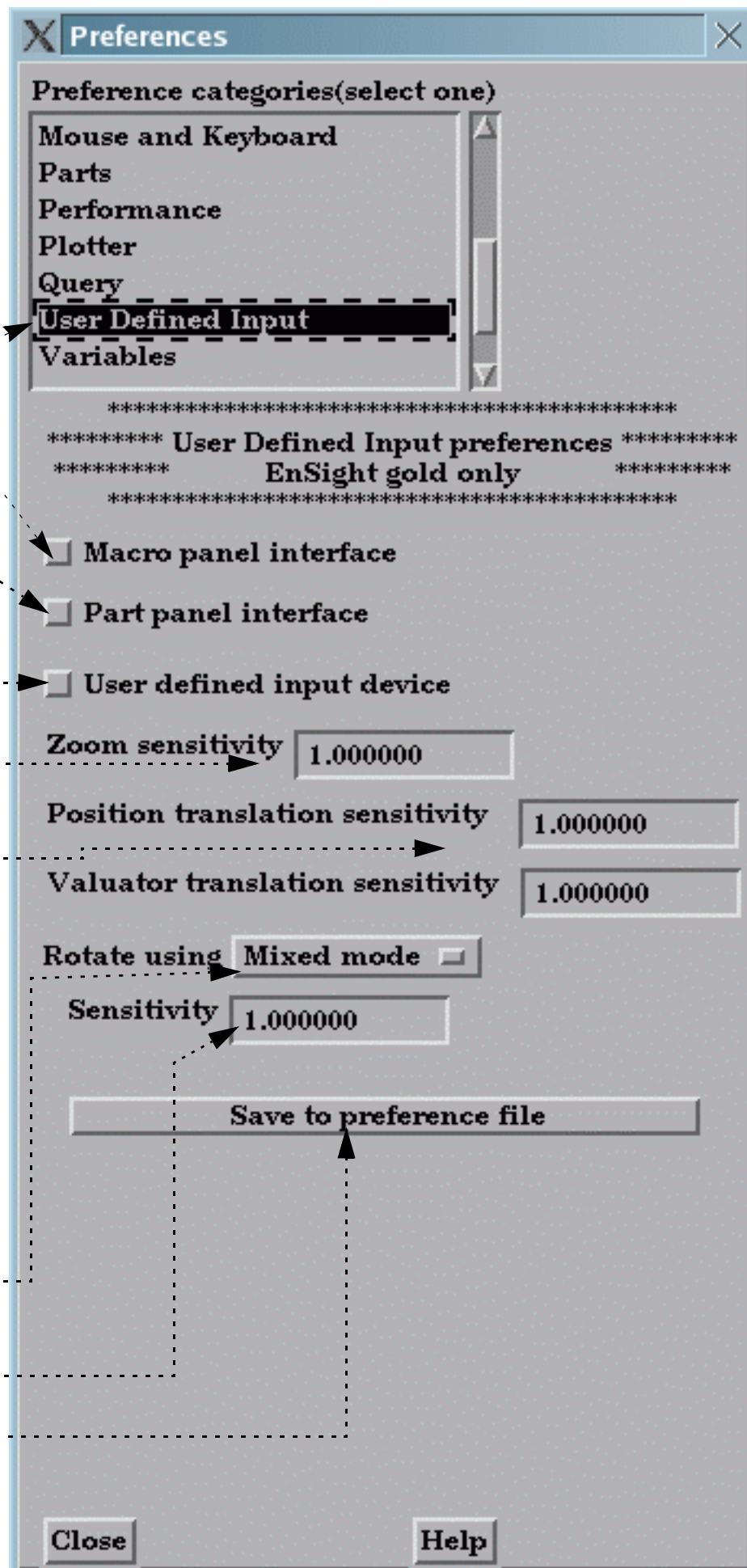



To Set Variable Preferences:

1. Select Variables from the Preferences Categories list.

2. Turn this on if you want to be notified before a variable is activated.

3. Toggle to select visibility of functions in the General Functions list of the New Variable Calculator dialog.

4. Save this notification request and function visibilities to the preference file by clicking here.

5. Brings up the dialog for setting extended CFD settings.

Save these settings by clicking here.

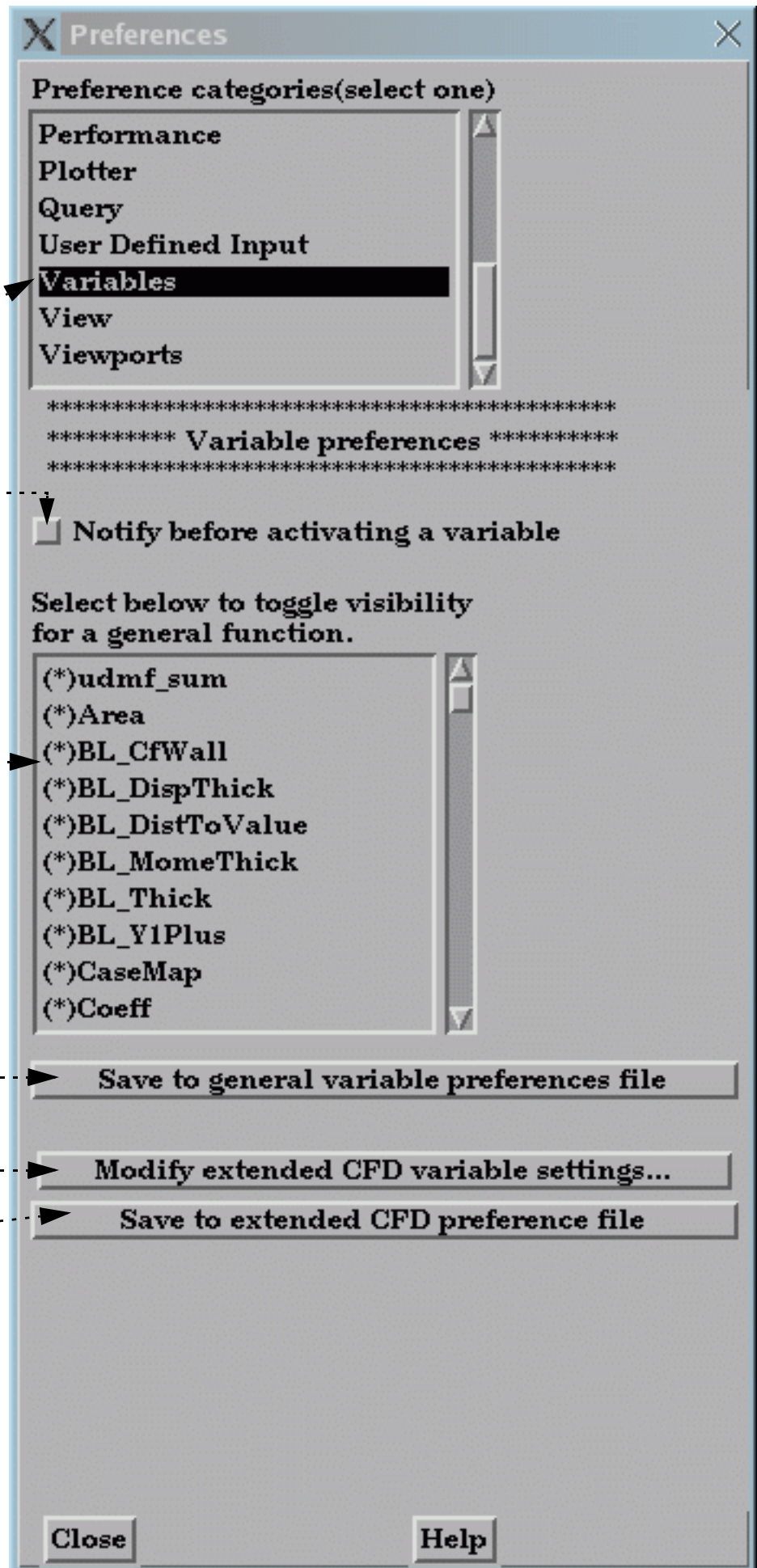

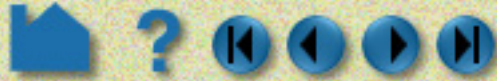

To Set View Preferences:

1. Select View from the Preferences Categories list.

2. Turn on if you want the plane tool to be shown as a transparent plane, or off if you want it shown in line drawing mode.

3. There are two offsets employed in EnSight. This one, hardware offset, is perpendicular to the monitor screen, and done in hardware if this toggle is on. This will allow, for example contour lines to appear closer to the viewer than their parent part so they are visible no matter what orientation the part is viewed from.

The second offset is the display offset. The display offset can be set in the feature detail editor for line parts such as contour lines, particle trace lines, vector arrows, and separation/attachment lines. The display offset is the distance in the direction of the element normal (perpendicular to the surface).

4. Select the default viewing orientation.

5. Pull down "View" menu and set items desired.

6. Click here to save the preferences.

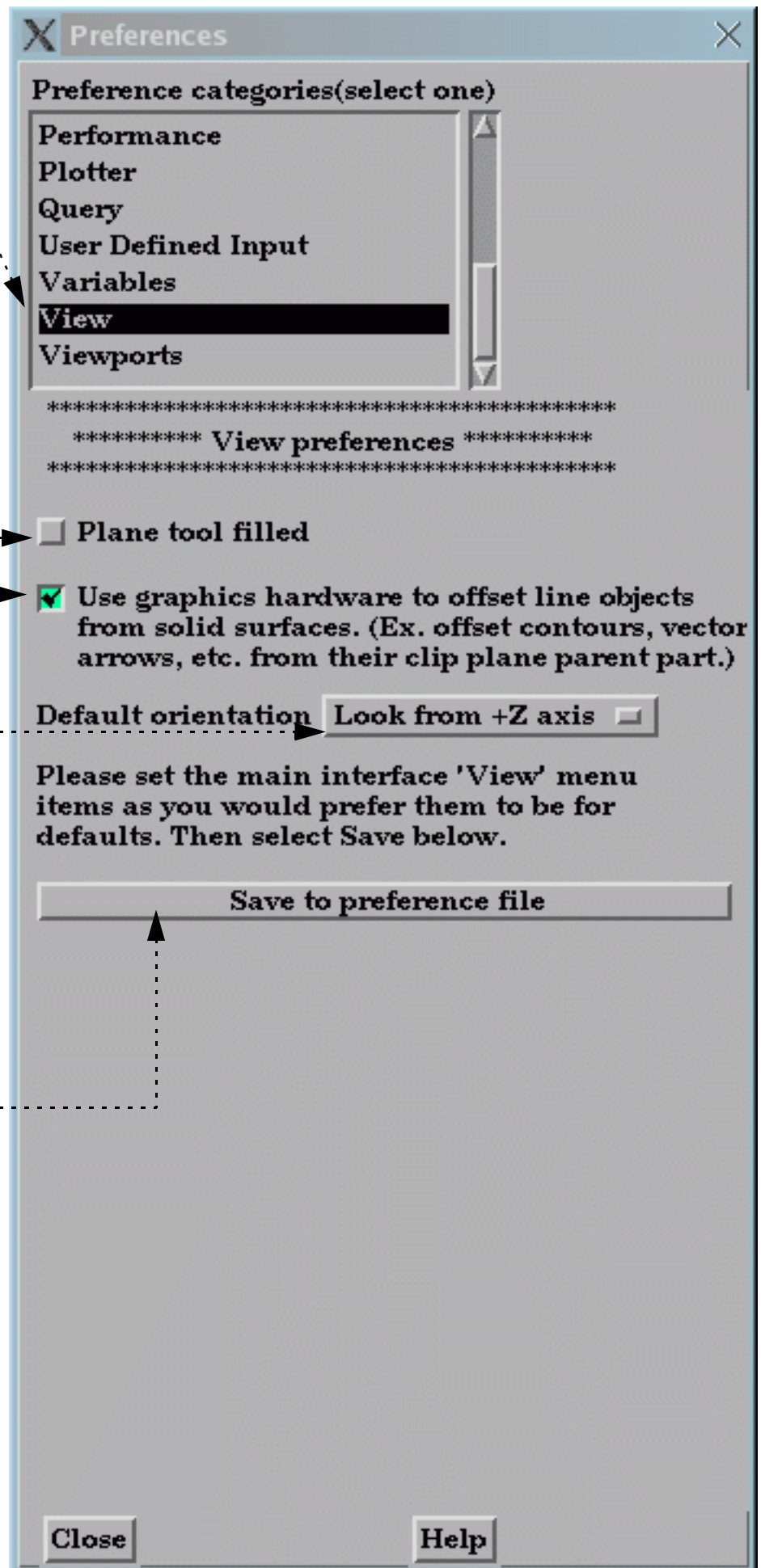



To Set Viewports Preferences:

1. Select the Viewports Category.
2. Click the Click Here To Start button.
This will bring up the Viewports quick interaction area with all viewport items selected.
3. Set any viewport attributes (for example, background color to blended).
4. Click here to save the attributes set in 2. to the preference file as defaults for future sessions.
5. Click her to save the current viewport layout to the preference file.

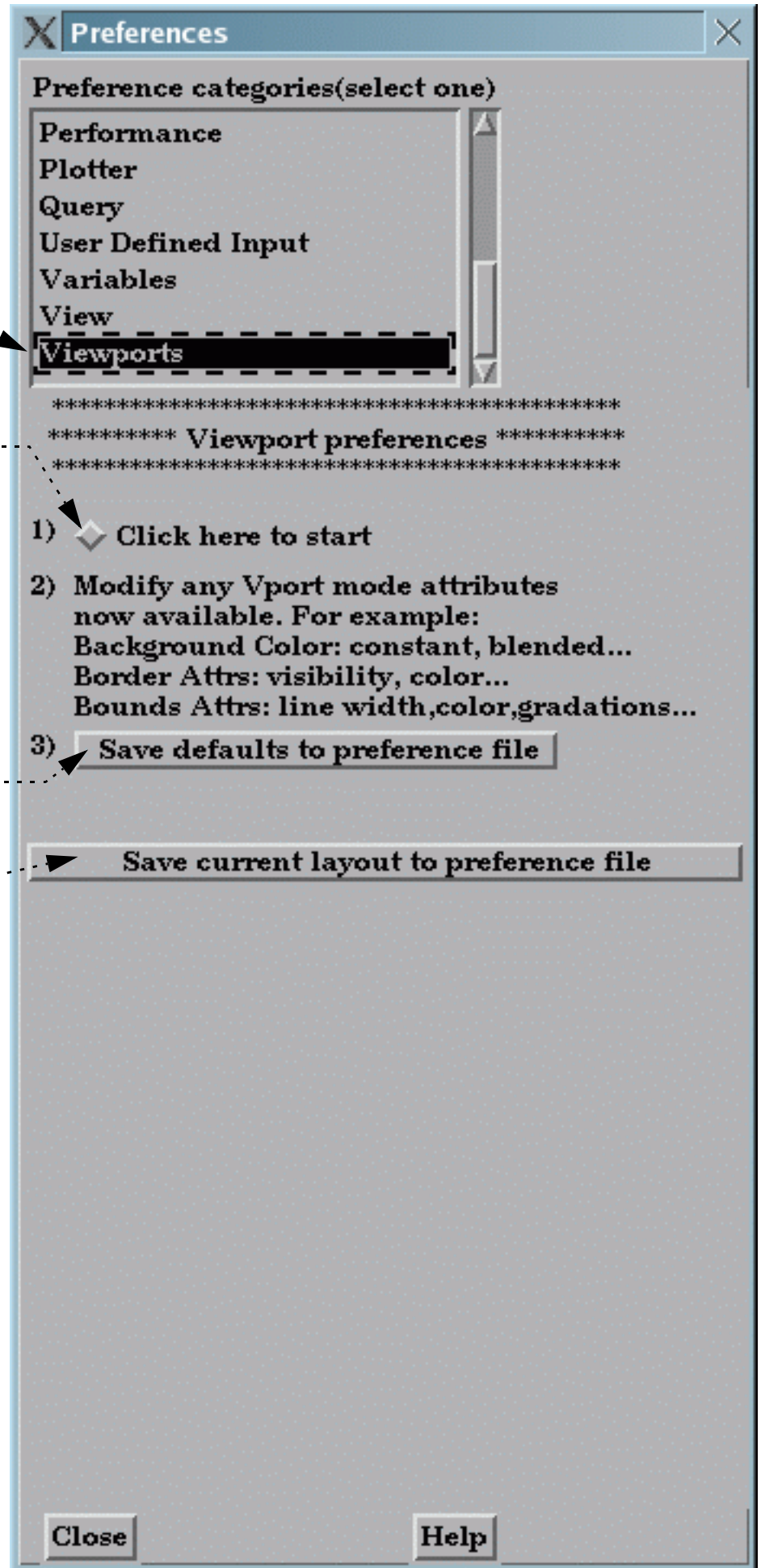

SEE ALSO

User Manual: [Edit Menu Functions](#)



Enable User Defined Input Devices

INTRODUCTION

EnSight offers user defined input devices that have been specifically designed for (but not limited to) typical input devices used in VR environments (such as the Immersadesk). Implementation of these input devices requires adherence to the instructions outlined in the respective reference files listed below.

BASIC OPERATION

Manual Panel Interface:

1. Select **Edit > Preferences...**, and click **User Defined Input**.

2. Toggle **Macro Panel Interface**.....

The Main Graphics window updates the Macro Panel as defined in the file:

```
~/ensight8/macros/hum.define
```

(If you have not created this file, an example is provided in:

```
$CEI_HOME/ensight80/src/input/HUM/hum.define
```

on your EnSight Client host system.)

3. Toggle **Part Panel Interface** (if you desire a part list in the graphics window).

4. Toggle **User Defined Input**.....

(Detailed steps to implement the User Defined Input Device are outlined in the file:

```
$CEI_HOME/ensight80/src/input/README
```

on your EnSight Client host system.)

5. Set **Zoom Using** to the appropriate type of input device you are using to record zoom transformations, adjusting the **Sensitivity** as needed (i.e., 0 < slower < 1 faster).

6. Set **Rotate Using** to the appropriate type of input device you are using to record rotation transformations, adjusting the **Sensitivity** as needed (i.e., 0 < slower < 1 faster).

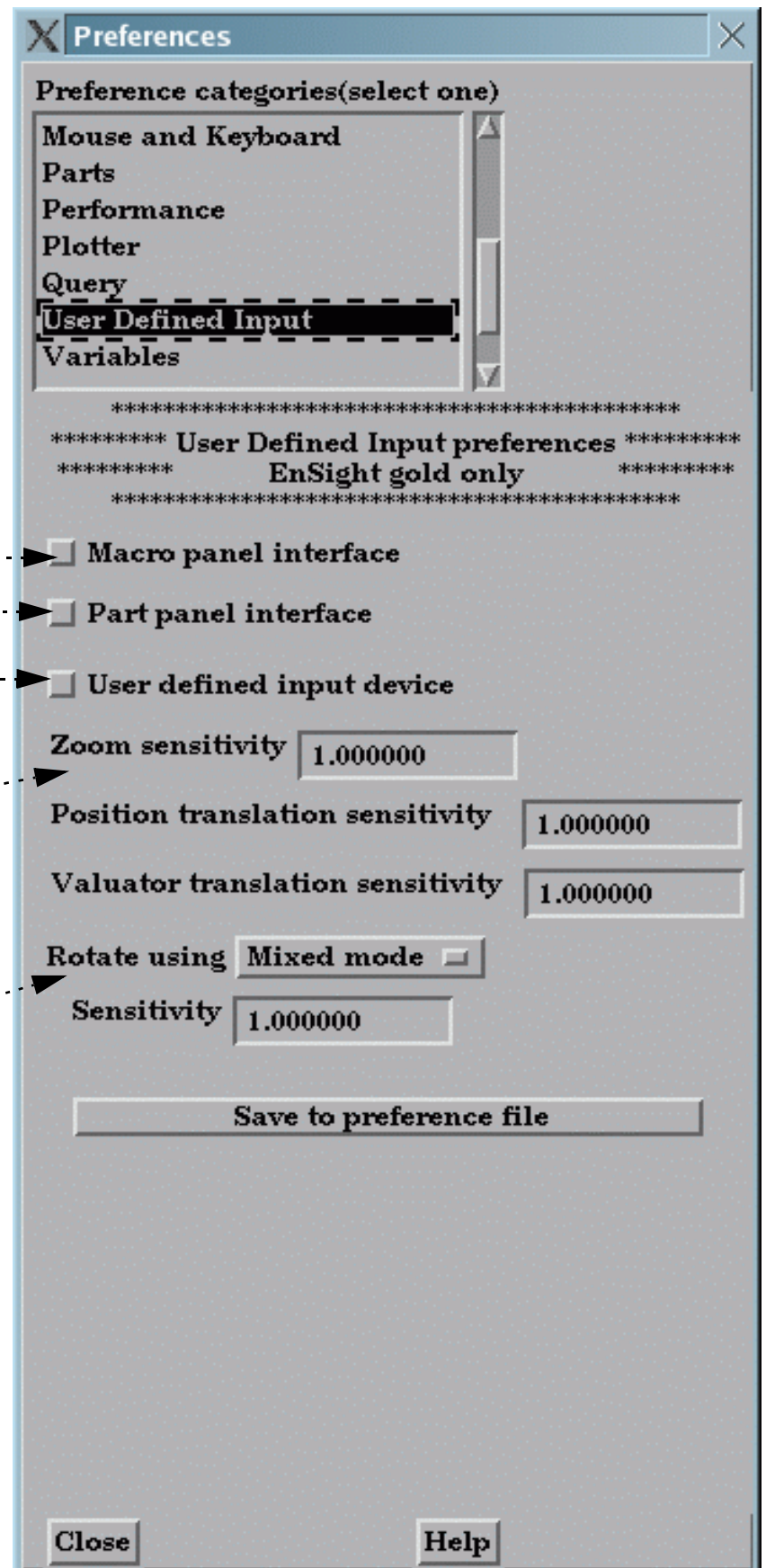

SEE ALSO

User Manual: [“User Defined Input Preferences”](#)



INTRODUCTION

EnSight supports shared-memory parallel computation via POSIX threads on all of our supported platforms.

BASIC OPERATION

Configuration

Each executable of EnSight can be configured individually to control the number of threads used. The following environment variables are used to specify the maximum number of threads that the executable should use for computation.

ENSIGHT8_MAX_THREADS

The maximum number of threads to use for each EnSight server. Threads are used to accelerate the computation of streamlines, clips, isosurfaces, and other compute-intensive operations.

ENSIGHT8_MAX_CTHREADS

The maximum number of threads to use for each EnSight client. Threads in the client are used to accelerate sorting of transparent surfaces.

ENSIGHT8_MAX_SOSTHREADS

The maximum number of threads to use for each EnSight server-of-servers. This variable is introduced for planned future use, but at the time of this writing no operations in the server-of-servers are accelerated with threads.

OTHER NOTES

The number of threads is limited to 2 (per client or server) with a Standard license, while the upper limit for a Gold license is 128. When setting these parameters it is a good idea to take into account the number of processors on the system. In general, you will not see benefit from setting the parameters higher than the number of total processors. Because the server, server-of-servers and client operate in a pipelined fashion, it is not necessary to limit one in order to apply more threads to another.

Compute intensive server operations that make use of shared memory parallel computations include isosurface, clipping, and particle trace computations. Client threaded operations include transparency resort and display list creation.



INTRODUCTION

EnSight Gold now supports general parallel rendering for increased performance, increased display resolution, and arbitrary screen orientations. The configuration file format and several examples are described in the User Manual. Just click the link below to see this information.

SEE ALSO

User Manual: [Parallel Rendering and Virtual Reality](#)



Miscellaneous
Select Files

INTRODUCTION

Many operations in EnSight (such as loading data) require that you specify a file. EnSight uses a standard file selection dialog that lets you quickly search through directories to find the desired file.

BASIC OPERATION

By default, the File Selection dialog opens with the directory from which the EnSight client was started as the current directory. When opened subsequently, the directory that was last selected will be current.

The following shows the basic components of the File Selection dialog:

The Filter displays the name of the current directory and controls the listing of files in the Files list. You can use standard wildcard characters (such as *) to restrict the list to only those file names that match the wildcard. See [Wildcarding](#) below for more information.

The Directories list displays all directories in the current directory. Note that the current directory is shown ending with "." and the parent of the current directory is shown ending with ".." (standard UNIX nomenclature). To open a directory, double-click it.

The Selection field contains the full path name of the file currently selected in the Files list. This is the file that will be chosen if Okay is clicked. **Change the selection either by clicking a file in the Files list or editing the field directly. Pressing return will accept the Selection and close the dialog.**

The Files list displays the list of files contained in the current directory (possibly modified by the wildcard in the Filter field). **To make a file the current Selection, click it. To accept a file and close the dialog, double-click it.**

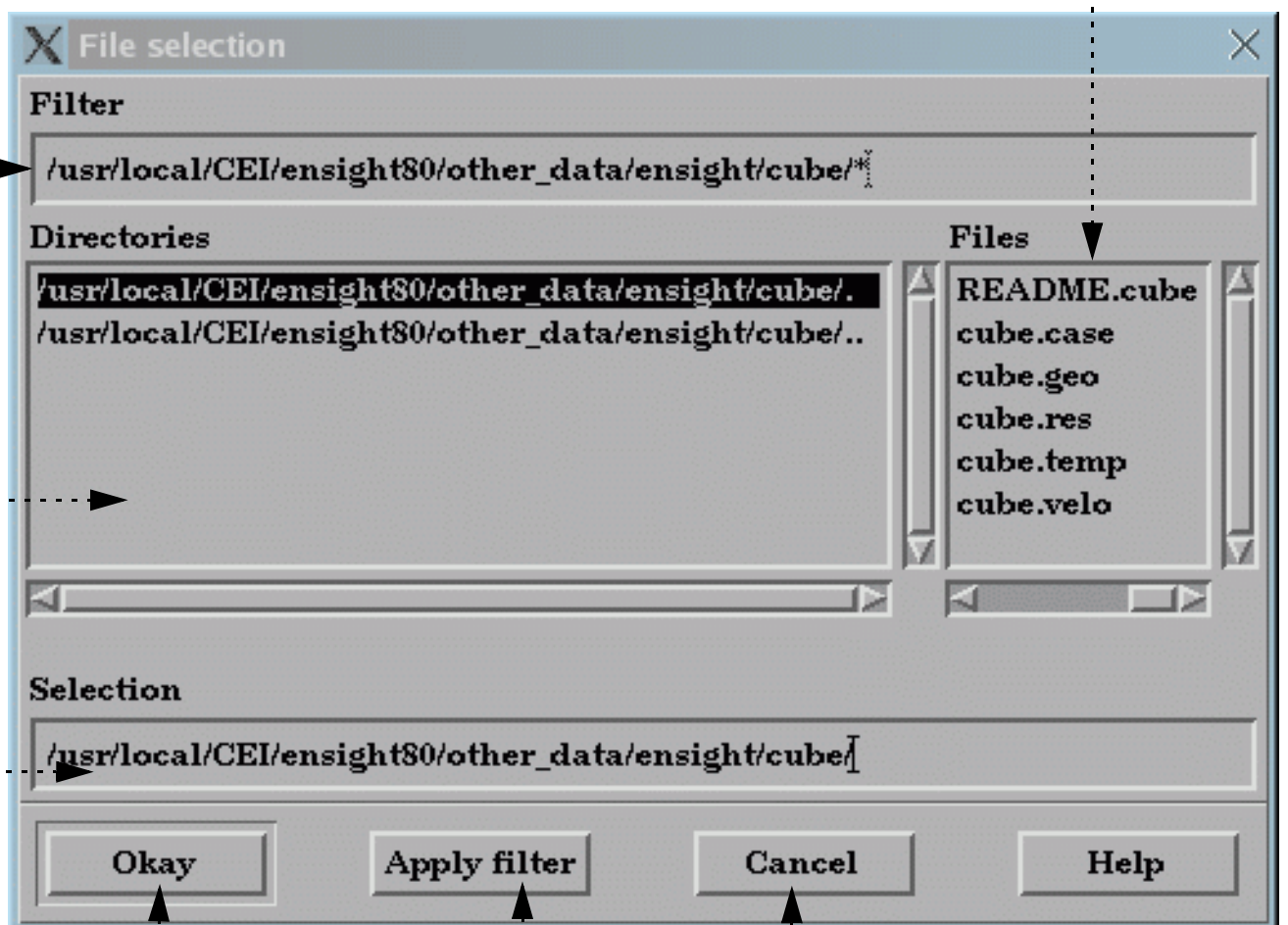

Click to accept the current Selection and close the dialog.

Click to apply the Filter after a change (you can also just press return after making a filter change).

Click to cancel the selection and close the dialog.



Wildcarding

The EnSight File Selection Filter field accepts a standard set of regular expression characters that let you restrict the display of files in the Files list to those that match the regular expression. This can be useful when trying to quickly locate specific files in directories that contain large numbers of items. By default, the Filter field displays the current directory with “*” appended. The “*” is a special character that matches a sequence of zero or more characters of any type. For example, “*.geo” will match all files in the current directory that end with “.geo”. This form of regular expression matching is essentially identical to that used by the UNIX shell programs (such as `cs`) to match file names when issuing commands.

You enter a wildcard by clicking the left mouse button in the Filter field and entering the desired text. When done, either press return or click the Apply Filter button. The Files list will then update to reflect the new filter.

The recognized regular expressions are:

Special Character	Description	Examples
*	Match any (zero or more) characters.	*.geo widget*.cmd
?	Match any single character.	gadget?.geo
[...]	Match any single character in the enclosed list(s) or range(s). A list is a string of characters. A range is two characters separated by a minus-sign (-), and includes all the characters in between in the ASCII collating sequence.	file[13579].rgb file[1-9].rgb
~	Matches your home directory. This is a special case: entering ~ (and pressing return) will set the current directory to your home directory and display all files in the Files list.	~ ~/*.geo
~user	Matches the home directory of <code>user</code> . This is a special case: entering ~ <code>user</code> (and pressing return) will set the current directory to the home directory of <code>user</code> and display all files in the Files list.	~joeuser ~joeuser/*.cmd

INTRODUCTION

Although most attributes of EnSight parts can be edited either through the appropriate Quick Interaction area or the Part Mode icon bar, full control is provided by the Feature Detail Editors for the various part types. Full control over variables (e.g. activation, color palette editing, and new variable calculation) is also provided through a Feature Detail Editor.

BASIC OPERATION

You can open the Feature Detail Editor by either selecting the appropriate item from the Edit > Part Feature Detail Editors menu or by double-clicking the appropriate part icon in the Feature Icon bar. All Feature Detail Editors (except the two dealing with Variables – see [below](#)) contain the same basic components:

Menu:
File (these items are only available for the Variables Feature Detail Editor – see below)

Edit
Select All: Select all parts listed in the dialog's parts list
Copy: Make a **copy** of the selected part(s)
Delete: **Delete** the selected part(s)
Immediate Modification: If on, all changes in the dialog have an immediate effect. If off, the Apply Changes button at the bottom must be clicked to apply your changes (good for batching several expensive changes).

View
Show Selected Part(s)...: Open the Selected Part(s) window to display only the selected parts.

List of variable/part icons; click to change to the desired Feature Detail Editor type.

Parts list of the current Feature Detail Editor type; lists only those parts of the current type. (For example, the contour Feature Detail Editor is shown and only the current contour parts are listed.)

Description of the currently selected part in the parts list. Click to type, make changes, and press return.

Creation Attributes section. This section (which is missing for Model parts) is unique to the Feature Detail Editor type and controls part-specific attributes (e.g. the isovalue of an isosurface).

The remaining sections (General, Node/Element/Line, and Displacement) control attributes common to all part types. See [How To Set Attributes](#) for more information.

Click to Close the Feature Detail Editor dialog.

Click to Create a new part based on the attributes as currently set and with parent part(s) as selected in the Main Parts list.

Click to change the parent part(s) of the selected part(s). The new parent part(s) must be selected in the Main Parts list.



Click to apply any changes you have made (only active when Immediate Modification is toggled off in the Feature Detail Editor Edit Menu).



The Feature Detail Editor for variables is different from the part Feature Detail Editors:

- To open the Feature Detail Editor for Variables either select **Edit > Variables Editor...** or double-click the **Color icon** in one of the modes (such as Part mode):



Menu:

File

Save Selected Palette(s)...: Write palettes for selected variables to a disk file

Save All Palettes...: Write palettes for all variables to a disk file

Restore Palette(s)...: Load palettes from a disk file

Edit

Select All: Select all parts listed in the dialog's parts list

Immediate Modification: If on, all changes in the dialog have an immediate effect. If off, the Apply Changes button at the bottom must be clicked to apply your changes (good for batching several expensive changes).

View

Show Selected Part(s)...: Not available in Variables Feature Detail Editor.

List of available variables. Click to select a variable.

Buttons to control variable activation/deactivation. See [How To Activate Variables](#) for more information.

Variable Summary and Palette section (Simple Interface is Shown). See [How To Edit Color Palettes](#) for more information.

Click to Close the Feature Detail Editor dialog.

Available variable	Type	Result
temperature	(* Gvn(N)	Scalar
velocity	(* Gvn(N)	Vector
Coordinates	(* Gvn(N)	Vector
Time	(* Gvn(N)	Scalar

Click to apply any changes you have made (only active when Immediate Modification is toggled off in the Feature Detail Editor Edit Menu).

The Feature Detail Editor for variable Calculator is also different from the part Feature Detail Editors:

1. To open the Feature Detail Editor for variable Calculator click the Calculator icon in the Feature Icon bar.....

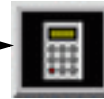

Variable Calculator section. See [Variable Creation](#) in the User Manual for more information.

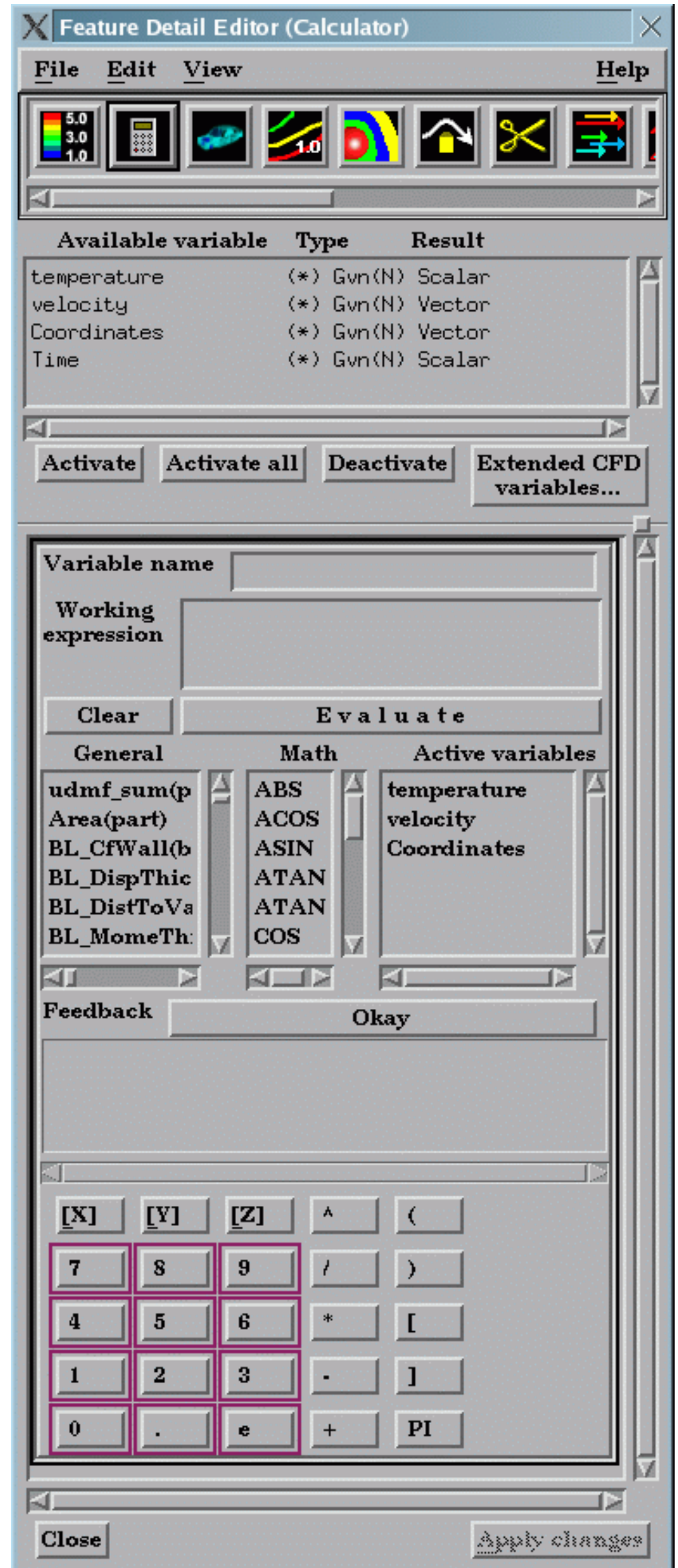

SEE ALSO

Most of the creation attributes for parts can also be set in the Quick Interaction area for the part type. See the How To article for the desired part type for more information.



Feature Icon Bar

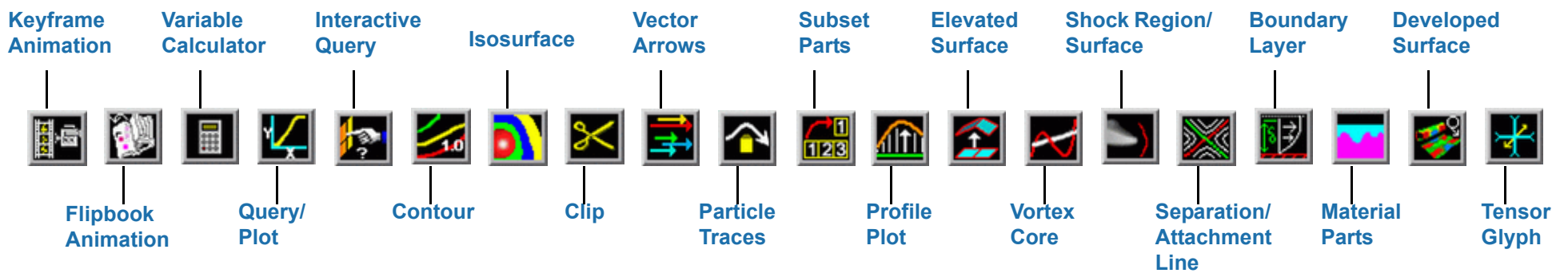

Transformation Control Icons

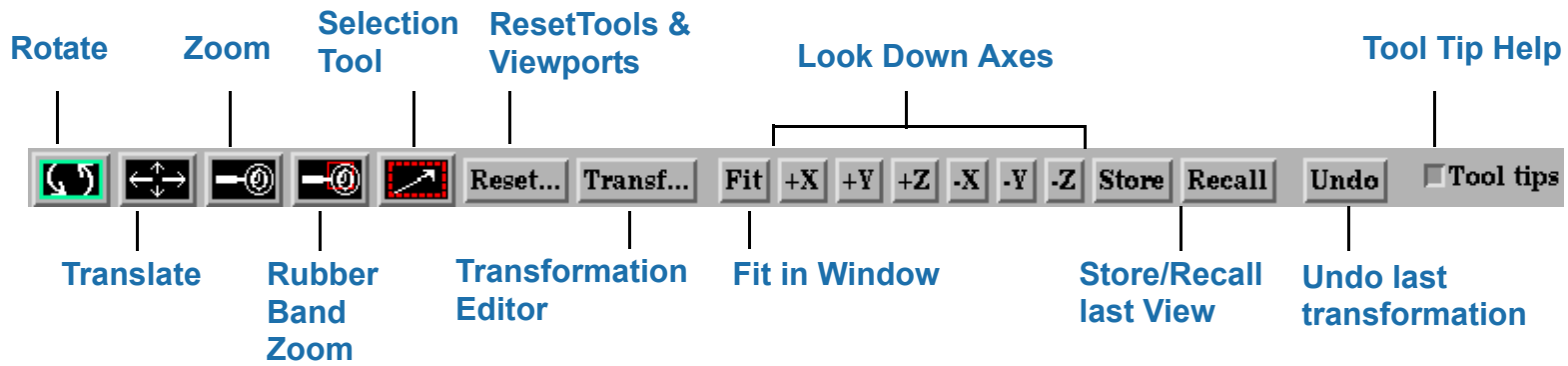

Part Mode

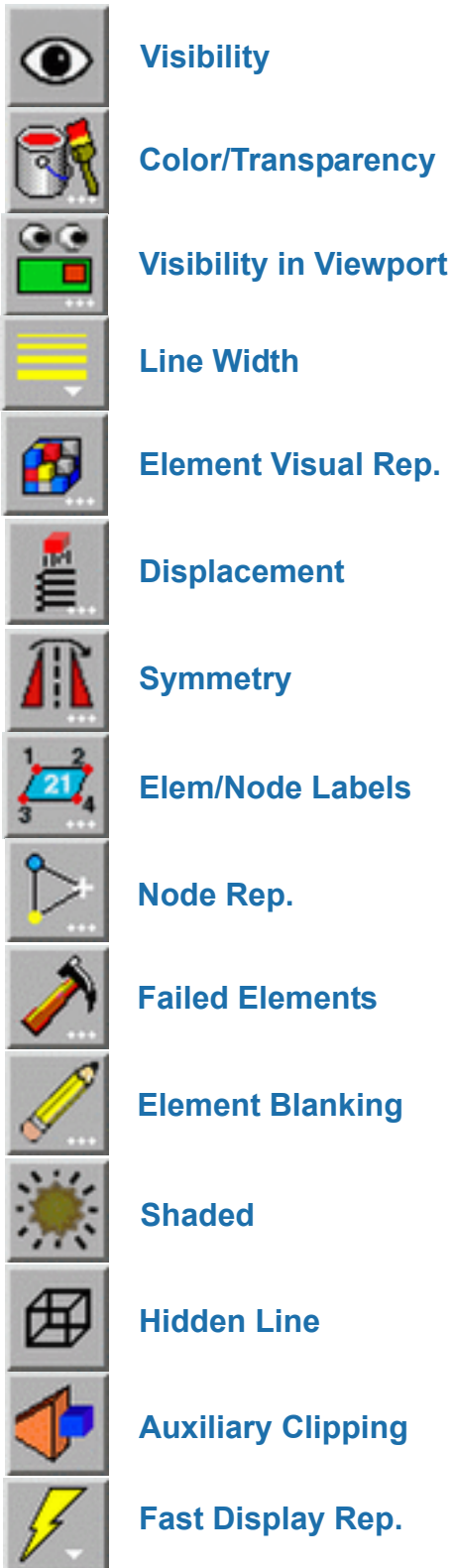

Global Toggle, Tool, and Other Desktop Icons



Vport Mode

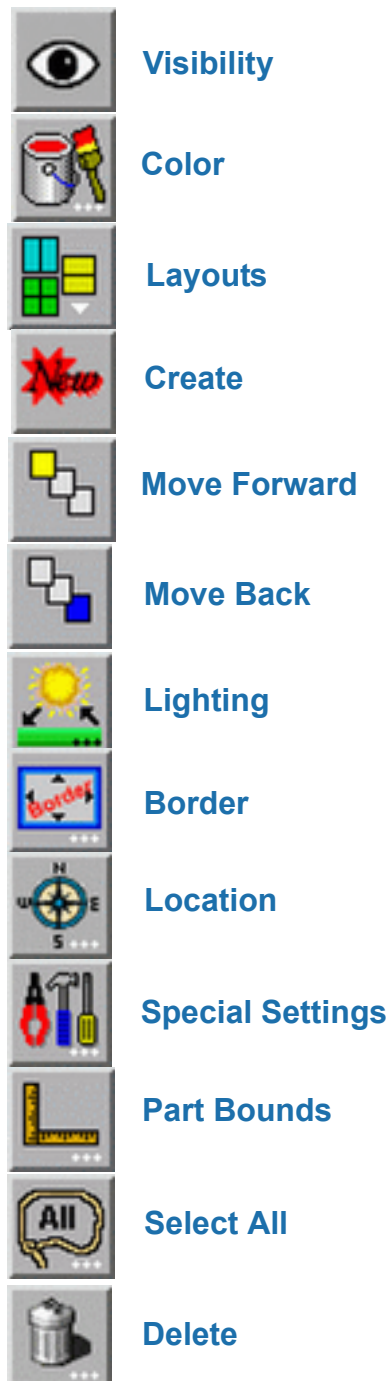

Frame Mode

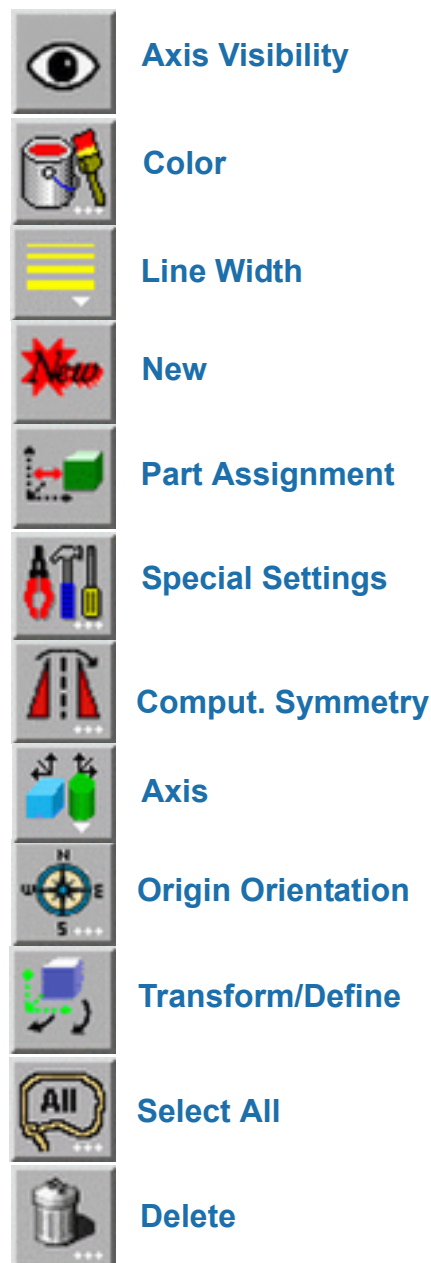

Annot Mode

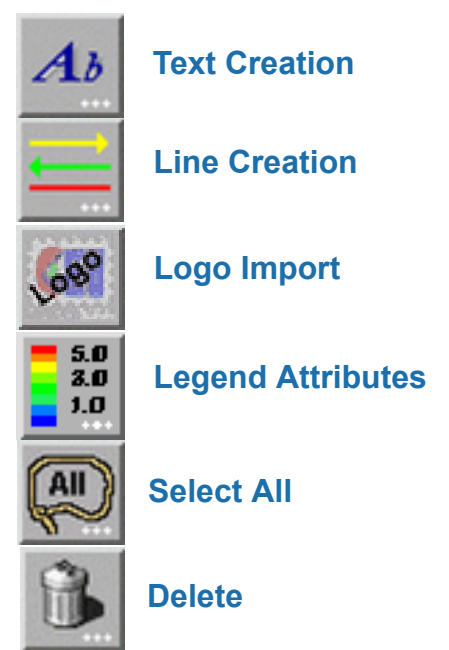

Plot Mode

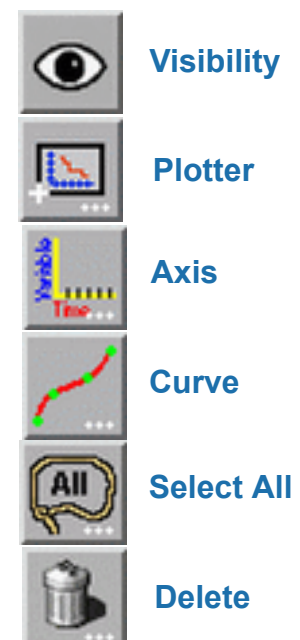



Index

A B C D E F G H I J K L M N O P Q R S T U V W X Y Z

A

- acrobat reader
- activating variables
- animation
 - flipbook
 - hints and tips
 - keyframe
 - mode shape
 - particle trace
 - recording to video
 - transient data
- annotation
 - color legend
 - line
 - logo
 - preferences
 - text
- archive
 - restore
 - save
- arrows, vector
- attachment line
- attributes
 - displacement
 - general
 - IJK Axis Display
 - node, element, line
 - part
- automatic connection
 - on Unix systems
 - on Windows systems
- auxiliary clipping
- AVI
 - compression
 - output
- B**
- background
 - color
 - image
- batch mode
- bitmap logo
- blanking
 - elements
- border representation
- boundary layer variables
- box
 - clip
 - tool
- C**
- calculator
- camera
 - look-at
 - look-from
 - projection
- case
 - adding
 - deleting
 - part, display by
 - reading
 - replacing
 - viewport visibility
- CEI RGB with depth
- CEI, Inc.
- center of transformation
 - picking
- CFD variables
- client/server overview
- clip
 - animation
 - auxiliary clipping
 - box
 - general quadric
 - grid
 - IJK
 - line
 - plane
 - quadric
 - revolution of 1D part
 - revolution tool
 - RTZ
 - XYZ
 - Z clipping
- collaboration
- color
 - background
 - default
 - legend
 - part
 - selector
 - variable palette
- command file
 - play
 - record
- command line options
 - client
 - ar
 - batch
 - bbox
 - bg
 - box_resolution
 - c
 - case
 - cm
 - collab_port
 - ctarget
 - ctx
 - custom
 - dconfig
 - delay_refresh
 - display_list
 - double_buffer
 - extcfd
 - externalcmdport
 - externalcmds
 - ff
 - fg
 - fn
 - font
 - frustrum_cull
 - gdbg
 - gl
 - glconfig
 - glsw
 - gold
 - h, -help, -Z
 - hc
 - helvetica
 - iconlbf
 - inputdbg
 - iwd
 - localhostname
 - maxoff
 - multi_sampling
 - multi_sampling_sw
 - nb
 - ni
 - no_delay_refresh
 - no_display_list
 - no_file_locking
 - no_frustrum_cull
 - no_multi_sampling
 - no_occlusion_test
 - no_prefs
 - no_start_screen
 - no_stencil_buff
 - norm_per_poly
 - norm_per_vert
 - num_samples
 - num_samples_st
 - occlusion_test
 - ogl
 - p
 - ports
 - prdist
 - range10
 - readerdbg
 - rsh
 - sc
 - scaleg
 - scalev
 - security
 - silent
 - single_buffer
 - slimtimeout
 - smallicons
 - smallscreen
 - sort_first
 - sort_last
 - sos
 - soshostname
 - standard
 - stderr
 - stdout
 - stencil_buff
 - swd
 - time
 - timeout
 - token_try_again
 - token_wait_for
 - token_wait_until
 - unmapdd
 - v

A B C D E F G H I J K L M N O P Q R S T U V W X Y Z

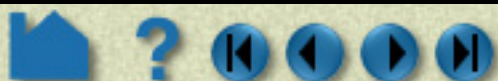



A B C D E F G H I J K L M N O P Q R S T U V W X Y Z

- version
- writerdbg
- X
- client examples
- preferences
- server
 - c
 - ctarget
 - ctries
 - ether
 - gdbg
 - h, -help
 - maxoff
 - pipe
 - ports
 - readerdbg
 - scaleg
 - scalev
 - security
 - sock
 - soshostname
 - time
 - writerdbg
- server examples
- sos
 - c
 - cports
 - ctarget
 - ctries
 - ether
 - gdbg
 - h, -help
 - maxoff
 - pipe
 - ports
 - readerdbg
 - rsh
 - scaleg
 - scalev
 - security
 - sock
 - soshostname
 - sports
 - time
 - writerdbg
- sos (server-of-servers) examples
- computation
 - setup for parallel
- computational symmetry
- cone
 - clip
 - tool
- connection
 - automatic
 - automatic on Unix systems
 - automatic on Windows systems
 - collaboration
- contacting CEI
- context
 - restore
 - save
- contour
- copy (part)
- created variables
- creating parts
- cursor tool
- customize
 - icon bars
 - mouse buttons
 - window positions
- cut (part)
- cylinder
 - clip
 - tool
- D**
- data
 - discrete
 - ens_checker
 - experimental
 - measured
 - preferences
 - reading
- dataset
 - information
 - querying
 - reading
- deactivating variables
- default color
- delete
 - frame
 - part
 - plotter
 - viewport
- Desktop
- developed surface
- discrete data
- displacements
- display remotely
- displaying stereo
- distance query
- documentation
 - acrobat reader
 - online use
 - printing
 - use of How To
- E**
- editing features
 - detail editor
- element
 - blanking
 - failed
 - labels
 - query
 - representation
- elevated surface
- email address
- ens_checker
- ensight8
 - start-up options
- ENSIGHT8_MAX_CTHREADS
- ENSIGHT8_MAX_SOSTHREADS
- ENSIGHT8_MAX_THREADS
- EnVideo output
- experimental data
- Extent Bounds
- extract (part)
- extracting
 - boundary layer variables
 - separation/attachment lines
 - shock surfaces/regions
 - vortex cores
- F**
- failed elements
 - removing
 - using with user-defined API
- fast display mode
- fax number
- feature angle representation
- feature detail editor
- file selection
- flipbook
 - animation
 - record
 - transient data animation
- frame
 - assigning parts to
 - attributes
 - creating
 - deleting
 - repositioning
 - selecting
 - transform reset
- full representation
- G**
- general quadric clip
- general user interface
 - preferences
- geometry
 - file
 - save in EnSight Gold format
 - save in VRML format
- grid clip
- group (part)
- H**
- hidden line overlay
- hidden surface drawing
- I**
- icon bar
 - customize
- icons
 - reference

A B C D E F G H I J K L M N O P Q R S T U V W X Y Z





A B C D E F G H I J K L M N O P Q R S T U V W X Y Z

- IJK
 - changing step refinement
 - clip
 - interactive plane sweep
 - query
- image output
 - preferences
- input devices
 - defining
- interactive
 - clipping
 - IJK
 - line
 - plane
 - quadric
 - RTZ
 - XYZ
 - isosurfaces
 - particle traces
 - probe preferences
 - query
- isosurface
 - animation
 - creation
 - interactive
- isovolume
 - creation
- J**
- JPEG output
- K**
- keyboard macros
- keyframe animation
 - Record
 - Run From/To
 - Save and Restore
 - Speed/Actions
 - Tips
 - Transient
 - Viewing Window
- L**
- labels
 - element
 - node
- legend, color
- light source
 - attributes
 - location
- lighting
 - attributes
 - model
 - static
- line
 - annotation
 - clip
 - tool
- logo annotation
- look-at
- look-from
- M**
- macros
- material part
- measured data
- merge (part)
- mode shapes
- Model Axis
- Model Extent Bounds
- mouse
 - buttons, customizing
 - preferences
- MPEG
 - out from flipbook
 - output options
- N**
- node
 - labels
 - query
- not loaded representation
- O**
- online documentation use
- orthographic projection
- output formats
 - AVI
 - EnVideo
 - JPEG
 - MPEG
 - PCL
 - PICT
 - Postscript
 - POVRAY
 - SGI RGB
 - TARGA
 - TIFF
- overview
 - client/server architecture
 - graphical user interface
 - parts concept
- P**
- palette
 - editing
 - preferences
- parallel computation
 - configuration
 - setup
- parallel rendering
 - setup
- part
 - attributes
 - box clip
 - clip plane
- clips
- color
- contour
- copy
- creation
- cut
- delete
- developed surface
- displacements
- element labels
- elevated surface
- extract
- group
- IJK clip
- introduction
- isosurface
- isovolume
- line clip
- material
- merge
- node labels
- particle trace
- preferences
- profile
- quadric clips
- query
- revolution of 1D part clip
- revolution tool clip
- RTZ clip
- save to disk file
- selection
- separation/attachment line
- shock surfaces/regions
- subset
- symmetry
 - computational
 - visual
- tensor glyphs
- transparency
- vector arrows
- vortex core
- XYZ clip
- Part Bounds Display
- particle traces
 - animation
 - creating
 - interactive
 - pathlines
 - record
 - streaklines
 - surface restricted
- parts concept
- PCL output
- performance
 - preferences
- periodicity
- perspective projection
- phone numbers

A B C D E F G H I J K L M N O P Q R S T U V W X Y Z





A B C D E F G H I J K L M N O P Q R S T U V W X Y Z

- pick
 - center of transformation
 - cursor tool
 - elements to blank
 - line tool
 - look-at point
 - part
 - plane tool
- PICT output
- plane clip
- Plane tool
- plotter
 - anatomy
 - attributes
 - create
 - delete
 - moving/resizing
 - preferences
 - selecting
 - visibility
- point
 - query
- PostScript output
- POVRAY
 - output
- preferences
 - annotation
 - color palettes
 - command line
 - data
 - general user interface
 - icon bar
 - image saving/printing
 - interactive probe
 - macros
 - mouse and keyboard
 - part
 - performance
 - plotter
 - query
 - user defined input
 - variables
 - view
 - window positions
- printing
 - documentation
 - images
- probe query
- profile plot
- Q**
- quadric clip
- query
 - dataset
 - element
 - IJK
 - interactive
 - node
- over distance
- part
- point
- preferences
- R**
- reading
 - data (introduction)
 - ens_checker
 - ensight_reader_extension.map file
 - File->Data(reader)...
 - File->Open...
 - new data without quitting
 - Quick method
 - server of servers
 - transient data
 - Two-Step method
 - user defined data reader
- reference
 - icons
- rendering
 - setup for parallel
- representation
 - border
 - bounding box
 - feature angle
 - full
 - non visual
- reset
 - frame transform
 - transformations
- restart
 - session (archive)
 - without quitting client
- restore
 - context
 - keyframe animation
 - session (archive)
 - viewing parameters
- result file
- revolution of 1D part clip
- revolution tool
 - clip
- RGB image output
- rotate
- RTZ
 - clip
- S**
- save
 - command file
 - context
 - geometry
 - image
 - keyframe animation
 - POVRAY
 - preferences
 - scenario
- session (archive)
- viewing parameters
- scale
- scenario
 - save
- selecting
 - colors
 - elements to blank
 - files
 - parts
- selection tool
 - element blanking
 - for subset parts
 - zooming
- separation line
- Server of Servers
 - using
- setup for parallel computation
- setup for parallel rendering
- shaded surface drawing
- shock
 - surface/region
- Silicon Graphics RGB output
- solution time
 - recording animation
- sphere
 - clip
 - tool
- starting
 - automatically
 - options
- static lighting
- stereo display
- subset parts
 - pick elements
 - selection tool
- surface of revolution tool
- surfaces, developed
- symmetry
 - computational
 - visual
- T**
- TARGA output
- tensor glyph parts
- text annotation
- threads
 - ENSIGHT8_MAX_CTHREADS
 - ENSIGHT8_MAX_SOSTHREADS
 - ENSIGHT8_MAX_THREADS
- TIFF output
- time
 - stepping through
- tools
 - box
 - cone
 - cursor

A B C D E F G H I J K L M N O P Q R S T U V W X Y Z





A B C D E F G H I J K L M N O P Q R S T U V W X Y Z

cylinder
line
Plane
resetting
selection
sphere
surface of revolution

traces
animation
creating
interactive
pathlines
streaklines
surface restricted

tracking
tracking in viewports

transformations
frames
resetting
rotate
scale
translate
zoom

transient data
animation
reading
setting current time
stepping through

translate

transparency

U

unrolling surfaces
user defined
data reader
input devices
input preferences

Using Server of Servers
SOS

V

variable
activation
and cases
boundary layer
calculator
color palette
common CFD
deactivation
preferences

vector arrows
density

view
preferences

viewport
2D or 3D
attributes
background image

camera projection
case visibility
color
creating
deleting
lighting attributes
Part Bounds Display
part display
repositioning
resetting
saving viewing parameters
standard layouts
tracking

viewport tracking
Virtual Reality setup
visual representation
vortex cores
VR setup
VRML

W

window positions, customizing
working variable (default color)

X

XYZ
clip
interactive plane sweep

Z

Z clipping
zoom
rubberband
to region
using selection tool

A B C D E F G H I J K L M N O P Q R S T U V W X Y Z

